

# PRESS BRAKE TOOLS FACTORY CATALOGUE





SINCE 1986

Dal 1986 Gimec è tra le aziende più qualificate nella costruzione di utensili ed attrezzature per la lavorazione della lamiera.

In particolare siamo specializzati nella fornitura di utensili per presse piegatrici e lame per cesoia. L'analisi metodica di tutti i materiali impiegati, il controllo accurato del prodotto durante le varie fasi produttive e la continua ricerca innovativa, contribuiscono ad accrescere l'alto livello tecnologico raggiunto dalla Gimec in tale settore.

Siamo un'azienda compatta ed agile, che opera quotidianamente con passione ed entusiasmo, caratteristiche che da sempre ci contraddistinguono sul mercato.

In un'economia sempre più competitiva, cerchiamo di fornire il miglior servizio, con prodotti di alta qualità, progettando e proponendo soluzioni efficaci e funzionali.

Since 1986 Gimec is among the leading companies in the manufacturing of tools and equipment for sheet metal working.

In particular, we are specialized in providing tools for press brake and shear blades.

The methodical analysis of all materials used, the careful monitoring of the product during the various stages of production and continued innovative research, help us to increase the high technological level reached in this area.

We are a compact and agile company, which daily works with passion and enthusiasm, characteristics that have always distinguished us in the market.

In a more and more competitive economy, we try to provide the best service with high quality products, designing and proposing effective and useful solutions.

**45°37'05.7"N 9°16'00.6"E**  
**Google plus code J798+8P**



## UTENSILI SUPERIORI - UPPER TOOLS

tipo <b>Europa</b> <sup>®</sup> style	pag. 04	<b>serie US</b> <sup>®</sup>
tipo <b>Japan</b> <sup>®</sup> style	pag. 26	<b>serie USJ</b> <sup>®</sup>
tipo <b>Trumpf Wila</b> <sup>®</sup> style	pag. 44	<b>serie UST</b> <sup>®</sup>
tipo <b>Beyeler Bystronic</b> <sup>®</sup> style	pag. 62	<b>serie USB</b> <sup>®</sup>
tipo <b>LVD</b> <sup>®</sup> style	pag. 70	<b>serie USL</b> <sup>®</sup>
tipo <b>COLGAR</b> <sup>®</sup> style	pag. 84	<b>serie USC</b> <sup>®</sup>
tipo <b>HACO</b> <sup>®</sup> style	pag. 82	<b>serie USH</b> <sup>®</sup>

## UTENSILI INFERIORI - LOWER TOOLS

tipo <b>Europa</b> <sup>®</sup> style	pag. 28	<b>serie 60</b> <sup>®</sup>
tipo <b>Trumpf Wila</b> <sup>®</sup> style	pag. 60	<b>serie 13 UST</b> <sup>®</sup>
tipo <b>Beyeler Bystronic</b> <sup>®</sup> style	pag. 68	<b>serie 13 USB</b> <sup>®</sup>
tipo <b>LVD</b> <sup>®</sup> style	pag. 80	<b>serie 12,7 USL</b> <sup>®</sup>
tipo <b>ROLLA-V</b> <sup>®</sup> style	pag. 86	<b>serie ROLLA-V</b> <sup>®</sup>
tipo <b>HACO</b> <sup>®</sup> style	pag. 82	<b>serie USH</b> <sup>®</sup>

## UTENSILI - TOOLS

STAMPI PER PRESSE PIEGATRICI - PRESS BRAKE TOOLS	pag. 92	<b>STAMPI</b>
TAVOLE PIEGASCHIACCIA - FLATTENING TABLES	pag.102	<b>FLATTENING</b>
PROFILI DOOR FRAMES - DOOR FRAME PROFILES	pag.104	<b>DOOR FRAME</b>
LATTONIERE - TINSMITH	pag.105	<b>LATTONERIA</b>
SISTEMI DI CENTINATURA - CROWNING SYSTEMS	pag.106	<b>TABLUS</b>
PORTA UTENSILI - TOOLS HOLDER	pag.110	<b>PORTA UT</b>
LAME PER CESCOIA - SHEAR BLADES	pag.114	<b>LAME</b>
ATTREZZATURE - FIXTURES	pag.116	<b>ATTREZZATURE</b>

## GET IN TOUCH



GIMECsr channel



WhatsApp Business

+39.335.6028050 *Roberto*  
 +39.366.1736342 *Pierpaolo*  
 +39.333.9040177 *Franco*



gimec\_press\_brake\_tools  
 gimec\_press\_brake\_tools\_videos  
 gimec\_press\_brake\_tools\_images

NON ESITARE A CONTATTARCI - PROFESSIONALITA' E COMPETENZA SONO I NOSTRI PUNTI DI FORZA  
 DON'T HESITATE TO CONTACT US PROFESSIONALISM AND COMPETENCE ARE OUR STRENGTH POINTS

**US 110/90° R0,8**

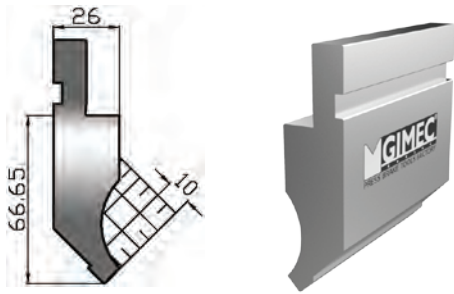

altezza height mm	angolo degree	raggio radius	acciaio steel	max kN/mt
66,65	90°	0,8	C45 T HRC 52÷58	1000
lunghezze - lengths			mm 835 - 415 - fraz 805 (1)	

**US 126/90° R0,6**

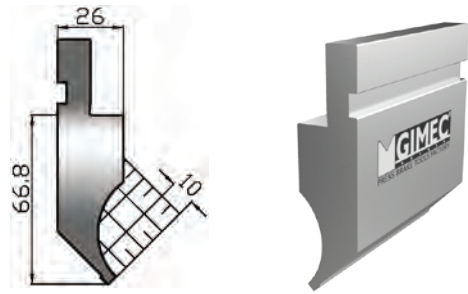

altezza height mm	angolo degree	raggio radius	acciaio steel	max kN/mt
66,8	90°	0,6	42CM4 T HRC 52÷58	350
lunghezze - lengths			mm 835 - 415 - fraz 805 (1)	

**US 117/90° R0,6**

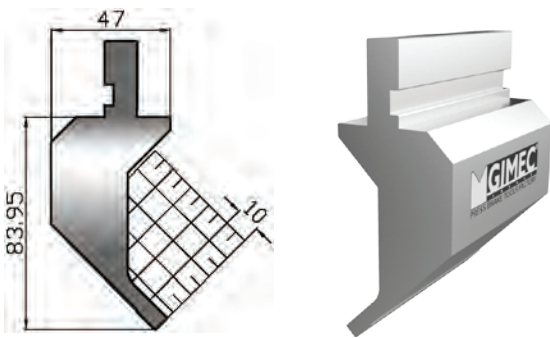

altezza height mm	angolo degree	raggio radius	acciaio steel	max kN/mt
83,95	90°	0,6	42CM4 T HRC 52÷58	300
lunghezze - lengths			mm 835 - 415 - fraz 805 (1)	

**US 115/90° R0,8**

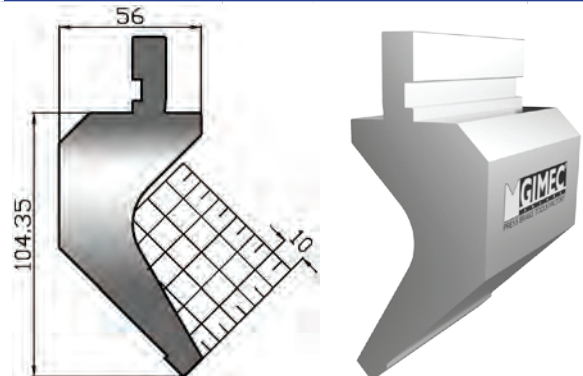

altezza height mm	angolo degree	raggio radius	acciaio steel	max kN/mt
104,35	90°	0,8	C45 T HRC 52÷58	500
lunghezze - lengths			mm 835 - 415 - fraz 805 (1)	

**PIEGATURA IN ARIA**

**PIEGATURA A FONDO MATRICE o CONIATURA**



**AIR BENDING**

**BENDING ON LOWER TOOL BOTTOM or COINING**

**US 110/88° R0,8**

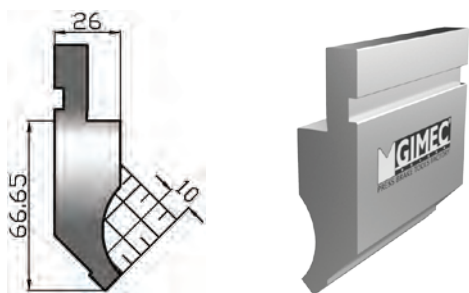

**US 110/88° R3,0**

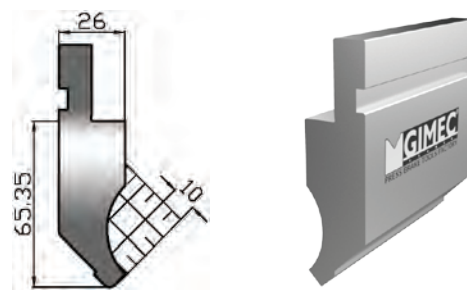

altezza height mm	angolo degree	raggio radius	acciaio steel	max kN/mt
66,65	88°	0,8	C45 T HRC 52÷58	1000
lunghezze - lengths		mm 835 - 415 - fraz 805 (1)		

altezza height mm	angolo degree	raggio radius	acciaio steel	max kN/mt
65,35	88°	3,0	C45 T HRC 52÷58	1000
lunghezze - lengths		mm 835 - 415 - fraz 805 (1)		

**US 126/88° R0,6**

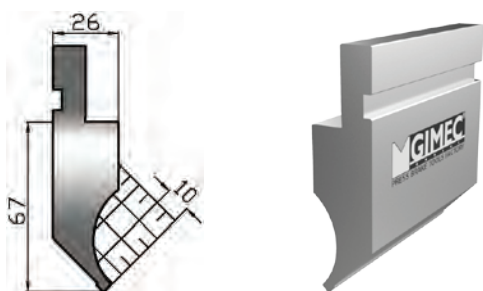

**US 125/88° R0,8**

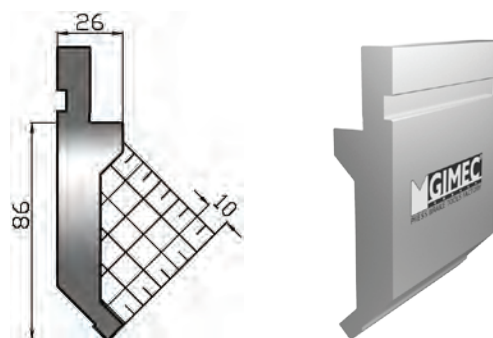

altezza height mm	angolo degree	raggio radius	acciaio steel	max kN/mt
67,0	88°	0,6	42CM4 T HRC 52÷58	350
lunghezze - lengths		mm 835 - 415 - fraz 805 (1)		

altezza height mm	angolo degree	raggio radius	acciaio steel	max kN/mt
86,0	88°	0,8	C45 T HRC 52÷58	500
lunghezze - lengths		mm 835 - 415 - fraz 805 (1)		

**US 143/88° R0,6**

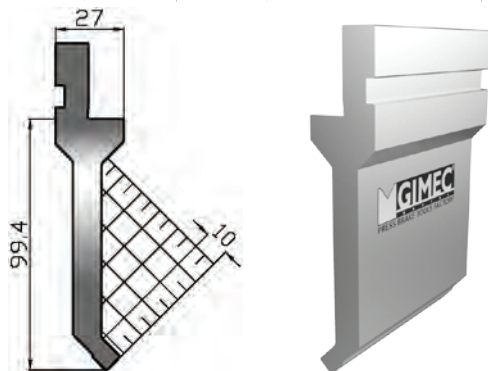

**US 120/88° R0,8**

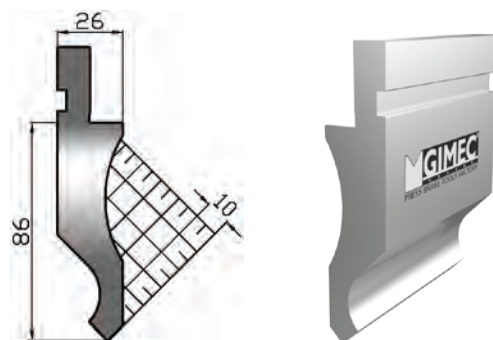

altezza height mm	angolo degree	raggio radius	acciaio steel	max kN/mt
99,4	88°	0,6	C45 T HRC 52÷58	500
lunghezze - lengths		mm 835 - 415 - fraz 805 (1)		

altezza height mm	angolo degree	raggio radius	acciaio steel	max kN/mt
86,0	88°	0,8	C45 T HRC 52÷58	500
lunghezze - lengths		mm 835 - 415 - fraz 805 (1)		

serie US®

STANDARD TOOLS

**US 147/88° R0,25**

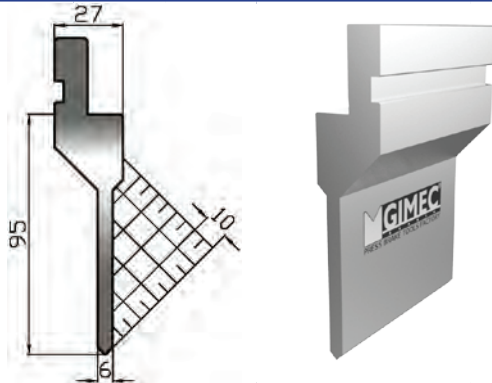

altezza height mm	angolo degree	raggio radius	acciaio steel	max kN/mt
95,0	88°	0,25	42CM4 T HRC 52÷58	500
lunghezze - lengths			mm 835 - 415 - fraz 805 (1)	

**US 117/88° R0,6**

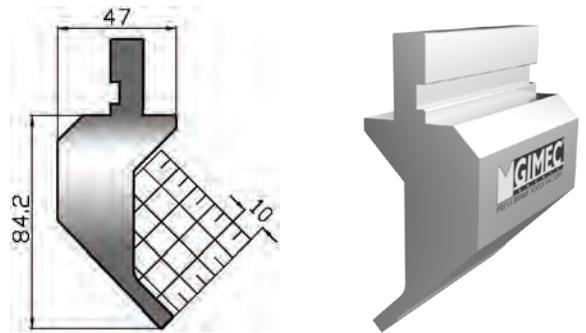

altezza height mm	angolo degree	raggio radius	acciaio steel	max kN/mt
84,2	88°	0,6	42CM4 T HRC 52÷58	300
lunghezze - lengths			mm 835 - 415 - fraz 805 (1)	

**US 114/88° R0,8**

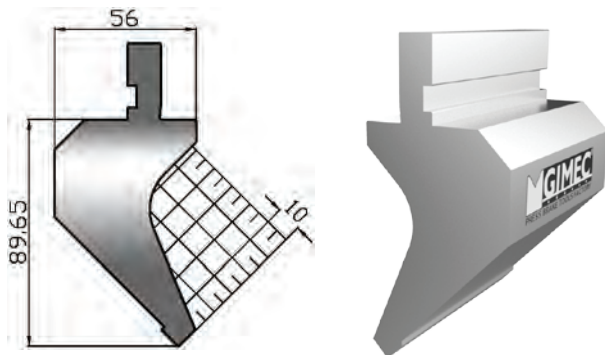

altezza height mm	angolo degree	raggio radius	acciaio steel	max kN/mt
89,65	88°	0,8	C45 T HRC 52÷58	600
lunghezze - lengths			mm 835 - 415 - fraz 805 (1)	

**US 114/88° R3,0**

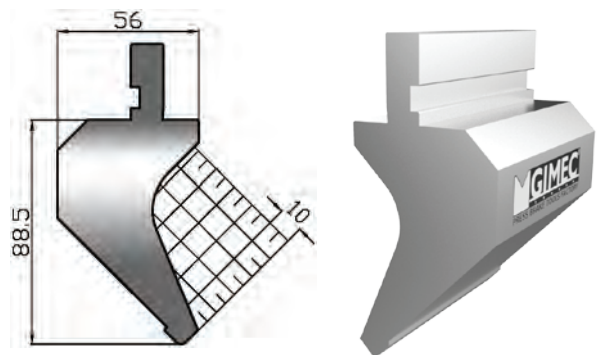

altezza height mm	angolo degree	raggio radius	acciaio steel	max kN/mt
88,5	88°	3,0	C45 T HRC 52÷58	600
lunghezze - lengths			mm 835 - 415 - fraz 805 (1)	

**US 115/88° R0,8**

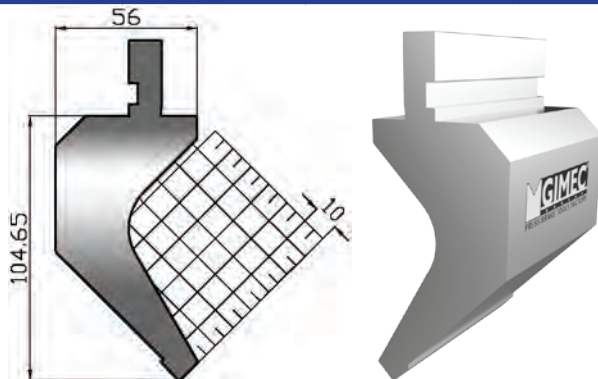

altezza height mm	angolo degree	raggio radius	acciaio steel	max kN/mt
104,65	88°	0,8	C45 T HRC 52÷58	500
lunghezze - lengths			mm 835 - 415 - fraz 805 (1)	

**US 115/88° R3,0**

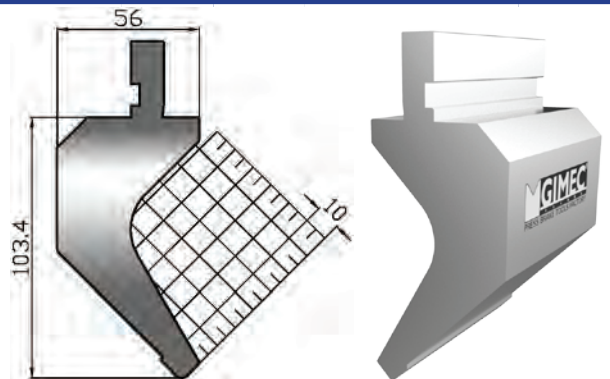

altezza height mm	angolo degree	raggio radius	acciaio steel	max kN/mt
103,4	88°	3,0	C45 T HRC 52÷58	500
lunghezze - lengths			mm 835 - 415 - fraz 805 (1)	

serie US®

STANDARD TOOLS

**US 144/88° R0,8**

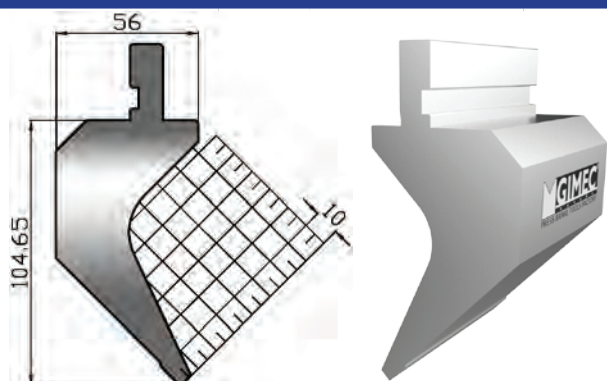

altezza height mm	angolo degree	raggio radius	acciaio steel	max kN/mt
104,65	88°	0,8	C45 T HRC 52÷58	450
lunghezze - lengths		mm 835 - 415 - fraz 805 (1)		

**US 158/88° R0,8**

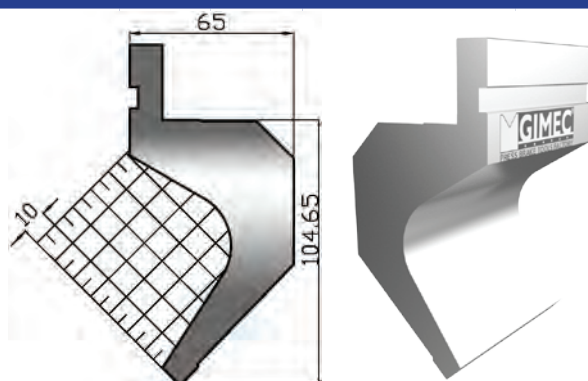

altezza height mm	angolo degree	raggio radius	acciaio steel	max kN/mt
104,65	88°	0,8	C45 T HRC 52÷58	450
lunghezze - lengths		mm 835 - 415 - fraz 805 (1)		

**US 152/88° R0,8**

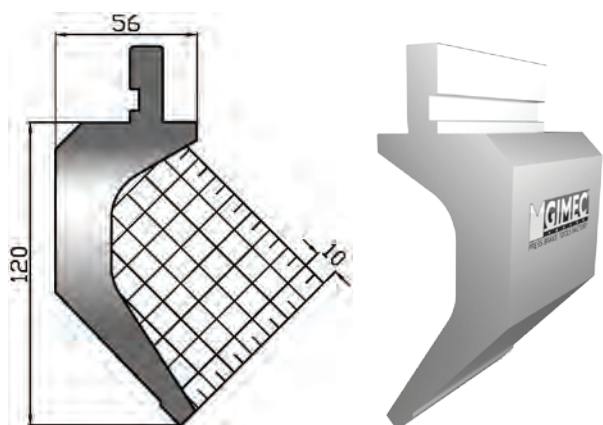

altezza height mm	angolo degree	raggio radius	acciaio steel	max kN/mt
120,0	88°	0,8	42CM4 T HRC 52÷58	500
lunghezze - lengths		mm 835 - 415 - fraz 805 (1)		



serie US®

STANDARD TOOLS

**US 110/85° R0,8**

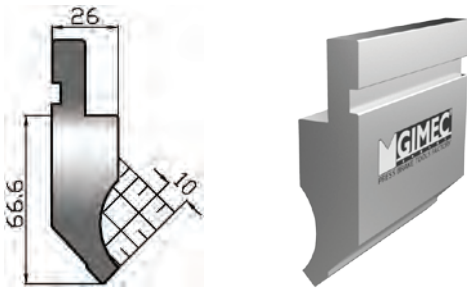

altezza height mm	angolo degree	raggio radius	acciaio steel	max kN/mt
66,6	85°	0,8	C45 T HRC 52÷58	1000
lunghezze - lengths			mm 835 - 415 - fraz 805 (1)	

**US 110/85° R0,8 h105**

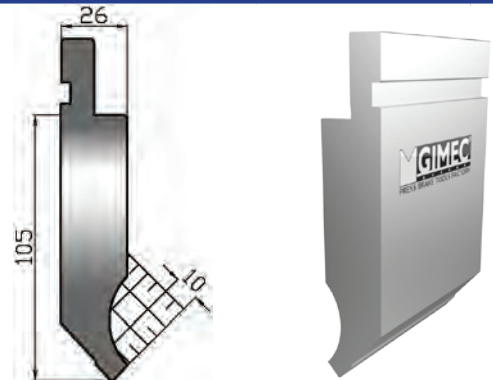

altezza height mm	angolo degree	raggio radius	acciaio steel	max kN/mt
105,0	85°	0,8	C45 T HRC 52÷58	1000
lunghezze - lengths			mm 835 - 415 - fraz 805 (1)	

**US 143/85° R0,25**

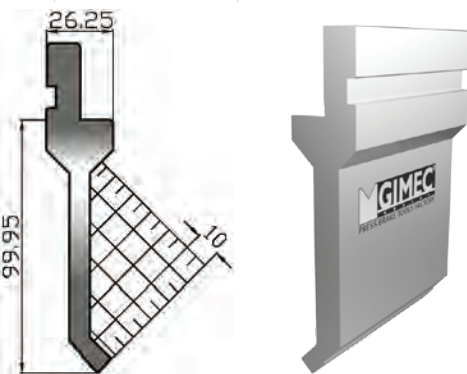

altezza height mm	angolo degree	raggio radius	acciaio steel	max kN/mt
99,95	85°	0,25	42CM4 T HRC 52÷58	350
lunghezze - lengths			mm 835 - 415 - fraz 805 (1)	

**US 142/85° R0,8**

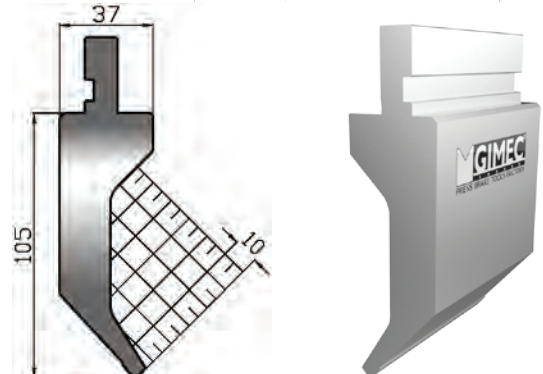

altezza height mm	angolo degree	raggio radius	acciaio steel	max kN/mt
105,0	85°	0,8	42CM4 T HRC 52÷58	600
lunghezze - lengths			mm 835 - 415 - fraz 805 (1)	

**US 115/85° R0,8**

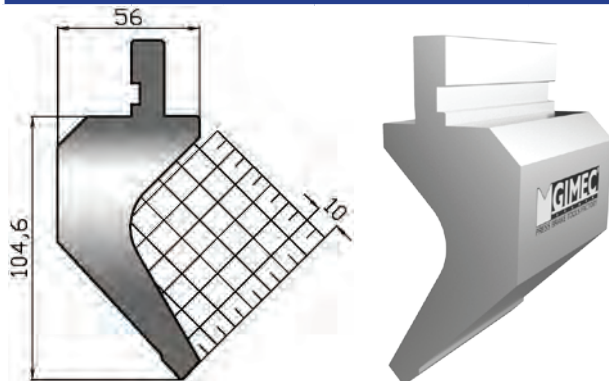

altezza height mm	angolo degree	raggio radius	acciaio steel	max kN/mt
104,6	85°	0,8	C45 T HRC 52÷58	500
lunghezze - lengths			mm 835 - 415 - fraz 805 (1)	

**US 129/85° R0,8**

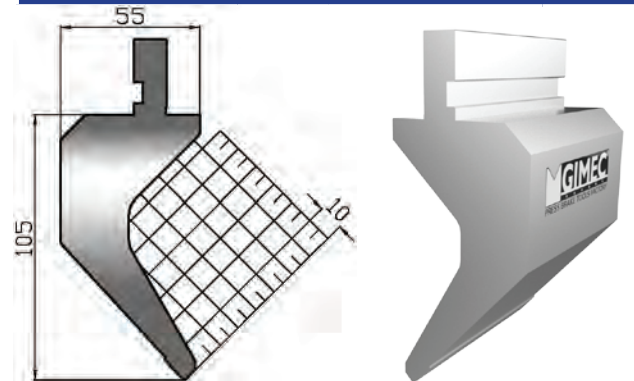

altezza height mm	angolo degree	raggio radius	acciaio steel	max kN/mt
105,0	85°	0,8	42CM4 T HRC 52÷58	1000
lunghezze - lengths			mm 835 - 415 - fraz 805 (1)	

serie US®

STANDARD TOOLS



**US 141/85° R0,8**

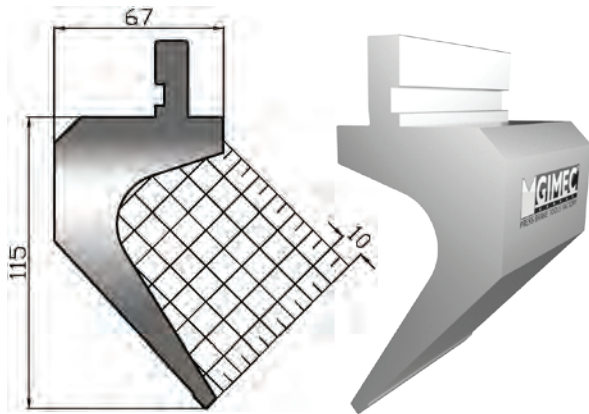

altezza height mm	angolo degree	raggio radius	acciaio steel	max kN/mt
115,0	85°	0,8	42CM4 T HRC 52÷58	700
lunghezze - lengths		mm 835 - 415 - fraz 805 (1)		

**US 127/85° R0,8**

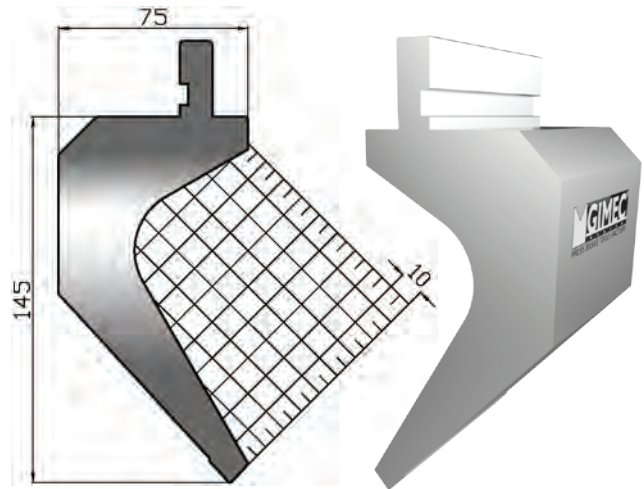

altezza height mm	angolo degree	raggio radius	acciaio steel	max kN/mt
145,0	85°	0,8	C45 T HRC 52÷58	500
lunghezze - lengths		mm 835 - 415 - fraz 805 (1)		

**US 145/85° R2,0**

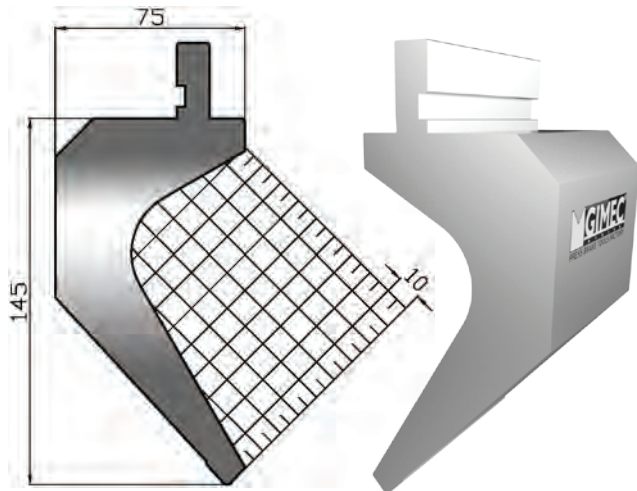

altezza height mm	angolo degree	raggio radius	acciaio steel	max kN/mt
145,0	85°	2,0	42CM4 T HRC 52÷58	900
lunghezze - lengths		mm 835 - 415 - fraz 805 (1)		

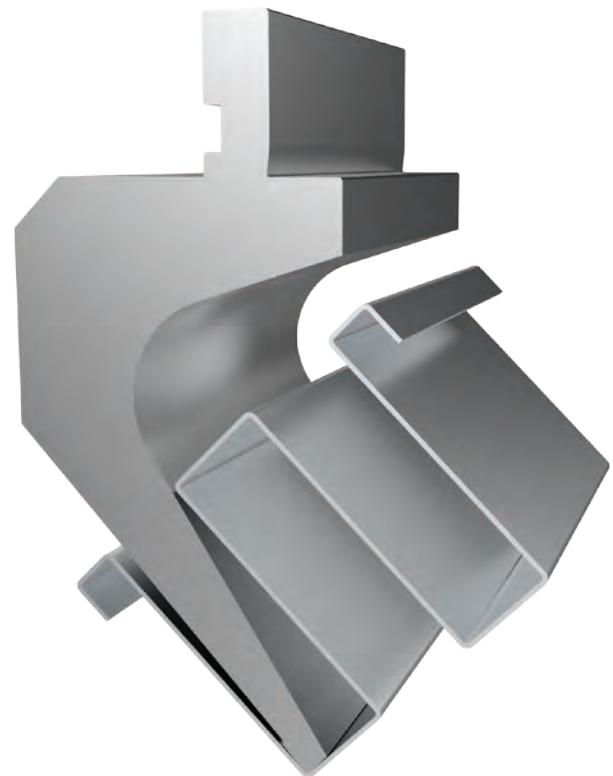

serie US®

STANDARD TOOLS

**US 175/85° R0,8**

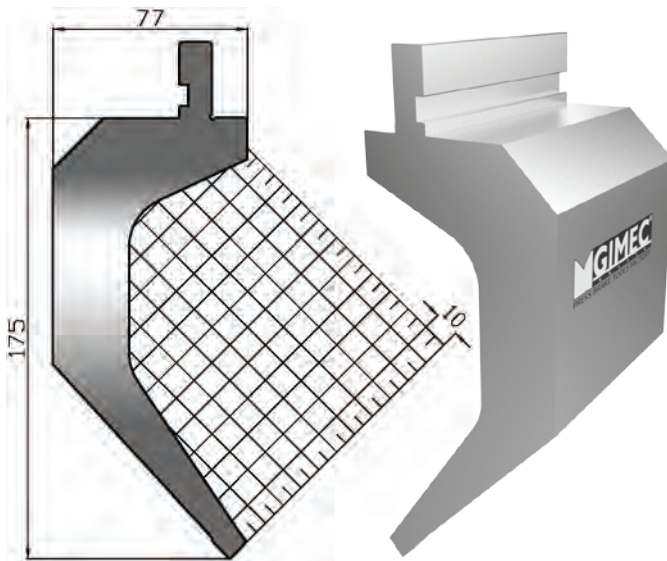

**US 175/85° R2,0**

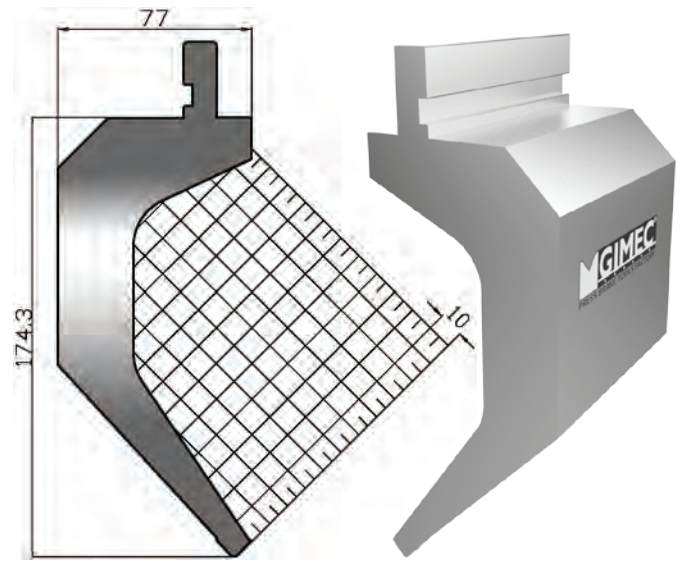

altezza height mm	angolo degree	raggio radius	acciaio steel	max kN/mt
175,0	85°	0,8	42CM4 T HRC 52÷58	700
lunghezze - lengths			mm 525-frazA495-B500 (2)	

altezza height mm	angolo degree	raggio radius	acciaio steel	max kN/mt
174,3	85°	2,0	42CM4 T HRC 52÷58	700
lunghezze - lengths			mm 525-frazA495-B500 (2)	

**US 153/85° R0,8**

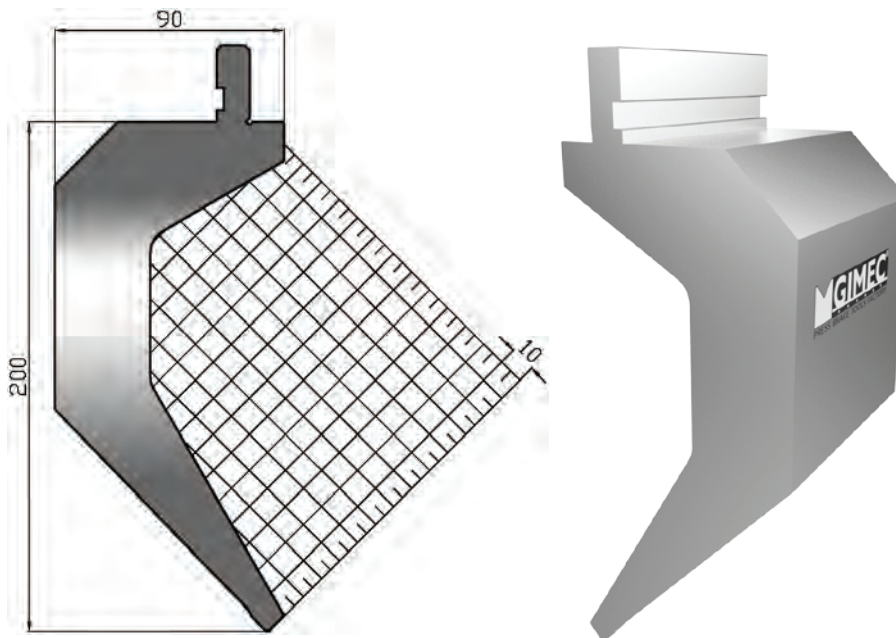

altezza height mm	angolo degree	raggio radius	acciaio steel	max kN/mt
200,0	85°	0,8	C45 T HRC 52÷58	850
lunghezze - lengths			mm 415 - fraz 805 (1)	

serie US®

STANDARD TOOLS

**US 146/85° R1,25**

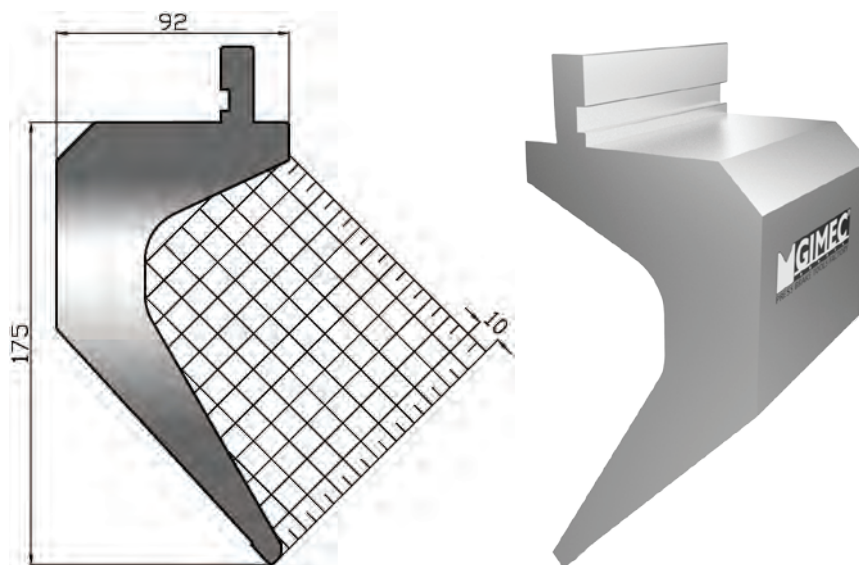

altezza height mm	angolo degree	raggio radius	acciaio steel	max kN/mt
175,0	85°	1,25	42CM4 T HRC 52+58	900
lunghezze - lengths			mm 835 - 415 - fraz 805 (1)	

**US 156/85° R1,5**

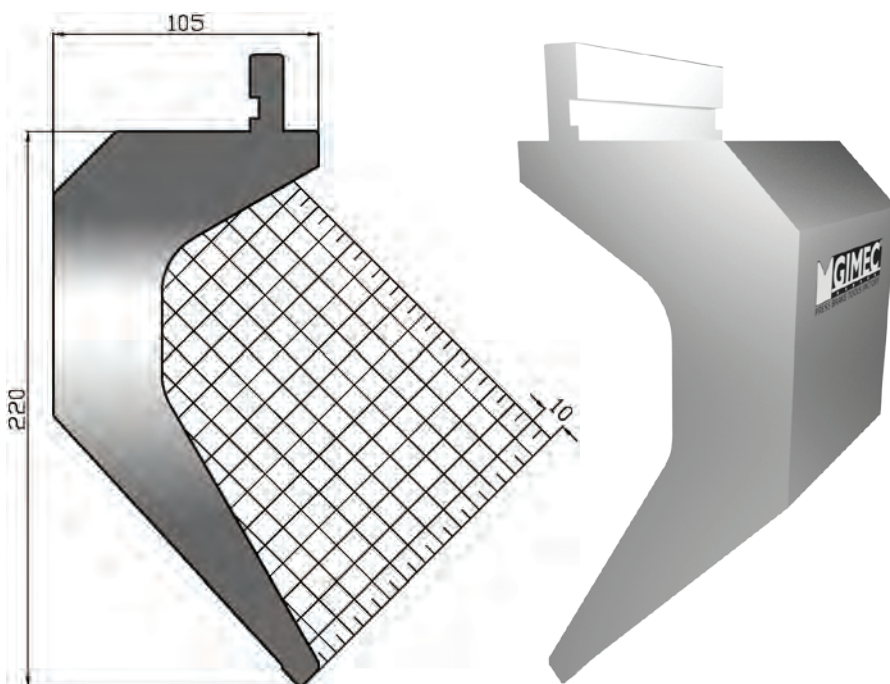

altezza height mm	angolo degree	raggio radius	acciaio steel	max kN/mt
220,0	85°	1,5	42CM4 T HRC 52+58	850
lunghezze - lengths			mm 415 - fraz 805 (1)	

**US 170/70° R0,8**

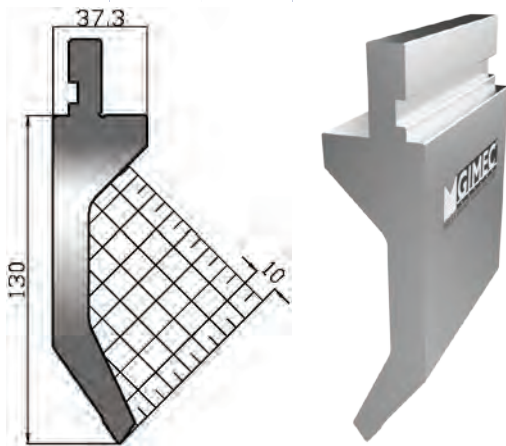

altezza height mm	angolo degree	raggio radius	acciaio steel	max kN/mt
130,0	70°	0,8	42CM4 T HRC 52-58	450
lunghezze - lengths			mm 835 - 415 - fraz 805 (1)	

**US 110/75° R0,8**

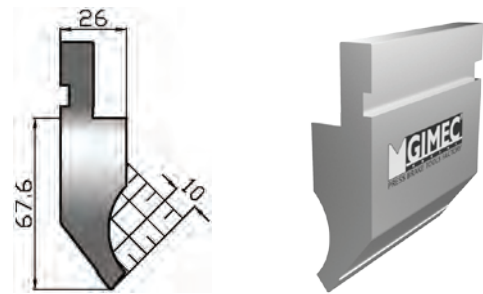

altezza height mm	angolo degree	raggio radius	acciaio steel	max kN/mt
67,6	75°	0,8	42CM4 T HRC 52-58	1000
lunghezze - lengths			mm 835 - 415 - fraz 805 (1)	

**US 170/70° R3,0**

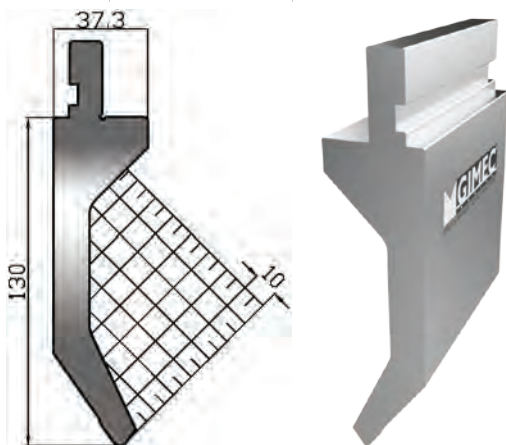

altezza height mm	angolo degree	raggio radius	acciaio steel	max kN/mt
130,0	70°	3,0	42CM4 T HRC 52-58	450
lunghezze - lengths			mm 835 - 415 - fraz 805 (1)	

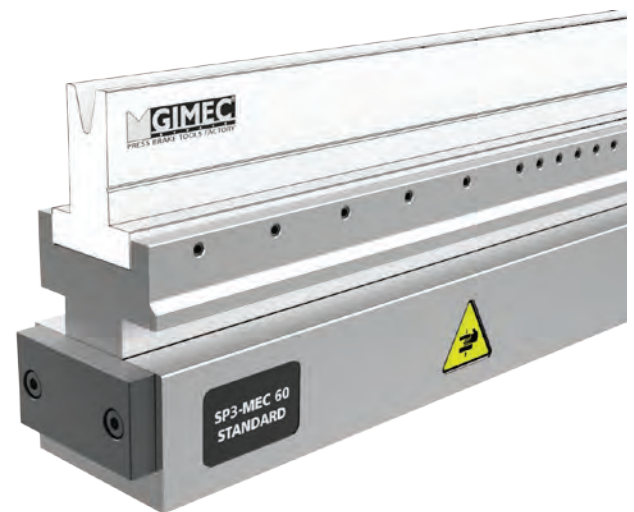

serie US®

STANDARD TOOLS

trovali a pagina 102 e 103  
find them on page 102 and 103

**US 124/60° R0,8**

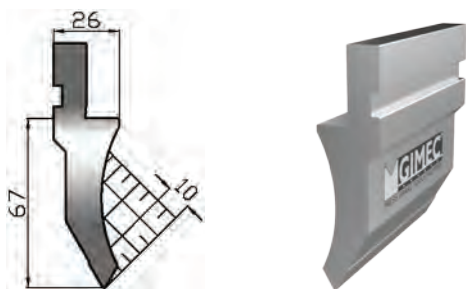

**US 124/60° R2,0**

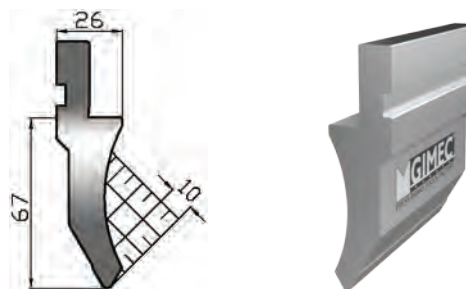

altezza height mm	angolo degree	raggio radius	acciaio steel	max kN/mt
67,0	60°	0,8	C45 T HRC 52-58	800
lunghezze - lengths		mm 835 - 415 - fraz 805 (1)		

altezza height mm	angolo degree	raggio radius	acciaio steel	max kN/mt
67,0	60°	2,0	C45 T HRC 52-58	800
lunghezze - lengths		mm 835 - 415 - fraz 805 (1)		

**US 148/60° R0,8**

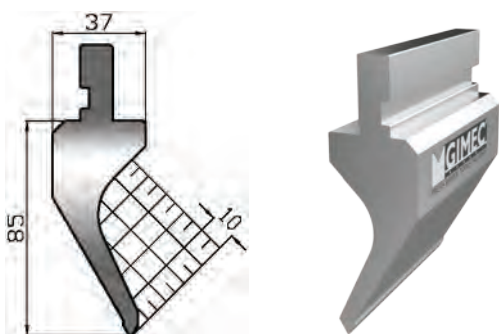

**US 132/60° R0,8**

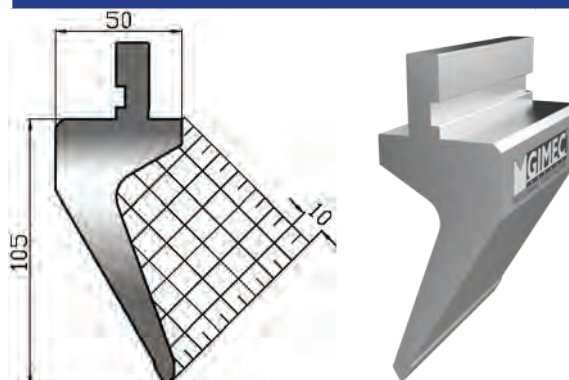

altezza height mm	angolo degree	raggio radius	acciaio steel	max kN/mt
85,0	60°	0,8	42CM4 T HRC 52-58	400
lunghezze - lengths		mm 835 - 415 - fraz 805 (1)		

altezza height mm	angolo degree	raggio radius	acciaio steel	max kN/mt
105,0	60°	0,8	42CM4 T HRC 52-58	700
lunghezze - lengths		mm 835 - 415 - fraz 805 (1)		

**US 128/60° R0,8**

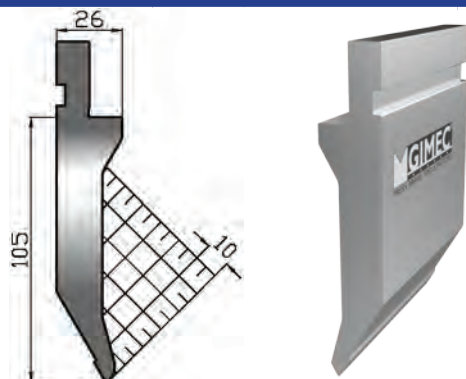

altezza height mm	angolo degree	raggio radius	acciaio steel	max kN/mt
105,0	60°	0,8	42CM4 T HRC 52-58	800
lunghezze - lengths		mm 835 - 415 - fraz 805 (1)		

**US 134/60° R0,8**

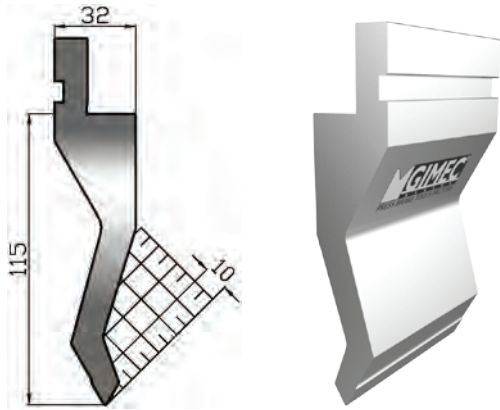

altezza height mm	angolo degree	raggio radius	acciaio steel	max kN/mt
115,0	60°	0,8	42CM4 T HRC 52-58	700
lunghezze - lengths			mm 835 - 415 - fraz 805 (1)	

**US 151/60° R0,8**

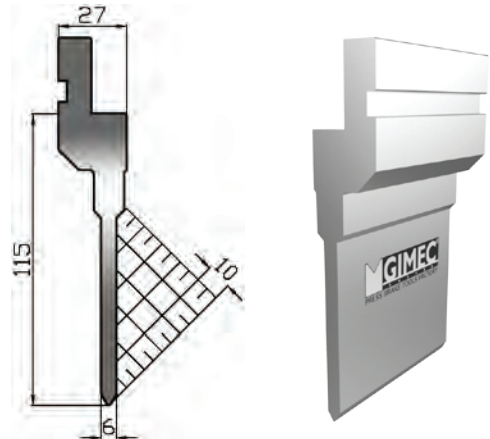

altezza height mm	angolo degree	raggio radius	acciaio steel	max kN/mt
115,0	60°	0,8	C45 T HRC 52-58	500
lunghezze - lengths			mm 835 - 415 - fraz 805 (1)	

**US 135/60° R0,8**

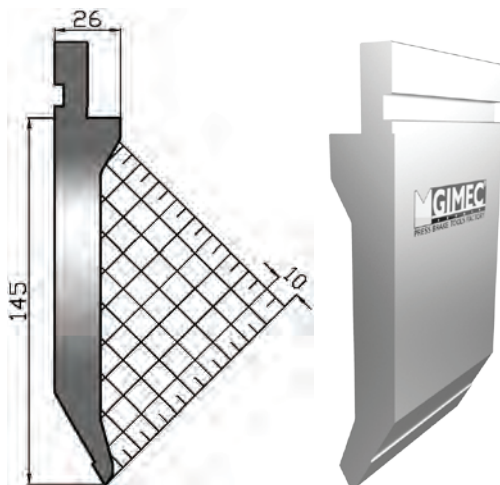

altezza height mm	angolo degree	raggio radius	acciaio steel	max kN/mt
145,0	60°	0,8	42CM4 T HRC 52-58	800
lunghezze - lengths			mm 835 - 415 - fraz 805 (1)	

**US 136/60° R2,0**

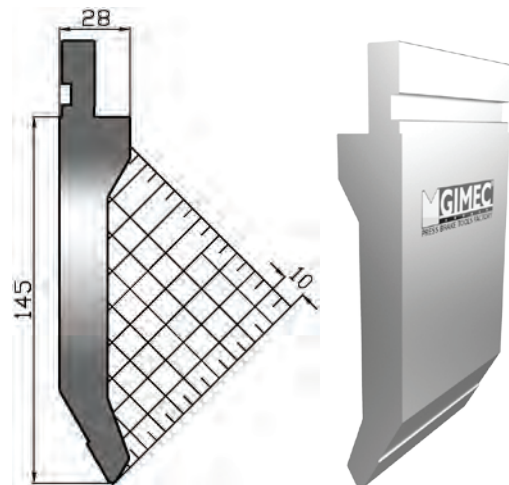

altezza height mm	angolo degree	raggio radius	acciaio steel	max kN/mt
145,0	60°	2,0	42CM4 T HRC 52-58	1000
lunghezze - lengths			mm 835 - 415 - fraz 805 (1)	

serie US®

STANDARD TOOLS

**US 155/60° R5,0**

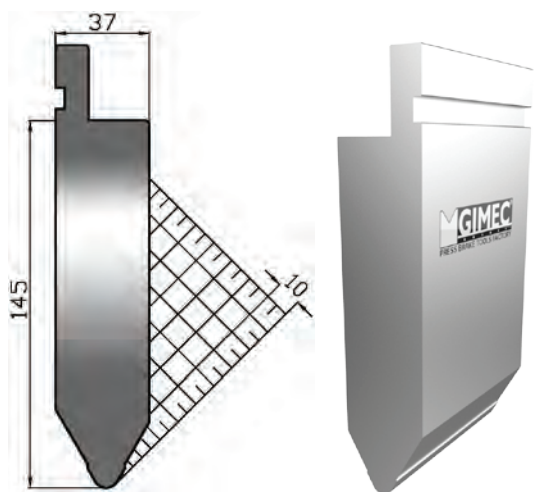

altezza height mm	angolo degree	raggio radius	acciaio steel	max kN/mt
145,0	60°	5,0	C45 T HRC 52÷58	1600
lunghezze - lengths		mm 835 - 415 - fraz 805 (1)		

**US 150/60° R0,8**

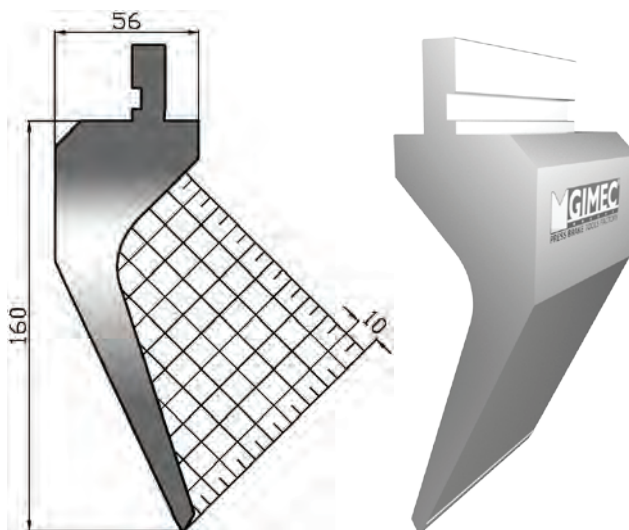

altezza height mm	angolo degree	raggio radius	acciaio steel	max kN/mt
160,0	60°	0,8	C45 T HRC 52÷58	400
lunghezze - lengths		mm 835 - 415 - fraz 805 (1)		



**trovali a pagina 21 e 38**  
find them on page 21 and 38

**US 111/45° R0,8**

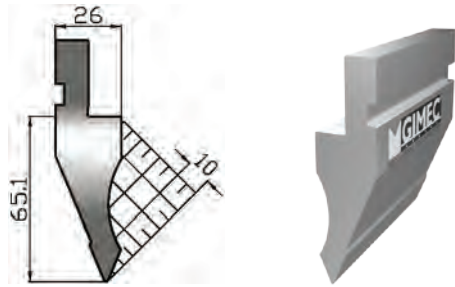

altezza height mm	angolo degree	raggio radius	acciaio steel	max kN/mt
65,1	45°	0,8	C45 T HRC 52÷58	800
lunghezze - lengths			mm 835 - 415 - fraz 805 (1)	

**US 111/45° R1,5**

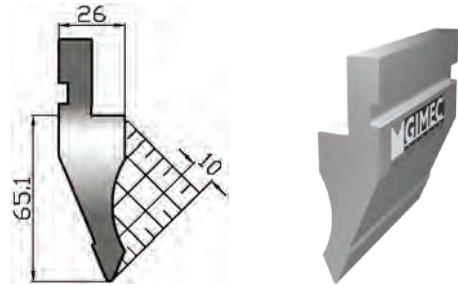

altezza height mm	angolo degree	raggio radius	acciaio steel	max kN/mt
65,1	45°	1,5	C45 T HRC 52÷58	800
lunghezze - lengths			mm 835 - 415 - fraz 805 (1)	

**US 149/45° R6,0**

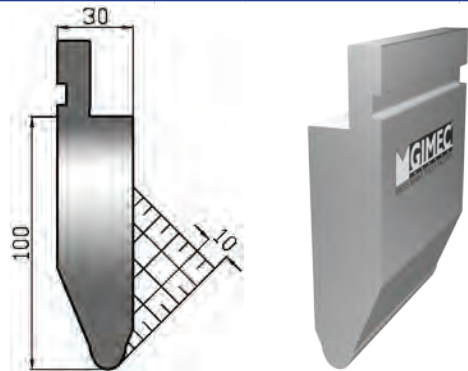

altezza height mm	angolo degree	raggio radius	acciaio steel	max kN/mt
100,0	45°	6,0	C45 T HRC 52÷58	1000
lunghezze - lengths			mm 835 - 415 - fraz 805 (1)	



serie US®

STANDARD TOOLS



**US 111/35° R0,8**

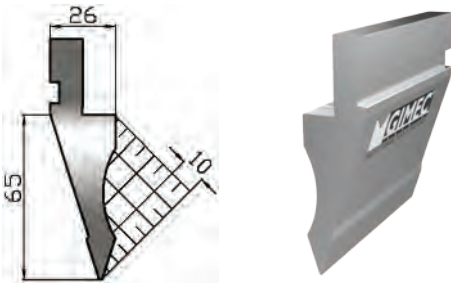

**US 113/35° R5,0**

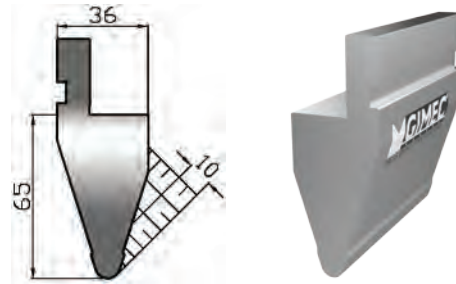

altezza height mm	angolo degree	raggio radius	acciaio steel	max kN/mt
65,0	35°	0,8	C45 T HRC 52÷58	500
lunghezze - lengths		mm 835 - 415 - fraz 805 (1)		

altezza height mm	angolo degree	raggio radius	acciaio steel	max kN/mt
65,0	35°	5,0	C45 T HRC 52÷58	1000
lunghezze - lengths		mm 835 - 415 - fraz 805 (1)		

**US 121/35° R0,8**

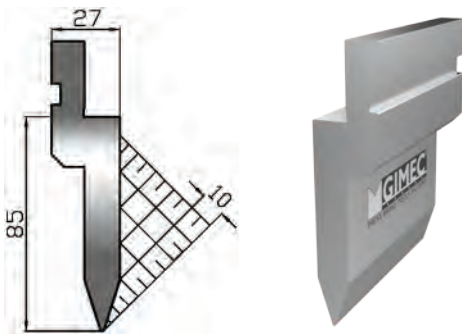

**US 121/35° R1,5**

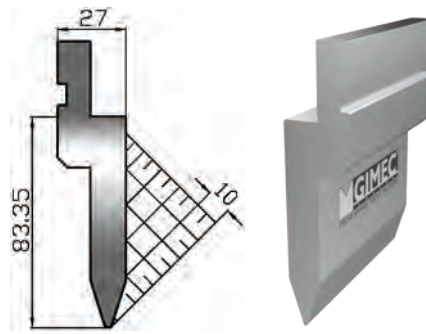

altezza height mm	angolo degree	raggio radius	acciaio steel	max kN/mt
85,0	35°	0,8	C45 T HRC 52÷58	1000
lunghezze - lengths		mm 835 - 415 - fraz 805 (1)		

altezza height mm	angolo degree	raggio radius	acciaio steel	max kN/mt
83,35	35°	1,5	C45 T HRC 52÷58	1000
lunghezze - lengths		mm 835 - 415 - fraz 805 (1)		

**US 112/35° R0,8 h 86 mm - h 90 mm**

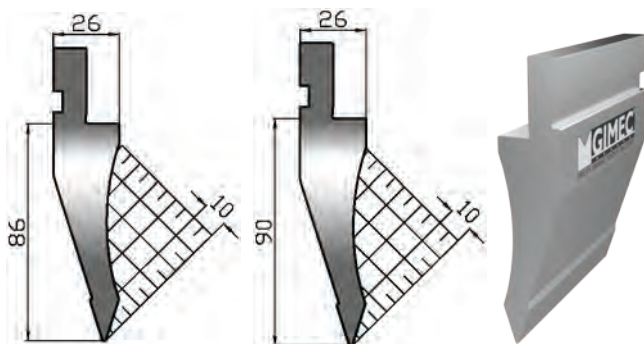

**US 112/35° R1,5 h86**

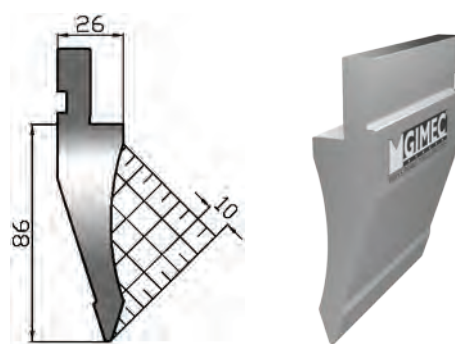

altezza height mm	angolo degree	raggio radius	acciaio steel	max kN/mt
86 - 90	35°	0,8	C45 T HRC 52÷58	700
lunghezze - lengths		mm 835 - 415 - fraz 805 (1)		

altezza height mm	angolo degree	raggio radius	acciaio steel	max kN/mt
86,0	35°	1,5	C45 T HRC 52÷58	700
lunghezze - lengths		mm 835 - 415 - fraz 805 (1)		

**US 133/30° R0,8**

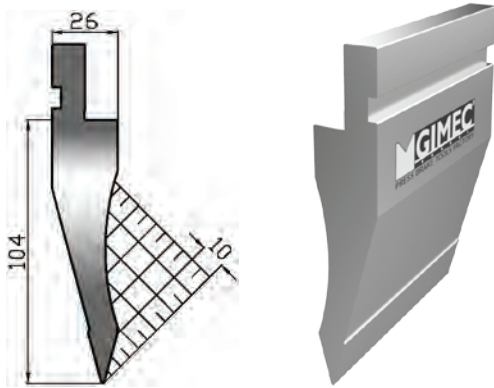

**US 159/30° R1,2**

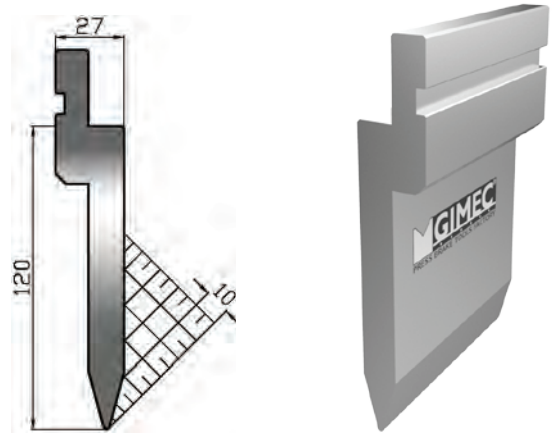

altezza height mm	angolo degree	raggio radius	acciaio steel	max kN/mt
104,0	30°	0,8	C45 T HRC 52÷58	700
lunghezze - lengths		mm 835 - 415 - fraz 805 (1)		

altezza height mm	angolo degree	raggio radius	acciaio steel	max kN/mt
120,0	30°	1,2	C45 T HRC 52÷58	1000
lunghezze-lengths		mm 500-550 fraz (1) mm 25+25+30+35+40+45+50+100+100SX-100DX		

**US 157/30° R0,6**

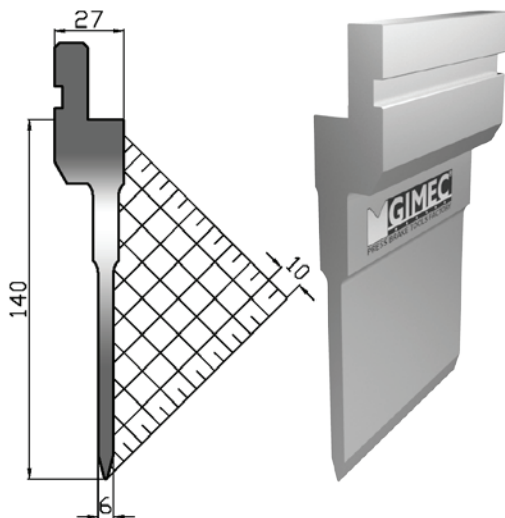

**US 154/30° R0,5**

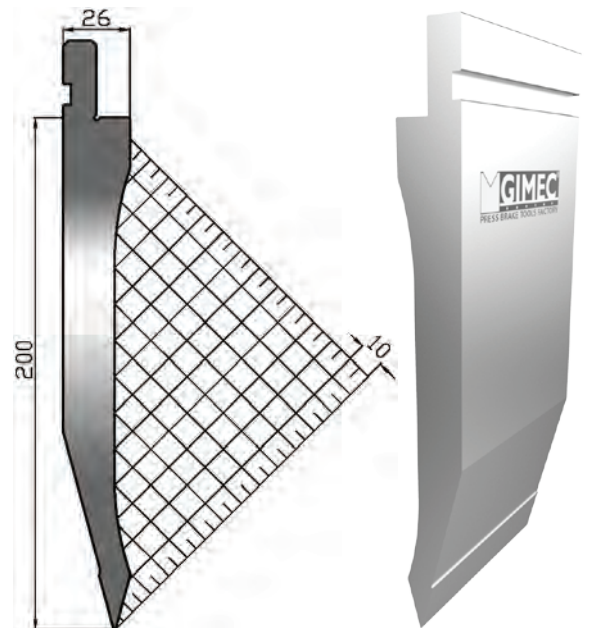

altezza height mm	angolo degree	raggio radius	acciaio steel	max kN/mt
140,0	30°	0,6	C45 T HRC 52÷58	400
lunghezze - lengths		mm 835 - 415 - fraz 805 (1)		

altezza height mm	angolo degree	raggio radius	acciaio steel	max kN/mt
200,0	30°	0,5	C45 T HRC 52÷58	500
lunghezze - lengths		mm 835 - 415 - fraz 805 (1)		

serie US®

STANDARD TOOLS

**US 122/26° R0,8**

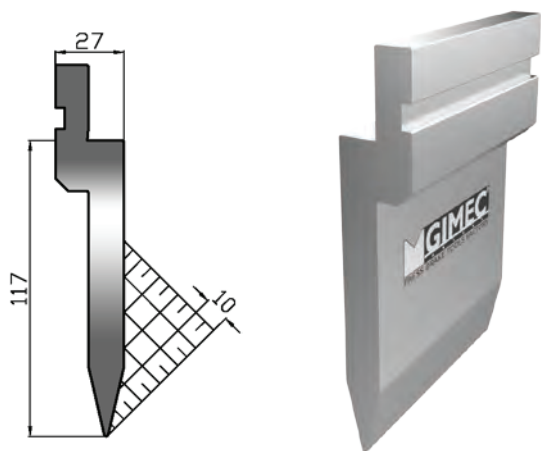

**US 122/26° R3,0**

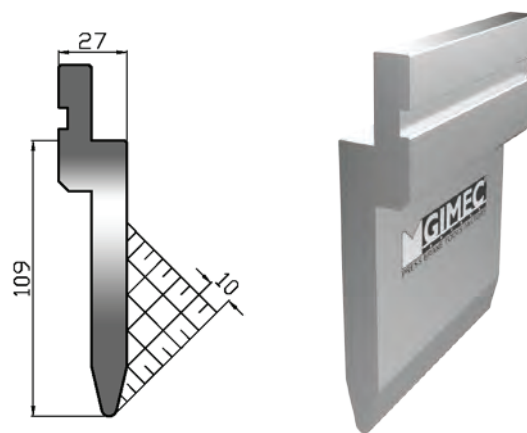

altezza height mm	angolo degree	raggio radius	acciaio steel	max kN/mt
117,0	26°	0,8	C45 T HRC 52-58	1000
lunghezze - lengths		mm 835 - 415 - fraz 805 (1)		

altezza height mm	angolo degree	raggio radius	acciaio steel	max kN/mt
109,0	26°	3,0	C45 T HRC 52-58	1000
lunghezze - lengths		mm 835 - 415 - fraz 805 (1)		

serie US®

**US 137/26° R0,8**

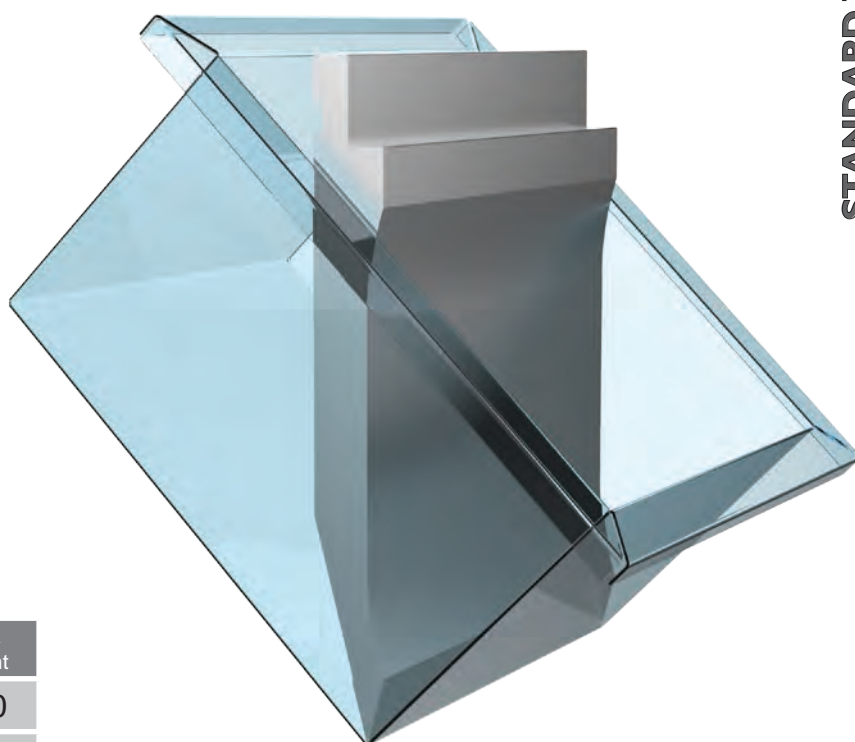
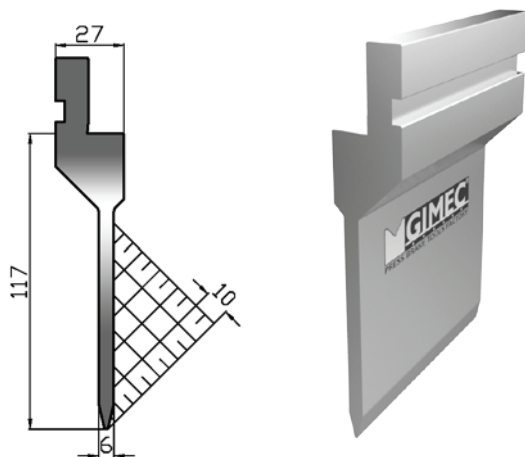

altezza height mm	angolo degree	raggio radius	acciaio steel	max kN/mt
117,0	26°	0,8	42CM4 T HRC 52-58	500
lunghezze - lengths		mm 835 - 415 - fraz 805 (1)		

STANDARD TOOLS

**US 139/26° R0,8**

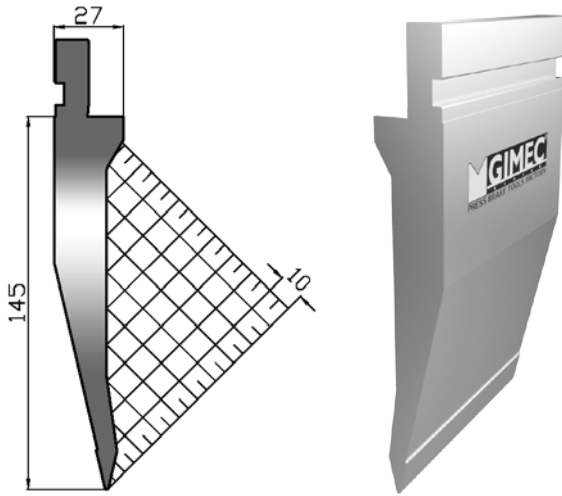

altezza height mm	angolo degree	raggio radius	acciaio steel	max kN/mt
145,0	26°	0,8	42CM4 T HRC 52-58	1000
lunghezze - lengths			mm 835 - 415 - fraz 805 (1)	

**US 140/26° R1,5**

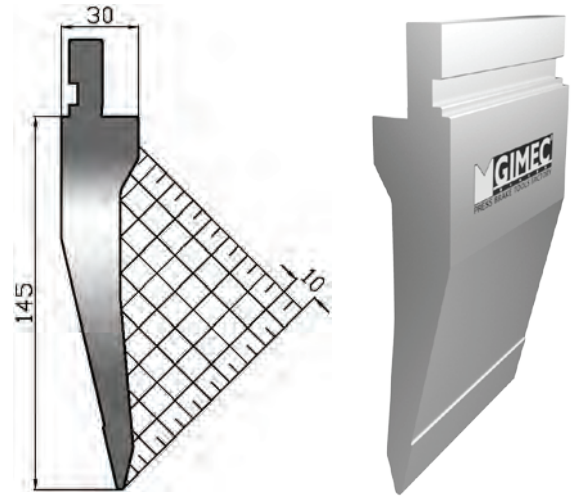

altezza height mm	angolo degree	raggio radius	acciaio steel	max kN/mt
145,0	26°	1,5	42CM4 T HRC 52-58	1000
lunghezze - lengths			mm 835 - 415 - fraz 805 (1)	

**US 175/26° R0,8**

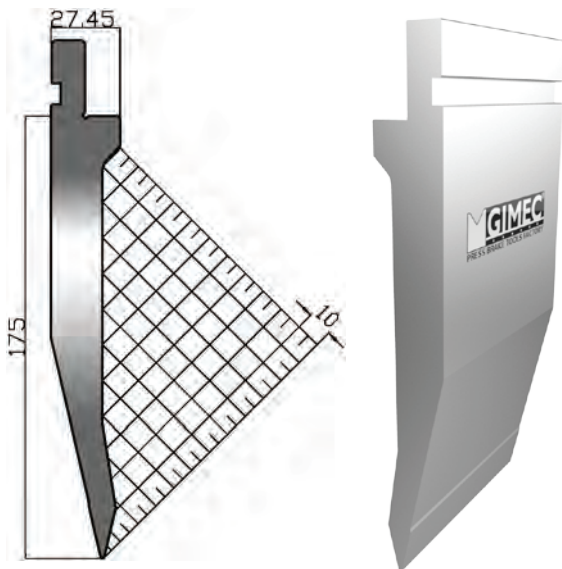

altezza height mm	angolo degree	raggio radius	acciaio steel	max kN/mt
175,0	26°	0,8	42CM4 T HRC 52-58	950
lunghezze - lengths			mm.525-fraz A495-B500 (2)	

**US 161/26° R1,0**

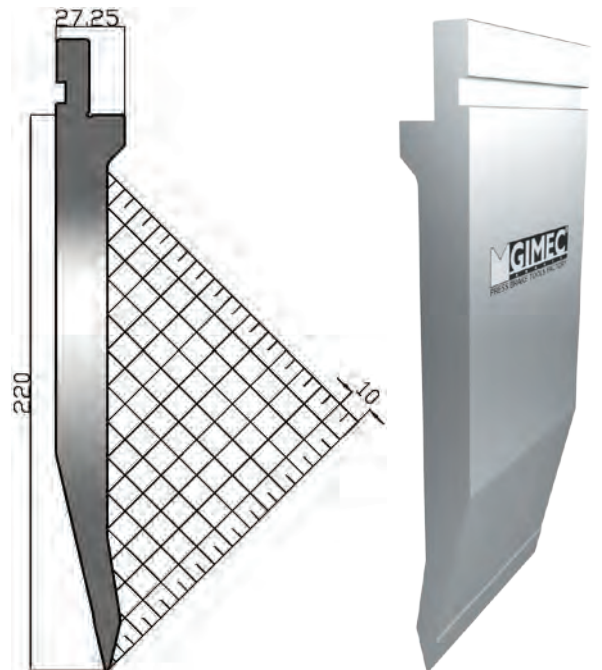

altezza height mm	angolo degree	raggio radius	acciaio steel	max kN/mt
220,0	26°	1,0	42CM4 T HRC 52-58	1000
lunghezze - lengths			mm.525-fraz A495-B500 (2)	

**US 119 h 67**



altezza height mm	raggio - radius MIN MAX		acciaio steel	max kN/mt
67,0	8,0	50,0	C45	800
lunghezze - lengths		mm 830 - 412		

**US 119 h 105**



altezza height mm	raggio - radius MIN MAX		acciaio steel	max kN/mt
105,0	8,0	50,0	C45	800
lunghezze - lengths		mm 830 - 412		

**US 119 C h 87**

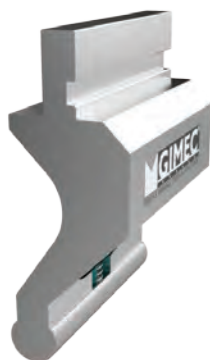
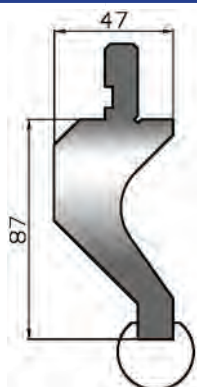

altezza height mm	raggio - radius MIN MAX		acciaio steel	max kN/mt
87,0	8,0	50,0	C45	500
lunghezze - lengths		mm 830 - 412		

**US 119 C h 115**

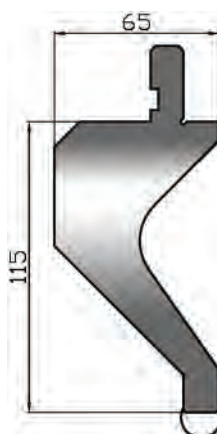

altezza height mm	raggio - radius MIN MAX		acciaio steel	max kN/mt
115,0	8,0	50,0	C45	500
lunghezze - lengths		mm 830 - 412		

**US 305 R 8 ÷ 50 mm**

4 fori-holes mm 104-209-...-104 = mm 835  
2 fori-holes mm 103-209-...-103 = mm 415

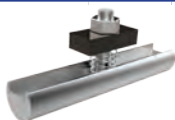
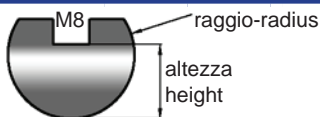

codice articolo item code	raggio radius	altezza height	codice articolo item code	raggio radius	altezza height
US 305/R 8	8	10 mm	US 305/R 25	25	29 mm
US 305/R 9	9	10 mm	US 305/R 27,5	27,5	34 mm
US 305/R 10	10	12 mm	US 305/R 30	30	34 mm
US 305/R 12,5	12,5	17 mm	US 305/R 35	35	45 mm
US 305/R 15	15	20 mm	US 305/R 40	40	44 mm
US 305/R 17,5	17,5	22 mm	US 305/R 45	45	50 mm
US 305/R 20	20	24 mm	US 305/R 50	50	54 mm
US 305/R 22,5	22,5	25 mm			
acciaio - steel		C45 - 39NCM3 nitruato (N)			
lunghezze - lengths		mm 835 - 415			

**US 310 - US 310 T**

4 fori-holes mm 104-209-...-104 = mm 835  
2 fori-holes mm 103-209-...-103 = mm 415

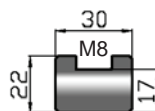

codice articolo item code	acciaio steel	
US 310	C45	
US 310 T	C45 T HRC 52÷58	
lunghezze - lengths		mm 835 - 415

**US 307 R 8**

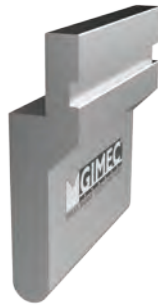
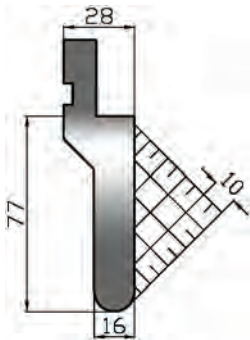

altezza height mm	raggio radius	acciaio steel	max kN/mt
77,0	8,0	C45 T HRC 52÷58	1000
lunghezze - lengths		mm 835 - 415 - fraz 805 (1)	

**US 307 R 9**

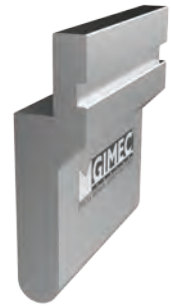
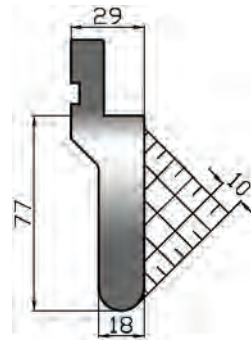

altezza height mm	raggio radius	acciaio steel	max kN/mt
77,0	9,0	C45 T HRC 52÷58	1000
lunghezze - lengths		mm 835 - 415 - fraz 805 (1)	

**US 307 R 10**

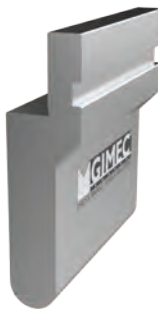
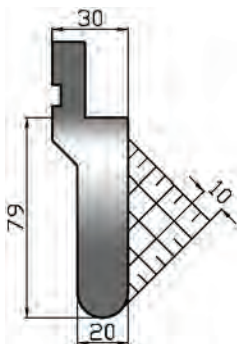

altezza height mm	raggio radius	acciaio steel	max kN/mt
79,0	10,0	C45 T HRC 52÷58	1000
lunghezze - lengths		mm 835 - 415 - fraz 805 (1)	

**US 307 R 12,5**

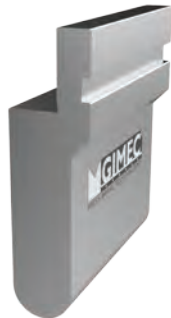
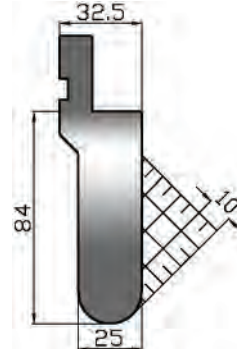

altezza height mm	raggio radius	acciaio steel	max kN/mt
84,0	12,5	C45 T HRC 52÷58	1000
lunghezze - lengths		mm 835 - 415 - fraz 805 (1)	

**US 307 R 15**

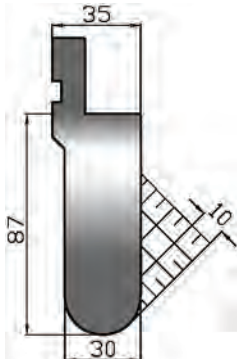

altezza height mm	raggio radius	acciaio steel	max kN/mt
87,0	15,0	C45 T HRC 52÷58	1000
lunghezze - lengths		mm 835 - 415 - fraz 805 (1)	

**US 307 R 17,5**

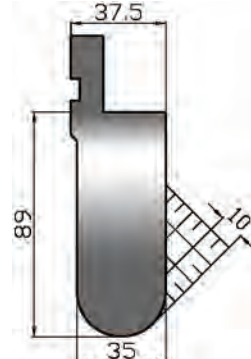

altezza height mm	raggio radius	acciaio steel	max kN/mt
89,0	17,5	C45 T HRC 52÷58	1000
lunghezze - lengths		mm 835 - 415 - fraz 805 (1)	

serie US®

STANDARD TOOLS

**US 307 R 20**

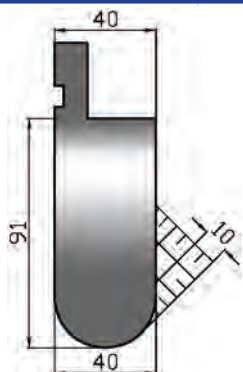

altezza height mm	raggio radius	acciaio steel	max kN/mt
91,0	20,0	C45 T HRC 52÷58	1000
lunghezze - lengths		mm 835 - 415 - fraz (1)	

**US 118 h 67** SPESSORE/THICKNESS MAX 3 mm



altezza height mm	raggio - radius MIN MAX		acciaio steel	max kN/mt
67,0	3,0	7,5	C45	400
lunghezze - lengths			mm 830 - 412	



**US 305 R 3 ÷ 7,5 mm**

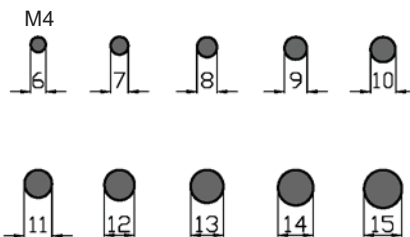

codice articolo item code	raggio radius	altezza height	codice articolo item code	raggio radius	altezza height
<b>US 305/R 3,0</b>	3,0	6 mm	<b>US 305/R 5,5</b>	5,5	11 mm
<b>US 305/R 3,5</b>	3,5	7 mm	<b>US 305/R 6,0</b>	6,0	12 mm
<b>US 305/R 4,0</b>	4,0	8 mm	<b>US 305/R 6,5</b>	6,5	13 mm
<b>US 305/R 4,5</b>	4,5	9 mm	<b>US 305/R 7,0</b>	7,0	14 mm
<b>US 305/R 5,0</b>	5,0	10 mm	<b>US 305/R 7,5</b>	7,5	15 mm
acciaio - steel			C45		
lunghezze - lengths			mm 835 - 415		



serie **US**®

**STANDARD TOOLS**

**US 130**

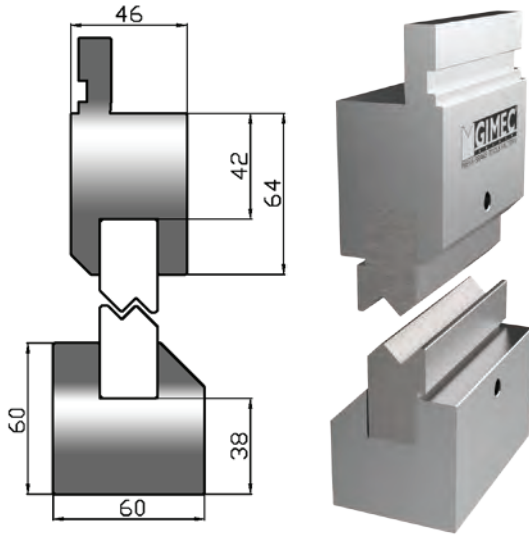

altezza height mm	acciaio steel	max kN/mt
64 + 60	C45	1000
lunghezze - lengths	mm 835 - 415	

**US 131 Z 1 ÷ 15**



codice articolo item code	Z mm	A°	MAX sp./th.
US 131 / 1,0	1,0	160°	0,5
US 131 / 1,5	1,5	160°	0,6
US 131 / 2,0	2,0	150°	0,8
US 131 / 2,5	2,5	140°	1,0
US 131 / 3,0	3,0	90°	1,0
US 131 / 3,5	3,5	90°	1,2
US 131 / 4,0	4,0	90°	1,2
US 131 / 4,5	4,5	90°	1,5
US 131 / 5,0	5,0	90°	1,5
US 131 / 5,5	5,5	90°	1,5
US 131 / 6,0	6,0	90°	1,5
US 131 / 6,5	6,5	90°	1,5
US 131 / 7,0	7,0	90°	2,0
US 131 / 7,5	7,5	90°	2,0
US 131 / 8	8	90°	2,5



US 131 / 9	9	90°	2,5
US 131 / 10	10	90°	3,0
US 131 / 11	11	90°	3,0
US 131 / 12	12	90°	3,0
US 131 / 13	13	90°	3,0
US 131 / 14	14	90°	3,0
US 131 / 15	15	90°	3,0

acciaio - steel	C45 T HRC 52÷58
lunghezze - lengths	mm 835 - 415

serie US®

STANDARD TOOLS





**ATTACCHI SPECIALI • SPECIAL CLAMPINGS**

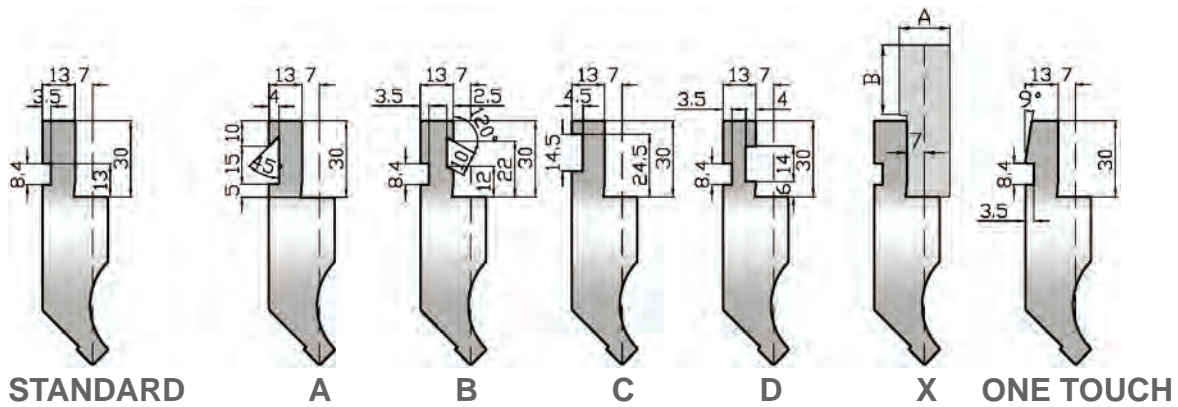

**LUNGHEZZE • LENGTHS mm 835 - 415 - fraz 805 mm (9 pz/pcs)**



**LUNGHEZZE • LENGTHS mm 525 - fraz A 495 mm (8 pz/pcs)- fraz B 500 mm (3 pz/pcs)  
US 175/85° R0,8 - US 175/85° R2,0 - US 175/26° R0,8 - US 161/26° R1,0**

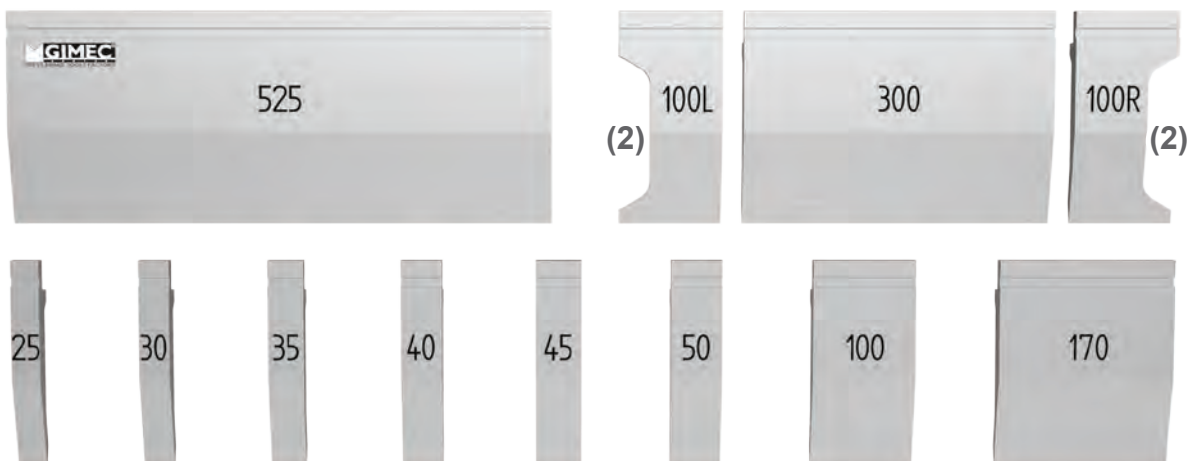

serie US®

STANDARD TOOLS

**USJ 120 P / 30° R0,8**

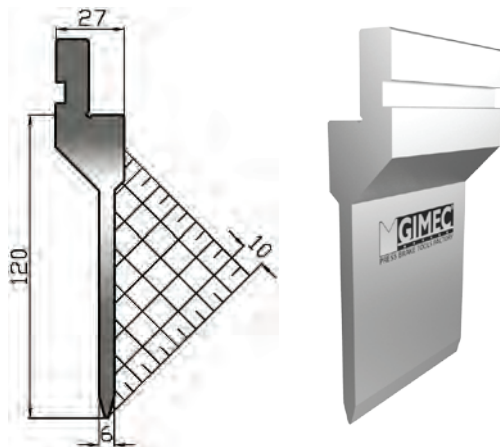

altezza height mm	angolo degree	raggio radius	acciaio steel	max kN/mt
120,0	30°	0,8	42CM4 T HRC 52-58	500
lunghezze - lengths			mm 835 - 415 - fraz 800 (1)	

**USJ 120 P / 88° R0,25**

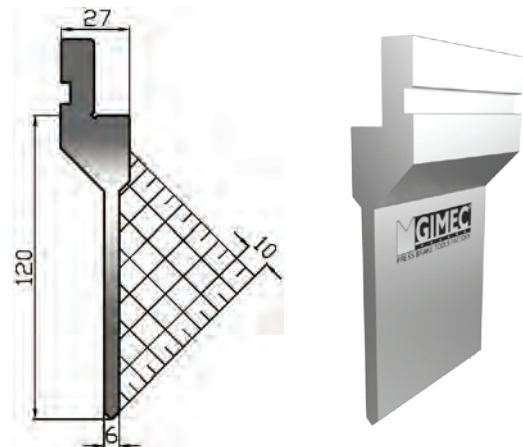

altezza height mm	angolo degree	raggio radius	acciaio steel	max kN/mt
120,0	88°	0,25	42CM4 T HRC 52-58	500
lunghezze - lengths			mm 835 - 415 - fraz 800 (1)	

**USJ 120 S / 86° R0,2**

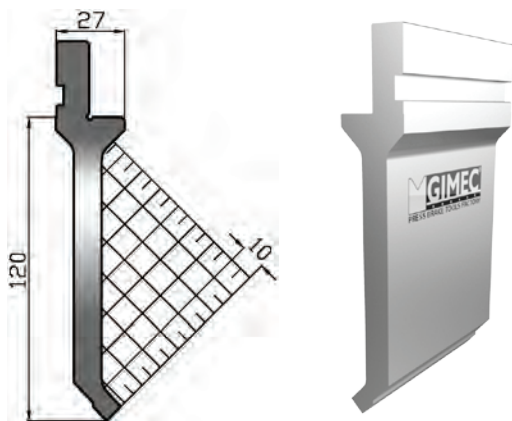

altezza height mm	angolo degree	raggio radius	acciaio steel	max kN/mt
120,0	86°	0,2	42CM4 T HRC 52-58	500
lunghezze - lengths			mm 835 - 415 - fraz 800 (1)	

**USJ 120 D / 86° R0,2**

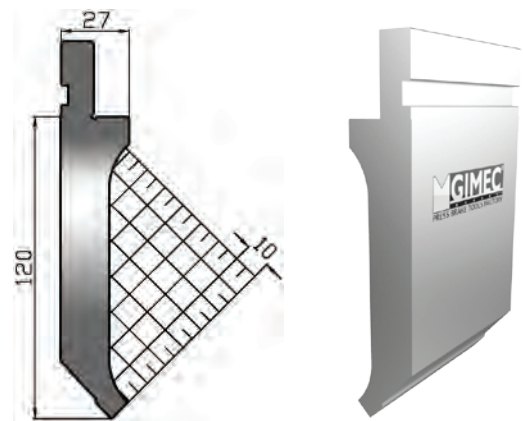

altezza height mm	angolo degree	raggio radius	acciaio steel	max kN/mt
120,0	86°	0,2	42CM4 T HRC 52-58	1000
lunghezze - lengths			mm 835 - 415 - fraz 800 (1)	

**LUNGHEZZE • LENGTHS mm 835 - 415 - fraz 800 mm (10 pz/pcs)**

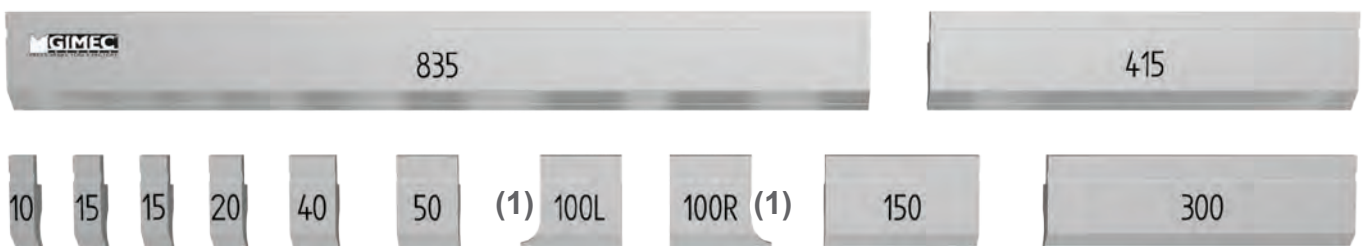

**USJ 120 C / 86° R0,2**

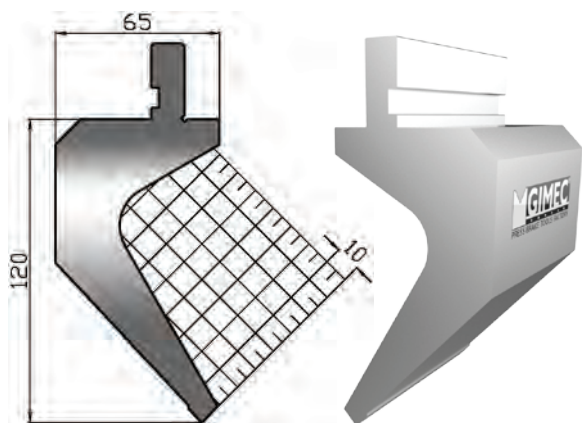

altezza height mm	angolo degree	raggio radius	acciaio steel	max kN/mt
120,0	86°	0,2	42CM4 T HRC 52-58	500
lunghezze - lengths		mm 835 - 415 - fraz 800 (1)		

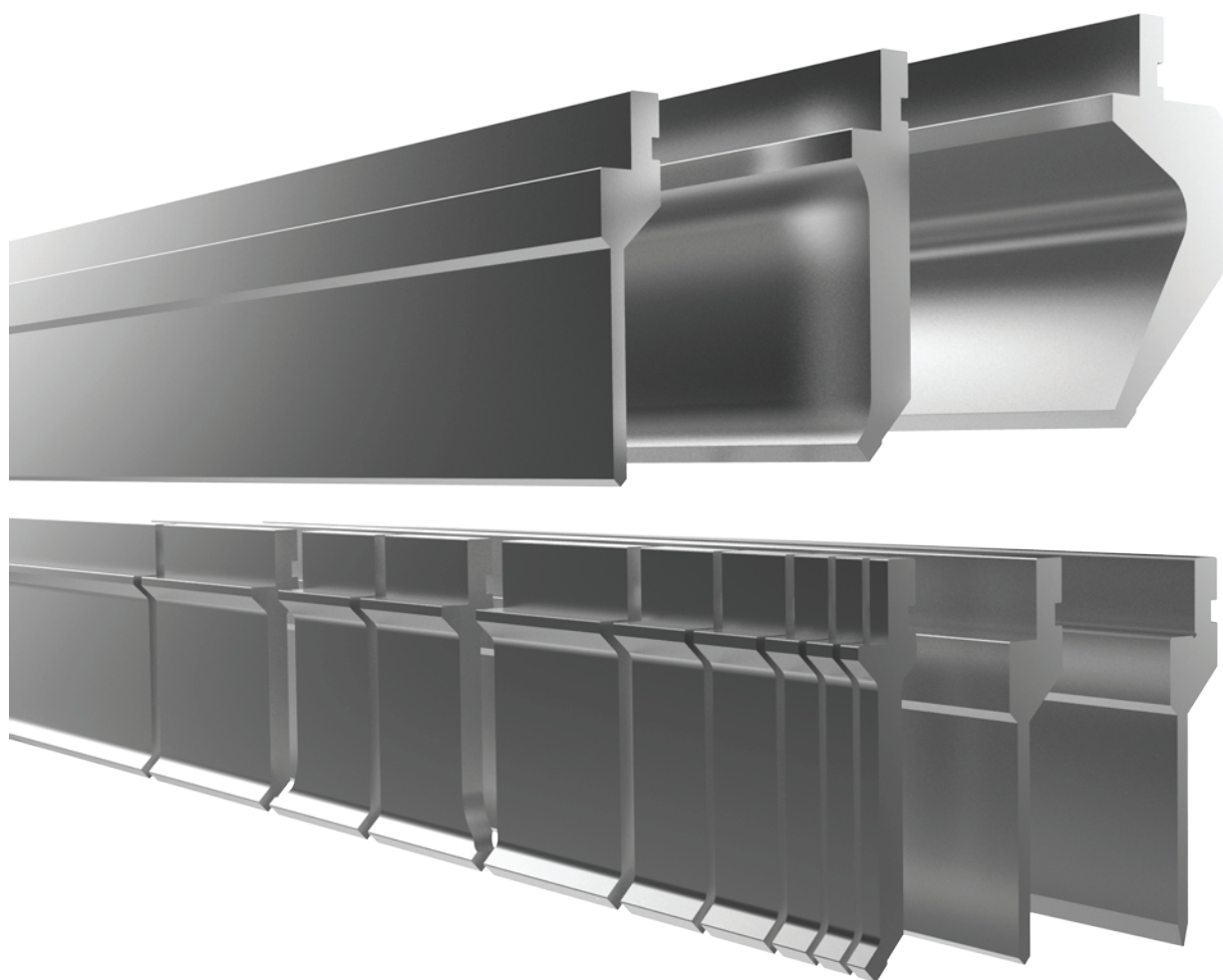

**serie USJ®**

**STANDARD TOOLS**

**altezza - height mm. 80**

acciaio - steel	C45 T HRC 52÷58
lunghezze - lengths	mm 835 - 415 - fraz

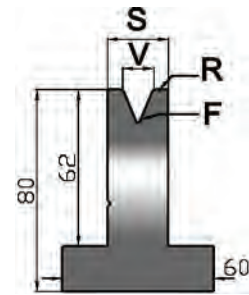

**US 220/26° h.mm.80**

**26°**

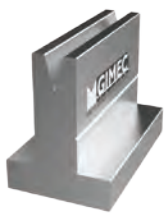

codice articolo item code	V mm	R mm	S mm	F mm	max kN/mt
US 220/26° V06	6	0,80	16	r 1,0	250
US 220/26° V08	8	1,00	20	r 1,0	250
US 220/26° V10	10	1,20	24	r 1,0	250
US 220/26° V12	12	1,60	26	r 1,0	250

**US 220/30° h.mm.80**

**30°**

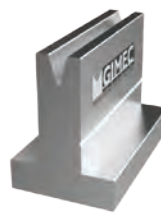

codice articolo item code	V mm	R mm	S mm	F mm	max kN/mt
US 220/30° V06	6	0,60	14	r 1,0	350
US 220/30° V08	8	0,80	18	r 1,2	350
US 220/30° V10	10	1,00	24	r 1,2	500
US 220/30° V12	12	1,50	24	r 1,2	400
US 220/30° V16	16	2,00	30	r 3,0	450
US 220/30° V20	20	2,50	35	r 3,0	500
US 220/30° V25	25	3,00	40	r 3,0	500

**US 220/35° h.mm.80**

**35°**



codice articolo item code	V mm	R mm	S mm	F mm	max kN/mt
US 220/35° V06	6	0,80	14	r 0,5	350
US 220/35° V08	8	1,00	16	r 0,5	350
US 220/35° V10	10	1,20	20	r 0,5	400
US 220/35° V12	12	1,60	22	r 0,5	400
US 220/35° V16	16	3,00	30	r 2,0	450
US 220/35° V20	20	3,00	35	r 2,0	500
US 220/35° V25	25	3,00	40	r 2,0	500

**US 220/45° h.mm.80**

**45°**

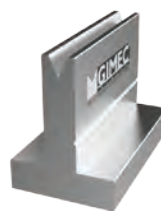

codice articolo item code	V mm	R mm	S mm	F mm	max kN/mt
US 220/45° V06	6	0,80	14	r 0,5	500
US 220/45° V08	8	1,00	18	r 0,8	500
US 220/45° V10	10	1,20	18	r 0,8	500
US 220/45° V12	12	1,60	24	r 0,8	500
US 220/45° V16	16	2,75	26	r 2,0	500
US 220/45° V20	20	3,00	30	r 2,0	600
US 220/45° V25	25	3,00	37	r 2,0	700

**US 220/60° h.mm.80**

**60°**

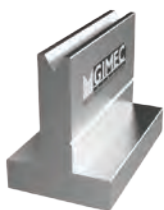

codice articolo item code	V mm	R mm	S mm	F mm	max kN/mt
US 220/60° V06	6	0,50	14	r 0,5	800
US 220/60° V08	8	0,80	14	r 0,5	700
US 220/60° V10	10	0,80	18	r 0,5	800
US 220/60° V12	12	0,80	18	r 0,5	700
US 220/60° V16	16	2,75	24	r 2,0	1000
US 220/60° V20	20	3,00	30	r 2,0	1000
US 220/60° V25	25	3,00	35	r 2,0	1000
US 220/60°V06R	6	1,50	14	r 0,5	800
US 220/60°V08R	8	1,50	14	r 0,5	700
US 220/60°V10R	10	2,75	18	r 0,5	800
US 220/60°V12R	12	2,75	18	r 0,5	700

**US 220/88° h.mm.80**

**88°**

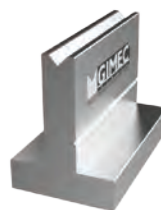

codice articolo item code	V mm	R mm	S mm	F mm	max kN/mt
US 220/88° V06	6	0,40	14	r 0,5	1000
US 220/88° V08	8	0,50	14	r 0,5	1000
US 220/88° V10	10	0,80	18	r 0,5	1000
US 220/88° V12	12	2,75	18	r 0,5	1000
US 220/88° V16	16	2,75	24	r 0,5	1000
US 220/88° V20	20	3,00	30	r 0,5	1000
US 220/88° V25	25	3,00	35	r 0,5	1000
US 220/88°V06R	6	2,75	14	r 0,5	1000
US 220/88°V08R	8	2,75	14	r 0,5	1000
US 220/88°V10R	10	2,75	18	r 0,5	1000

**US 220/85° h.mm.80**

**85°**

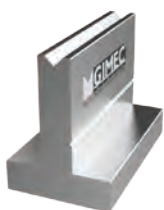

codice articolo item code	V mm	R mm	S mm	F mm	max kN/mt
US 220/85° V06	6	2,75	14	r 0,5	1000
US 220/85° V08	8	2,75	14	r 0,5	1000
US 220/85° V10	10	2,75	18	r 0,5	1000
US 220/85° V12	12	2,75	18	r 0,5	1000
US 220/85° V16	16	2,75	24	r 0,5	1000
US 220/85° V20	20	3,00	30	r 0,8	1000
US 220/85° V25	25	3,00	35	r 0,8	1000

**US 220/90° h.mm.80**

**90°**

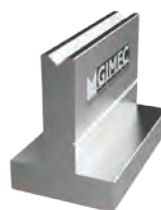

codice articolo item code	V mm	R mm	S mm	F mm	max kN/mt
US 220/90° V06	6	0,40	14	r 0,5	1000
US 220/90° V08	8	0,50	14	r 0,5	1000
US 220/90° V10	10	0,60	18	r 0,5	1000
US 220/90° V12	12	0,80	18	r 0,5	1000

serie 60®

STANDARD TOOLS

**altezza - height mm. 120**

acciaio - steel	C45 T HRC 52-58
lunghezze - lengths	mm 835 - 415 - fraz

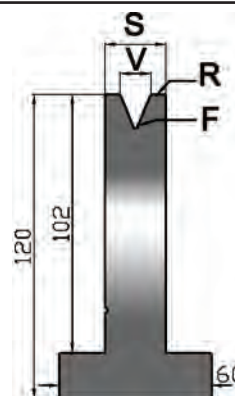

US 420/26° h.mm.120		26°				
	codice articolo item code	V mm	R mm	S mm	F mm	max kN/mt
	US 420/26° V06	6	0,80	16	r 1,0	250
	US 420/26° V08	8	1,00	20	r 1,0	250
	US 420/26° V10	10	1,20	24	r 1,0	250
	US 420/26° V12	12	1,60	26	r 1,0	250

US 420/30° h.mm.120		30°				
	codice articolo item code	V mm	R mm	S mm	F mm	max kN/mt
	US 420/30° V06	6	0,60	14	r 1,0	350
	US 420/30° V08	8	0,80	18	r 1,2	350
	US 420/30° V10	10	1,00	24	r 1,2	500
	US 420/30° V12	12	1,50	24	r 1,2	400
	US 420/30° V16	16	2,00	30	r 3,0	450
	US 420/30° V20	20	2,50	35	r 3,0	500
	US 420/30° V25	25	3,00	40	r 3,0	500

US 420/35° h.mm.120		35°				
	codice articolo item code	V mm	R mm	S mm	F mm	max kN/mt
	US 420/35° V06	6	0,80	14	r 0,5	350
	US 420/35° V08	8	1,00	16	r 0,5	350
	US 420/35° V10	10	1,20	20	r 0,5	400
	US 420/35° V12	12	1,60	22	r 0,5	400
	US 420/35° V16	16	3,00	30	r 2,0	450
	US 420/35° V20	20	3,00	35	r 2,0	500
	US 420/35° V25	25	3,00	40	r 2,0	500

US 420/45° h.mm.120		45°				
	codice articolo item code	V mm	R mm	S mm	F mm	max kN/mt
	US 420/45° V06	6	0,80	14	r 0,5	500
	US 420/45° V08	8	1,00	18	r 0,8	500
	US 420/45° V10	10	1,20	18	r 0,8	500
	US 420/45° V12	12	1,60	24	r 0,8	500
	US 420/45° V16	16	2,75	26	r 2,0	500
	US 420/45° V20	20	3,00	30	r 2,0	600
	US 420/45° V25	25	3,00	37	r 2,0	700

US 420/60° h.mm.120		60°					
	codice articolo item code	V mm	R mm	S mm	F mm	max kN/mt	
	US 420/60° V06	6	0,50	14	r 0,5	800	
	US 420/60° V08	8	0,80	14	r 0,5	700	
	US 420/60° V10	10	0,80	18	r 0,5	800	
	US 420/60° V12	12	0,80	18	r 0,5	700	
	US 420/60° V16	16	2,75	24	r 2,0	1000	
	US 420/60° V20	20	3,00	30	r 2,0	1000	
	US 420/60° V25	25	3,00	35	r 2,0	1000	
		US 420/60°V06R	6	1,50	14	r 0,5	800
		US 420/60°V08R	8	1,50	14	r 0,5	700
		US 420/60°V10R	10	2,75	18	r 0,5	800
		US 420/60°V12R	12	2,75	18	r 0,5	700

US 420/88° h.mm.120		88°					
	codice articolo item code	V mm	R mm	S mm	F mm	max kN/mt	
	US 420/88° V06	6	0,40	14	r 0,5	1000	
	US 420/88° V08	8	0,50	14	r 0,5	1000	
	US 420/88° V10	10	0,80	18	r 0,5	1000	
	US 420/88° V12	12	2,75	18	r 0,5	1000	
	US 420/88° V16	16	2,75	24	r 0,5	1000	
	US 420/88° V20	20	3,00	30	r 0,5	1000	
	US 420/88° V25	25	3,00	35	r 0,5	1000	
		US 420/88°V06R	6	2,75	14	r 0,5	1000
		US 420/88°V08R	8	2,75	14	r 0,5	1000
		US 420/88°V10R	10	2,75	18	r 0,5	1000

US 420/85° h.mm.120		85°				
	codice articolo item code	V mm	R mm	S mm	F mm	max kN/mt
	US 420/85° V06	6	2,75	14	r 0,5	1000
	US 420/85° V08	8	2,75	14	r 0,5	1000
	US 420/85° V10	10	2,75	18	r 0,5	1000
	US 420/85° V12	12	2,75	18	r 0,5	1000
	US 420/85° V16	16	2,75	24	r 0,5	1000
	US 420/85° V20	20	3,00	30	r 0,8	1000
	US 420/85° V25	25	3,00	35	r 0,8	1000

US 420/90° h.mm.120		90°				
	codice articolo item code	V mm	R mm	S mm	F mm	max kN/mt
	US 420/90° V06	6	0,40	14	r 0,5	1000
	US 420/90° V08	8	0,50	14	r 0,5	1000
	US 420/90° V10	10	0,60	18	r 0,5	1000
	US 420/90° V12	12	0,80	18	r 0,5	1000

**serie 60®**

**STANDARD TOOLS**

**US 205/4V (85°)**

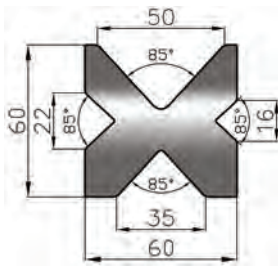

V	16	22	35	50	acciaio steel	max kN/mt
raggio radius	mm 2	mm 2	mm 2	mm 3	C45 T HRC 52÷58	800
lunghezze - lengths				mm 835 - 415 - fraz		

**US 209/4V (85° 88°)**

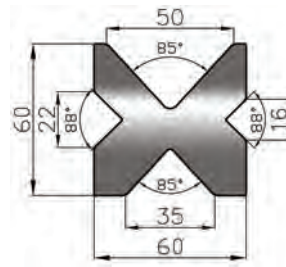

V	16	22	35	50	acciaio steel	max kN/mt
raggio radius	mm 2	mm 2	mm 2	mm 3	C45 T HRC 52÷58	800
lunghezze - lengths				mm 835 - 415 - fraz		

**US 210/4V (60°)**

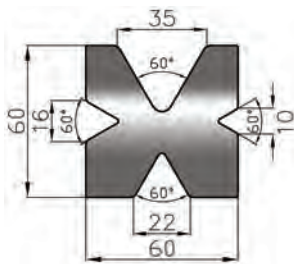

V	10	16	22	35	acciaio steel	max kN/mt
raggio radius	mm 1,5	mm 2	mm 2,5	mm 3	C45 T HRC 52÷58	600
lunghezze - lengths				mm 835 - 415 - fraz		

**US 208/3U**

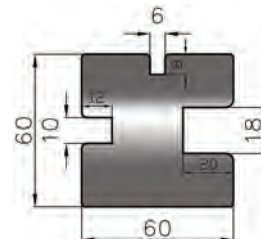

U	6	10	18	acciaio steel	max kN/mt	
raggio radius	mm 1,5	mm 2	mm 3,0	C45 T HRC 52÷58	1000	
lunghezze - lengths				mm 835 - 415 - fraz		

**US 203/4V (80° 60°)**

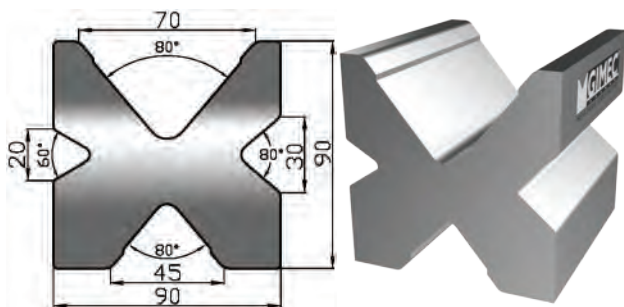

V	20	30	45	70	acciaio steel	max kN/mt
raggio radius	mm 2	mm 4	mm 4	mm 5	C45 T HRC 52÷58	600
lunghezze - lengths				mm 835 - 415 - fraz		

**US 204/4V (80° 60°)**

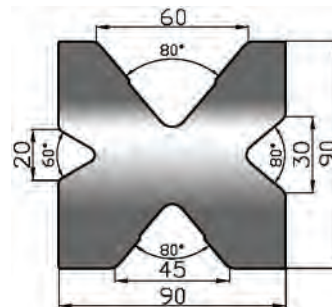

V	20	30	45	60	acciaio steel	max kN/mt
raggio radius	mm 2	mm 4	mm 4	mm 5	C45 T HRC 52÷58	1000
lunghezze - lengths				mm 835 - 415 - fraz		

serie 60®

STANDARD TOOLS

**US 216/90° V 6 + 10**

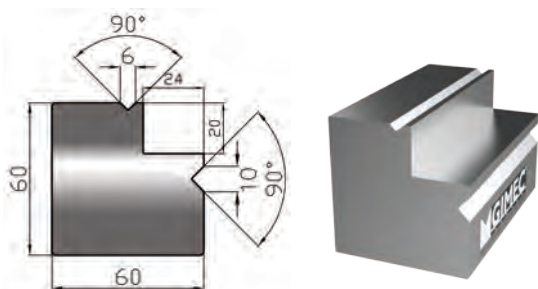

V 90°	mm 6	mm 10	acciaio steel	max kN/mt
raggio radius	mm 0,4	mm 0,6	C45 T HRC 52÷58	800
lunghezze - lengths		mm 835 - 415 - fraz		

**US 217/90° V8 + 12**

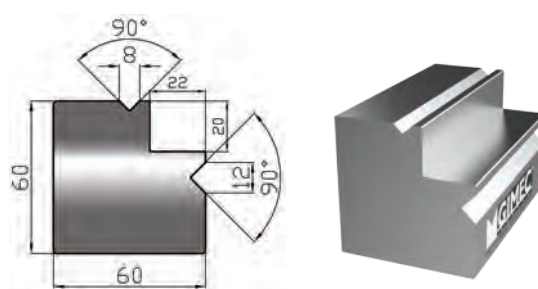

V 90°	mm 8	mm 12	acciaio steel	max kN/mt
raggio radius	mm 0,5	mm 0,8	C45 T HRC 52÷58	800
lunghezze - lengths		mm 835 - 415 - fraz		

**US 211/85° V 32**

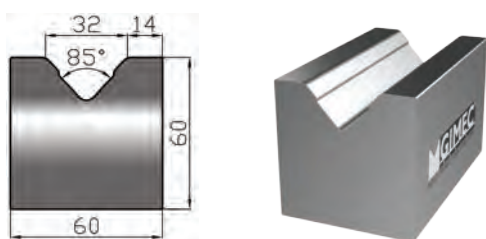

V/85°	altezza height	raggio radius	acciaio steel	max kN/mt
mm 32	mm 60	4,0	C45 T HRC 52÷58	1000
lunghezze - lengths		mm 835 - 415 - fraz		

**US 220/45° V 32**

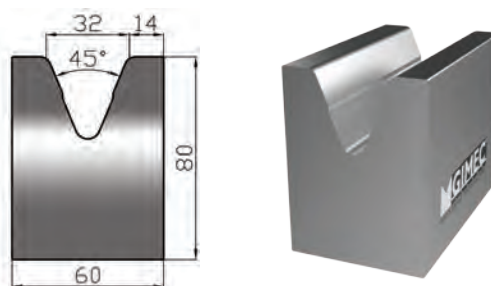

V/45°	altezza height	raggio radius	acciaio steel	max kN/mt
mm 32	mm 80	4,0	C45 T HRC 52÷58	1000
lunghezze - lengths		mm 835 - 415 - fraz		

**US 211/85° V 40**

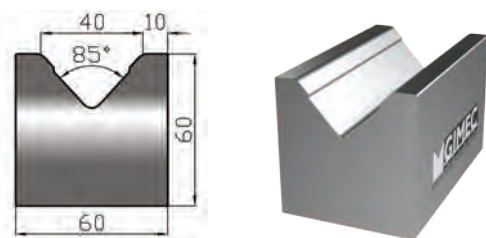

V/85°	altezza height	raggio radius	acciaio steel	max kN/mt
mm 40	mm 60	4,0	C45 T HRC 52÷58	1000
lunghezze - lengths		mm 835 - 415 - fraz		

**US 220/45° V 40**

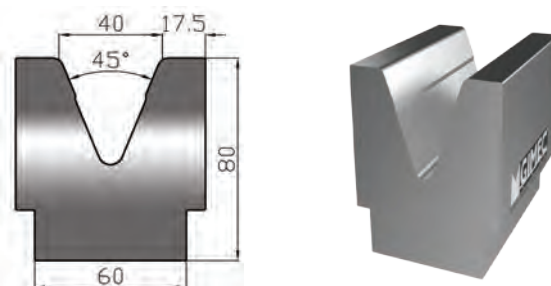

V/45°	altezza height	raggio radius	acciaio steel	max kN/mt
mm 40	mm 80	4,0	C45 T HRC 52÷58	1000
lunghezze - lengths		mm 835 - 415 - fraz		

**US 211/85° V 50**

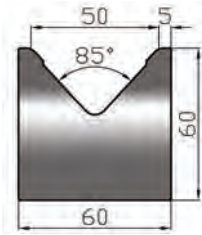

V/85°	altezza height	raggio radius	acciaio steel	max kN/mt
mm 50	mm 60	4,0	C45 T HRC 52-58	1000
lunghezze - lengths		mm 835 - 415 - fraz		

**US 220/45° V 50**

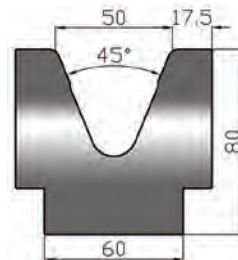

V/45°	altezza height	raggio radius	acciaio steel	max kN/mt
mm 50	mm 80	4,0	C45 T HRC 52-58	900
lunghezze - lengths		mm 835 - 415 - fraz		

**US 211/85° V 63**

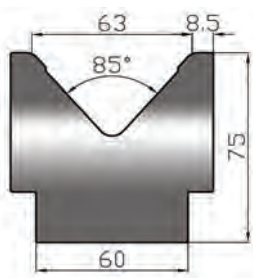

V/85°	altezza height	raggio radius	acciaio steel	max kN/mt
mm 63	mm 75	5,0	C45 T HRC 52-58	1000
lunghezze - lengths		mm 835 - 415 - fraz		

**US 220/60° V 63**

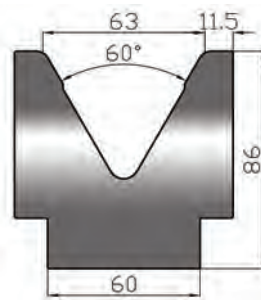

V/60°	altezza height	raggio radius	acciaio steel	max kN/mt
mm 63	mm 86	5,0	C45 T HRC 52-58	1000
lunghezze - lengths		mm 835 - 415 - fraz		

**US 211/85° V 80**

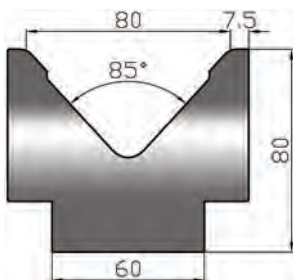

V/85°	altezza height	raggio radius	acciaio steel	max kN/mt
mm 80	mm 80	6,0	C45 T HRC 52-58	1000
lunghezze - lengths		mm 835 - 415 - fraz		

**US 220/60° V 80**

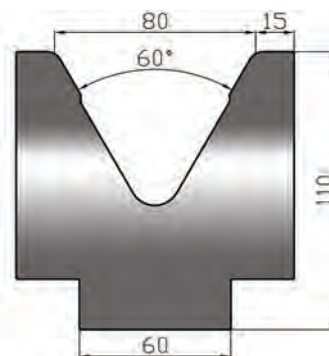

V/60°	altezza height	raggio radius	acciaio steel	max kN/mt
mm 80	mm 110	6,0	C45 T HRC 52-58	1000
lunghezze - lengths		mm 835 - 415 - fraz		

serie 60®

STANDARD TOOLS



**US 211/80° V 100**

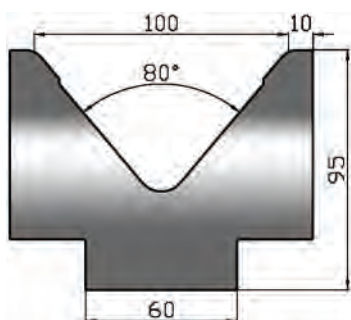

V/80°	altezza height	raggio radius	acciaio steel	max kN/mt
mm 100	mm 95	8,0	C45 T HRC 52-58	1000
lunghezze - lengths			mm 835 - 415 - fraz	

**US 220/60° V 100**

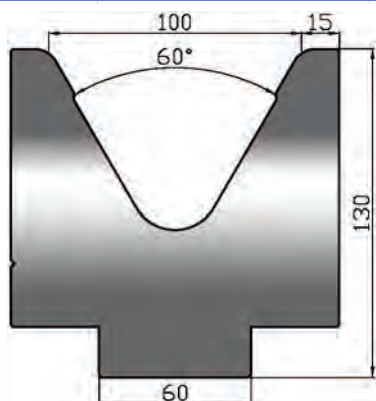

V/60°	altezza height	raggio radius	acciaio steel	max kN/mt
mm 100	mm 130	10,0	C45 T HRC 52-58	1000
lunghezze - lengths			mm 835 - 415 - fraz	

**US 211/80° V 125 base mm 90**

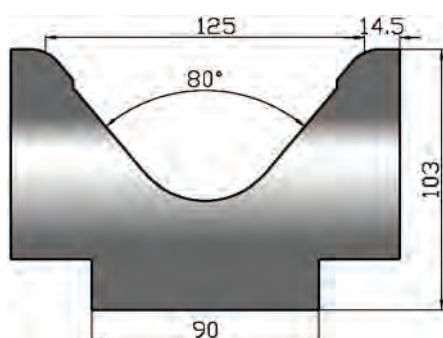

V/80°	altezza height	raggio radius	acciaio steel	max kN/mt
mm 125	mm 103	15,0	C45 T HRC 52-58	1000
lunghezze - lengths			mm 835 - 415 - fraz	

serie 60®

STANDARD TOOLS

**US 211/80° V 160 base mm 90**

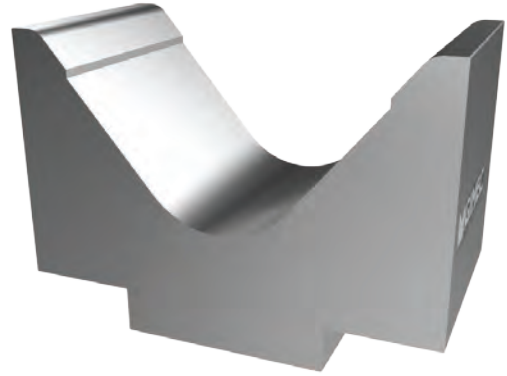
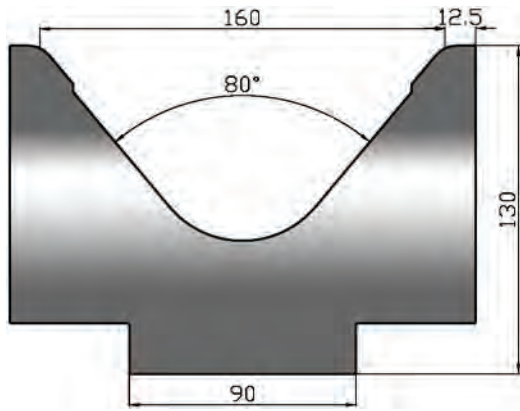

V/80°	altezza height	raggio radius	acciaio steel	max kN/mt
mm 160	mm 130	10,0	C45 T HRC 52-58	1000
lunghezze - lengths			mm 835 - 415 - fraz	

**US 211/70° V 200 base mm 120**

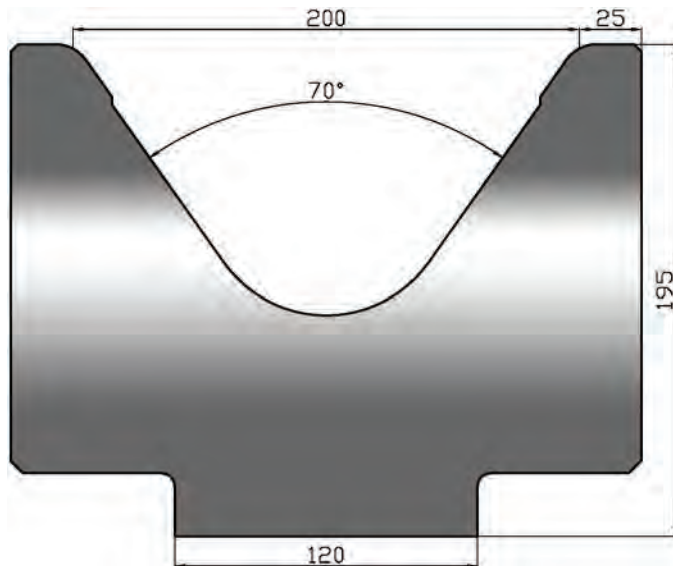

V/70°	altezza height	raggio radius	acciaio steel	max kN/mt
mm 200	mm 195	15,0	42CM4 T HRC 52-58	1800
lunghezze - lengths			mm 415 - fraz	

**US 138 L 8**

**US 138 M 8**

**US 138 L 10**

**US 138 M 10**

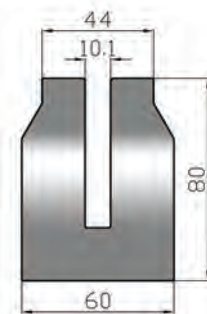
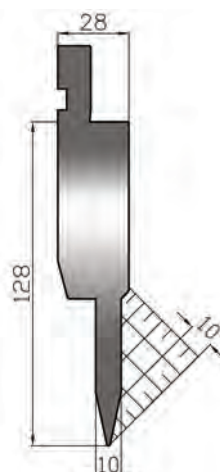
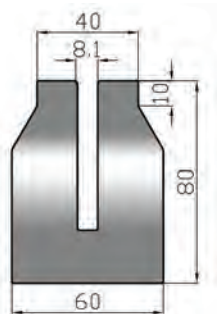
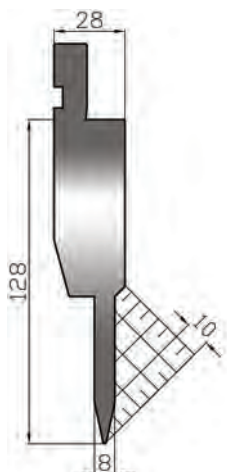

altezza height	angolo degree	raggio radius	max kN/mt	altezza height	V mm	raggio radius	max kN/mt
mm 128	24°	0,6	800	mm 80	mm 8	1,0	500
acciaio - steel				42CM4 T HRC52-58			
lunghezze - lengths				mm 835 - 415 - fraz			

altezza height	angolo degree	raggio radius	max kN/mt	altezza height	V mm	raggio radius	max kN/mt
mm 128	24°	0,6	800	mm 80	mm10	1,0	500
acciaio - steel				42CM4 T HRC52-58			
lunghezze - lengths				mm 835 - 415 - fraz			

**US 138 L 12**

**US 138 M 12**

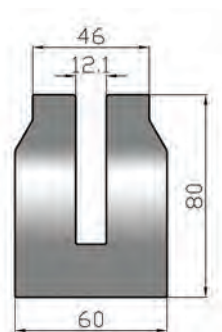
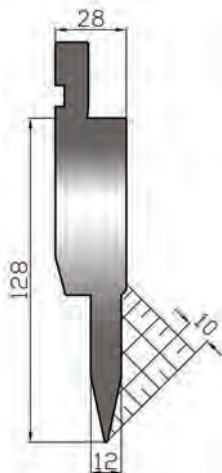

altezza height	angolo degree	raggio radius	max kN/mt	altezza height	V mm	raggio radius	max kN/mt
mm 128	24°	0,6	800	mm 80	mm12	1,0	500
acciaio - steel				42CM4 T HRC52-58			
lunghezze - lengths				mm 835 - 415 - fraz			



serie 60®

STANDARD TOOLS

Si consiglia di utilizzare questi utensili su presse piegatrici sincronizzate in quanto occorre variare rapidamente la corsa della pressa tra la fase di piegatura e quella di schiacciatura. Non è possibile aumentare il raggio della matrice in quanto si potrebbero verificare deformazioni anomale della piega schiacciata.

We suggest to use these tools on synchronized press brakes as it is necessary to change quickly the press stroke between bending and crushing position. It is not possible to increase lower tool radius because it would have some deformations on the flattened.

**US 303/35° V6**

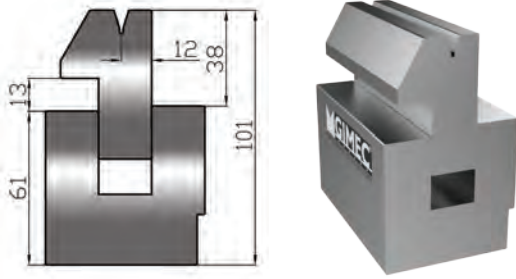

V mm	altezza height	raggio radius	acciaio steel	max kN/mt
6/35°	mm 101-88	1,0	C45 T HRC 52÷58	600
lunghezze - lengths		mm 835 - 415		

**US 303/35° V8**

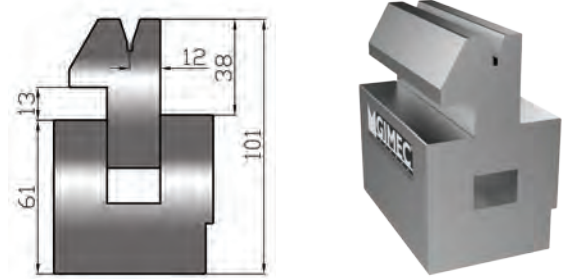

V mm	altezza height	raggio radius	acciaio steel	max kN/mt
8/35°	mm 101-88	1,0	C45 T HRC 52÷58	600
lunghezze - lengths		mm 835 - 415		

**US 306/30° V8**

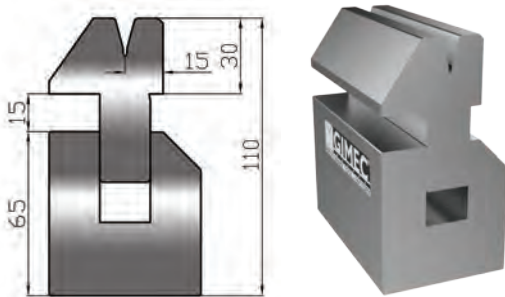

V mm	altezza height	raggio radius	acciaio steel	max kN/mt
8/30°	mm 110-95	1,5	C45 T HRC 52÷58	800
lunghezze - lengths		mm 835 - 415		

**US 308/26° V8**

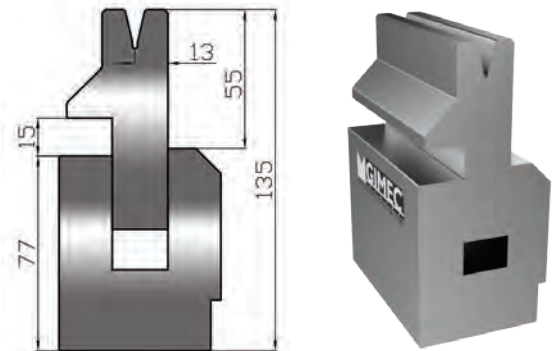

V mm	altezza height	raggio radius	acciaio steel	max kN/mt
8/26°	mm 135-120	1,5	42CM4T HRC52-58	400
lunghezze - lengths		mm 835 - 415		

serie 60®

STANDARD TOOLS

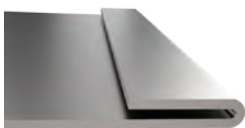

**SPESSORE THICKNESS**

mm	inches
0,6	.024
0,8	.031
1,0	.039
1,2	.047
1,5	.059
2,0	.079
2,5	.098
3,0	.118

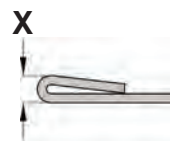

Rm=450 N/mm² Rm=65000 PSI		Rm=700 N/mm² Rm=100000 PSI	
POTENZA POWER			
X mm	inches	kN/mt	US t/ft
3,0	.118	90	3
3,0	.118	120	4
3,5	.137	150	5
3,5	.137	170	6
4,6	.181	220	8
5,5	.216	300	10
6,5	.255	550	18
8,0	.314	700	24

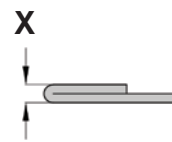

Rm=450 N/mm² Rm=65000 PSI		Rm=700 N/mm² Rm=100000 PSI	
POTENZA POWER			
X mm	inches	kN/mt	US t/ft
1,2	.047	230	8
1,6	.062	320	11
2,0	.078	400	14
2,4	.094	500	17
3,0	.118	630	22
4,0	.157	800	27
5,0	.196	900	31
6,0	.236	1000	34

**US 303/35° V10**

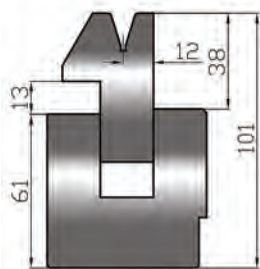

V mm	altezza height	raggio radius	acciaio steel	max kN/mt
10/35°	mm 101-88	1,0	C45 T HRC 52÷58	600
lunghezze - lengths		mm 835 - 415		

**US 302/26° V10**

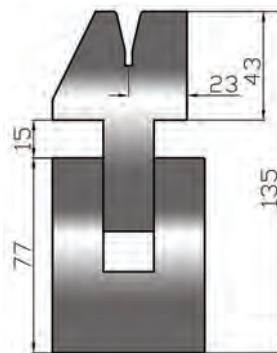

V mm	altezza height	raggio radius	acciaio steel	max kN/mt
10/26°	mm 135-120	1,5	C45 T HRC 52÷58	1000
lunghezze - lengths		mm 835 - 415		

**US 300/26° V12**

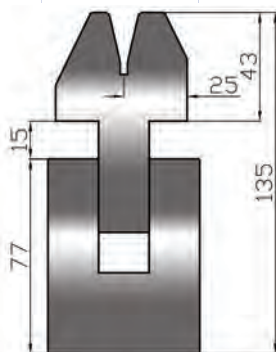

V mm	altezza height	raggio radius	acciaio steel	max kN/mt
12/26°	mm 135-120	2,0	C45 T HRC 52÷58	1000
lunghezze - lengths		mm 835 - 415		

**AVVERTENZE WARNINGS**

Utilizzare queste matrici con utensili superiori con la stessa gradazione.

La tempra viene eseguita sia sulle parti di lavoro che di scorrimento.

Employ these hemming tools with upper tool having the same degree.  
Induction hardened is applied on working surfaces and flowing parts.



**KIT/PNEU**

Gli utensili piegasciaccia serie 300 possono essere forniti con cilindri pneumatici per il sollevamento dell'elemento superiore.

The hemming tools 300 series can be supplied with pneumatic cylinders for moving upper elements.

**US 301 /M(molle-springs) /P(pneumatico-pneumatic)**

**utensili da utilizzare - tools to use**

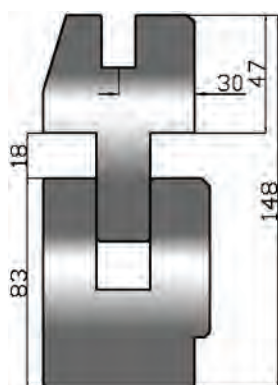

altezza height	acciaio steel	max kN/mt
mm 148-130	42CM4T HRC52-58	1000
lunghezze - lengths		mm 500

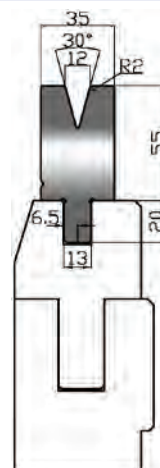
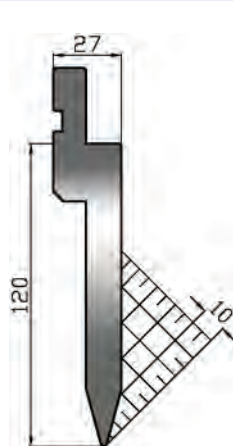

**US 159/30°R1,2**

**USB 55/30°V12P**

**USB 55/30°V14P**

**US 250**

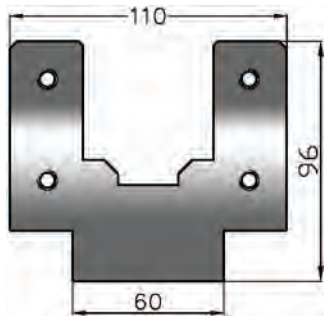

lunghezze-lengths mm 835 - 415

**USG 50**

mm 50x50



82 Shore (giallo-yellow)

lunghezze-lengths mm 835 - 415

**USG 50/F**

mm 50x50



foro/hole  $\varnothing$  mm 25

92 Shore (rosso-red)

lunghezze-lengths mm 835 - 415

**US 275**

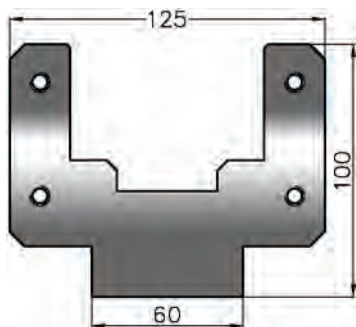

lunghezze-lengths mm 835 - 415

**USG 75**

mm 75x50

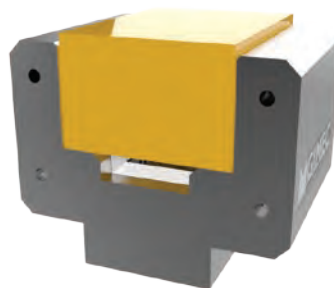

82 Shore (giallo-yellow)

lunghezze-lengths mm 835 - 415

**USG 75/F**

mm 75x50



foro/hole mm 20 X 45

92 Shore (rosso-red)

lunghezze-lengths mm 835 - 415

**US 2100**

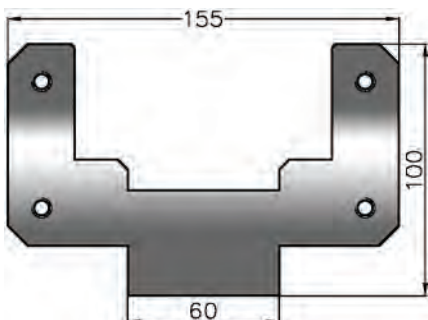

lunghezze-lengths mm 835 - 415

**USG 100**

mm 100x50

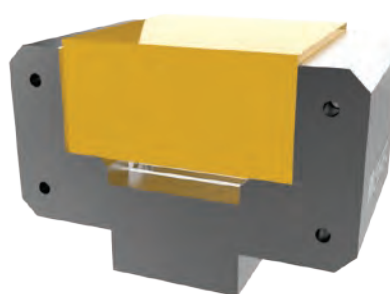

82 Shore (giallo-yellow)

lunghezze-lengths mm 835 - 415

**USG 100/F**

mm 100x50

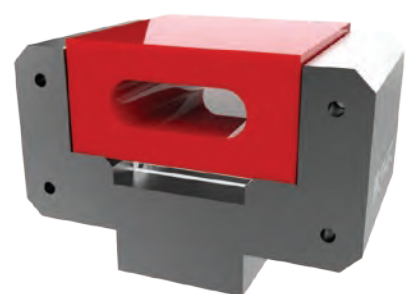

foro/hole mm 20 X 60

92 Shore (rosso-red)

lunghezze-lengths mm 835 - 415

serie 60®

STANDARD TOOLS

**US 220 NYL 14**

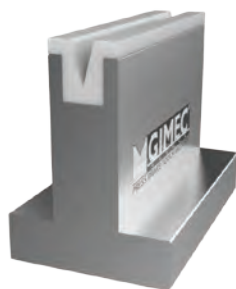
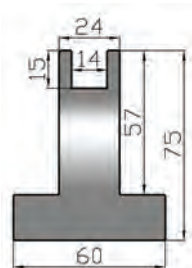

**NYLON 14**

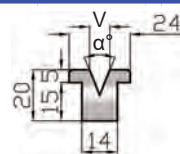

V mm	angolo degree	V mm	angolo degree	V mm	angolo degree
6	88°	8	88°	10	88°
6	60°	8	60°	10	60°
6	45°	8	45°	10	45°
6	30°	8	30°		

lunghezze - lengths

mm 835 - 415

lunghezze - lengths

mm 835 - 415

**US 220 NYL 20**

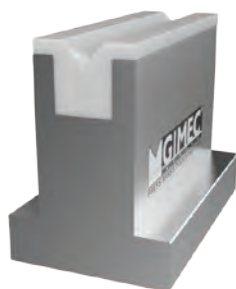
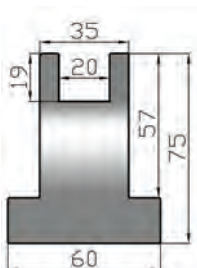

**NYLON 20**

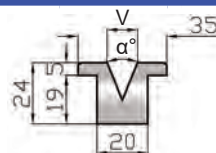

V mm	angolo degree	V mm	angolo degree	V mm	angolo degree
6	88°	8	45°	12	88°
6	60°	8	30°	12	60°
6	45°	10	88°	12	45°
6	30°	10	60°	16	88°
8	88°	10	45°	16	60°
8	60°	10	30°		

lunghezze - lengths

mm 835 - 415

lunghezze - lengths

mm 835 - 415

**US 220 NYL 30**

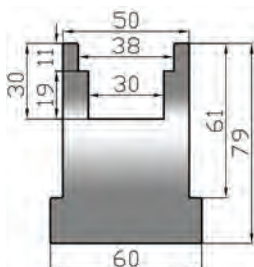

**NYLON 30**

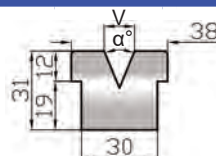

V mm	angolo degree	V mm	angolo degree	V mm	angolo degree
6	88°	10	88°	16	88°
6	60°	10	60°	16	60°
6	45°	10	45°	16	45°
6	30°	10	30°	16	30°
8	88°	12	88°	20	88°
8	60°	12	60°	20	60°
8	45°	12	45°	20	45°
8	30°	12	30°	25	88°

lunghezze - lengths

mm 835 - 415

lunghezze - lengths

mm 835 - 415

serie 60®

STANDARD TOOLS

**US 206/90° V 4 + 7**

max kN/mt 1000

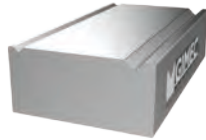
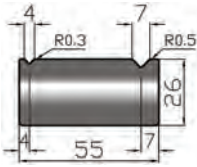

acciaio-steel	C45 T HRC 52-58	lunghezze lengths	mm 835 - 415
---------------	-----------------	-------------------	--------------

**US 212/90° V 6 + 10**

max kN/mt 1000

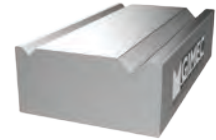
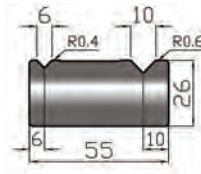

acciaio-steel	C45 T HRC 52-58	lunghezze lengths	mm 835 - 415
---------------	-----------------	-------------------	--------------

**US 213/90° V 8 + 12**

max kN/mt 1000

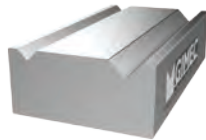
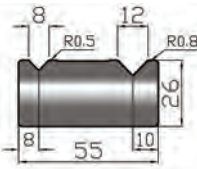

acciaio-steel	C45 T HRC 52-58	lunghezze lengths	mm 835 - 415
---------------	-----------------	-------------------	--------------

**US 212/88° V 6 + 10**

max kN/mt 1000

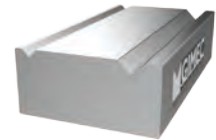
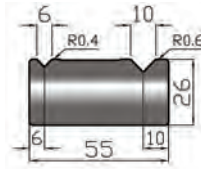

acciaio-steel	C45 T HRC 52-58	lunghezze lengths	mm 835 - 415
---------------	-----------------	-------------------	--------------

**US 213/88° V 8 + 12**

max kN/mt 1000

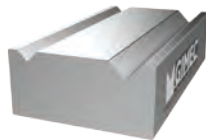
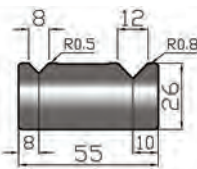

acciaio-steel	C45 T HRC 52-58	lunghezze lengths	mm 835 - 415
---------------	-----------------	-------------------	--------------

**US 207/88° V 14 + 18**

max kN/mt 1000

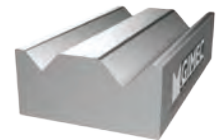
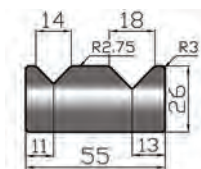

acciaio-steel	C45 T HRC 52-58	lunghezze lengths	mm 835 - 415
---------------	-----------------	-------------------	--------------

**US 214/88° V 12 + 20**

max kN/mt 1000

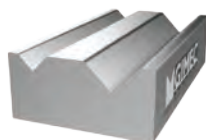
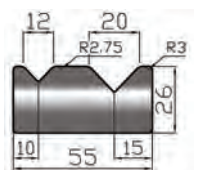

acciaio-steel	C45 T HRC 52-58	lunghezze lengths	mm 835 - 415
---------------	-----------------	-------------------	--------------

**US 215/88° V 16 + 25**

max kN/mt 1000

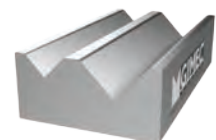
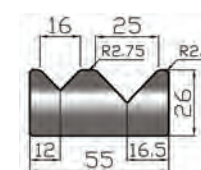

acciaio-steel	C45 T HRC 52-58	lunghezze lengths	mm 835 - 415
---------------	-----------------	-------------------	--------------

serie 60®

STANDARD TOOLS



**US 218/60° V 6 + 10**

max kN/mt 600

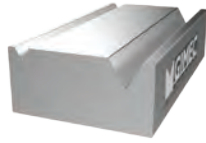
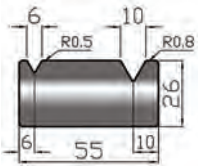

**US 219/60° V 8 + 12**

max kN/mt 800

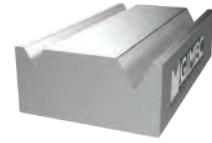
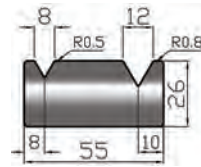

acciaio-steel

C45 T HRC  
52÷58

lunghezze  
lengths

mm 835 - 415

acciaio-steel

C45 T HRC  
52÷58

lunghezze  
lengths

mm 835 - 415

**US 221/60° V 12 + 20**

max kN/mt 800

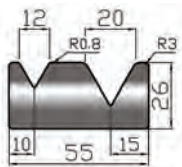

**US 222/60° V 16 + 20**

max kN/mt 800

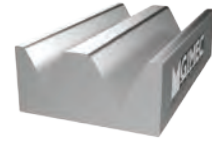
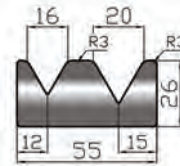

acciaio-steel

C45 T HRC  
52÷58

lunghezze  
lengths

mm 835 - 415

acciaio-steel

C45 T HRC  
52÷58

lunghezze  
lengths

mm 835 - 415

**US 223/35° V 6 + 10**

max kN/mt 300

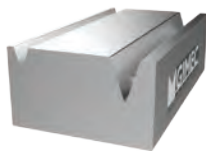
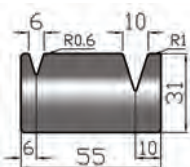

**US 224/35° V 8 + 12**

max kN/mt 300

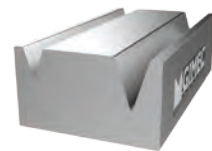
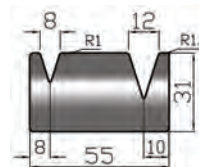

acciaio-steel

C45 T HRC  
52÷58

lunghezze  
lengths

mm 835 - 415

acciaio-steel

C45 T HRC  
52÷58

lunghezze  
lengths

mm 835 - 415

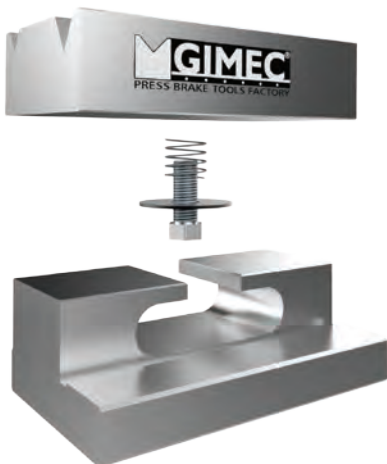

**US 406/34**

**US 407/55**

**US 408/75**

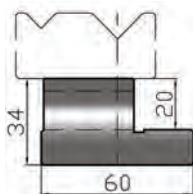

altezza - height mm 34

altezza - height mm 55

altezza - height mm 75

lunghezze - lengths

mm 830 - 410

**US 510/90° V 4 + 7**

max kN/mt 800

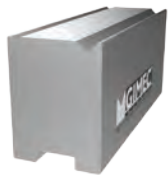
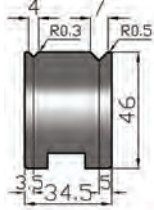

acciaio-steel  
C45 T HRC 52÷58

lunghezze-lengths  
mm 835 - 415

**US 520/90° V 6 + 10**

max kN/mt 800

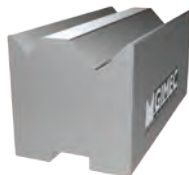
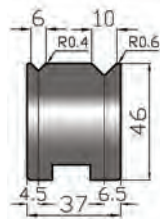

acciaio-steel  
C45 T HRC 52÷58

lunghezze-lengths  
mm 835 - 415

**US 530/90° V 8 + 12**

max kN/mt 800

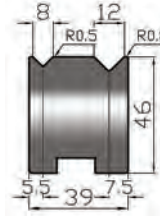

acciaio-steel  
C45 T HRC 52÷58

lunghezze-lengths  
mm 835 - 415

**US 540/88° V 8 + 12**

max kN/mt 800

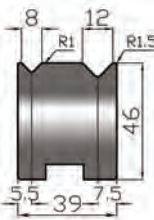

acciaio-steel  
C45 T HRC 52÷58

lunghezze-lengths  
mm 835 - 415

**US 550/88° V 14 + 18**

max kN/mt 800

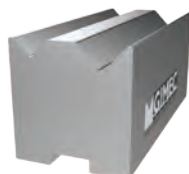
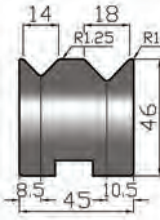

acciaio-steel  
C45 T HRC 52÷58

lunghezze-lengths  
mm 835 - 415

**US 560/88° V 12 + 20**

max kN/mt 800

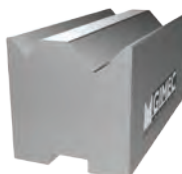
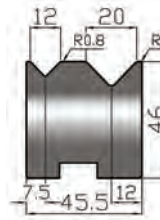

acciaio-steel  
C45 T HRC 52÷58

lunghezze-lengths  
mm 835 - 415

**US 570/88° V 16 + 25**

max kN/mt 800

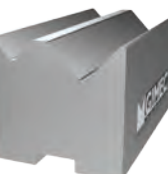
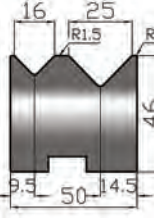

acciaio-steel  
C45 T HRC 52÷58

lunghezze-lengths  
mm 835 - 415

**US 580/30° V 6 + 10**

max kN/mt 400

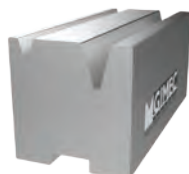
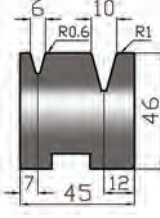

acciaio-steel  
C45 T HRC 52÷58

lunghezze-lengths  
mm 835 - 415

**US 590/30° V 8 + 12**

max kN/mt 400

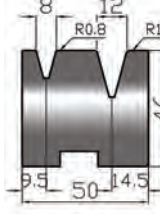

acciaio-steel  
C45 T HRC 52÷58

lunghezze-lengths  
mm 835 - 415

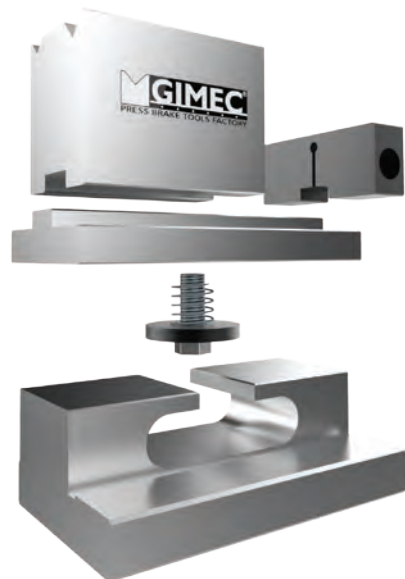

**US 500**

**US 501**

**US 505**

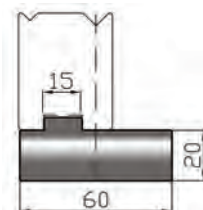
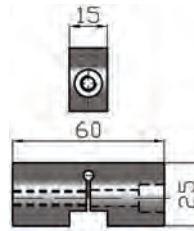
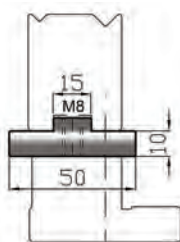

altezza - height mm 34

altezza - height mm 75

lunghezze - lengths

mm 835 - 415

serie 60®

STANDARD TOOLS

**US 600**

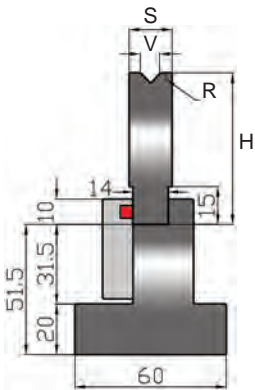

88°	V mm	H mm	R mm	S mm	max kN/mt
US 604/88°	4	60	0,60	14	1000
US 606/88°	6	60	0,80	14	1000
US 608/88°	8	60	1,00	14	1000
US 610/88°	10	60	1,20	18	1000
US 612/88°	12	60	1,50	18	1000
US 616/88°	16	60	2,00	24	1000
US 620/88°	20	60	2,00	30	1000
US 625/88°	25	60	3,00	35	1000

30°	V mm	H mm	R mm	S mm	max kN/mt
US 606/30°	6	60	0,60	14	350
US 608/30°	8	60	0,80	18	350
US 610/30°	10	60	1,00	24	500
US 612/30°	12	60	1,50	24	400
US 616/30°	16	60	2,00	30	450
US 620/30°	20	60	2,50	35	500
US 625/30°	25	65	3,00	45	500

lunghezze - lengths  
mm 835 - 415 - fraz

acciaio - steel  
C45 T HRC 52÷58

**US 700 - MATRICI A RULLI - ROLLER DIES**

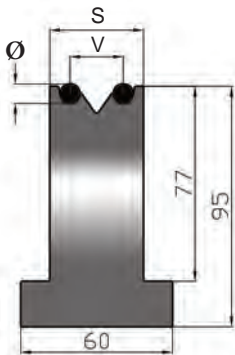

70°78°30°	V mm	Ø mm	S mm	max kN/mt
US 706/70°	6	6	25	800
US 708/70°	8	6	26	800
US 710/70°	10	6	27	800
US 712/70°	12	6	29	800
US 716/70°	16	8	37	1000
US 720/70°	20	8	42	1000
US 725/70°	25	8	48	1000
US 730/70°	30	8	60	1000
US 740/78°	40	10	72	1100

70°78°30°	V mm	Ø mm	S mm	max kN/mt
US 750/78°	50	10	82	1200
US 760/78°	60	12	102	1300
US 780/78°	80	16	132	1400
US 706/30°	6	6	25	500
US 708/30°	8	6	26	500
US 710/30°	10	6	27	500
US 712/30°	12	6	29	500
US 716/30°	16	8	40	500
US 720/30°	20	8	44	500

lunghezze - lengths  
mm 835 - 415 - fraz

acciaio - steel  
C45 T HRC 52÷58

**ATTACCHI SPECIALI - SPECIAL CLAMPINGS**



Z13

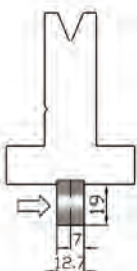

Z12,7

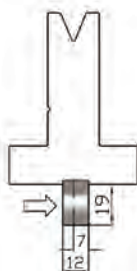

Z12

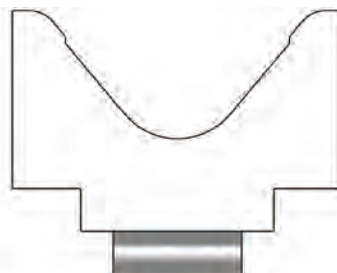

Z60 mm 60  
Z90 mm 90

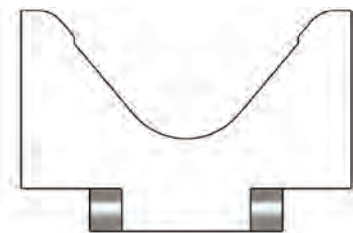

MODIFICA  
MODIFICATION

**LUNGHEZZE - LENGTHS**

mm 835 - 415 - 805 fraz 10+15+20+40+50+100+200+370

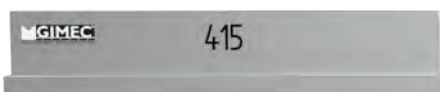

415



835



10 15 20 40 50



100 200



370

**UST 135 S / 60° R3,0** tipo-like **BIU-004**

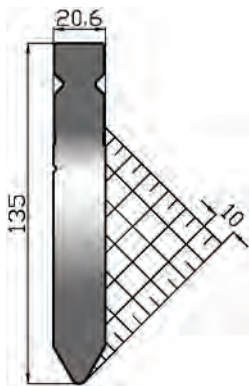

altezza height mm	angolo degree	raggio radius	acciaio steel	max kN/mt
135,0	60°	3,0	42CM4 T HRC 52-58	1600
lunghezze - lengths		mm 515 - fraz L 550 W		

**UST 135 X / 28° R1,0** tipo-like **BIU-001**

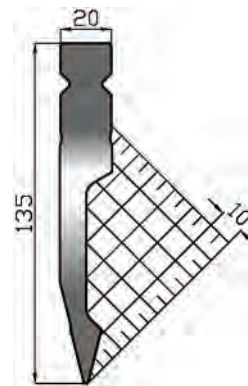

altezza height mm	angolo degree	raggio radius	acciaio steel	max kN/mt
135,0	28°	1,0	42CM4 T HRC 52-58	1000
lunghezze - lengths		mm 515 - fraz L 550 W		

**UST 157 S / 60° R4,0**

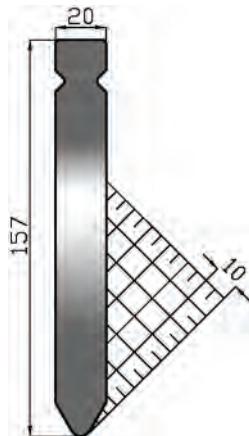

altezza height mm	angolo degree	raggio radius	acciaio steel	max kN/mt
157,0	60°	4,0	42CM4 T HRC 52-58	1300
lunghezze - lengths		mm 500 - L 550 (1A)		

**UST 157 X / 28° R1,0** tipo-like **BIU-011**

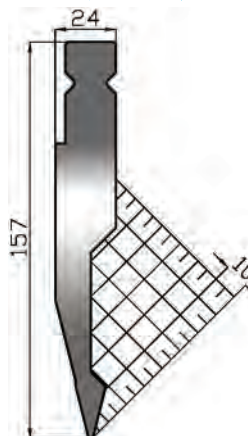

altezza height mm	angolo degree	raggio radius	acciaio steel	max kN/mt
157,0	28°	1,0	42CM4 T HRC 52-58	600
lunghezze - lengths		mm 500 - L 550 (1A)		



serie **UST**®

STANDARD TOOLS

**UST 135 D / 80° R1,0** tipo-like BIU-002

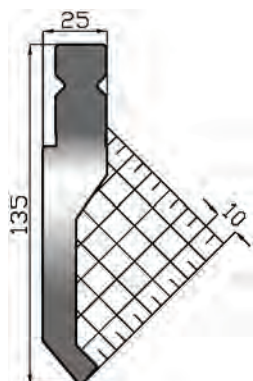

altezza height mm	angolo degree	raggio radius	acciaio steel	max kN/mt
135,0	80°	1,0	42CM4 T HRC 52-58	1000
lunghezze - lengths		mm 515 - fraz L 550 W		

**UST 135 C / 86° R1,0** tipo-like BIU-003

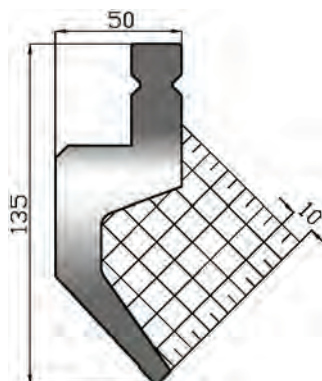

altezza height mm	angolo degree	raggio radius	acciaio steel	max kN/mt
135,0	86°	1,0	42CM4 T HRC 52-58	650
lunghezze - lengths		mm 515 - fraz L 550 W		

**UST 157 D / 86° R1,0** tipo-like BIU-012

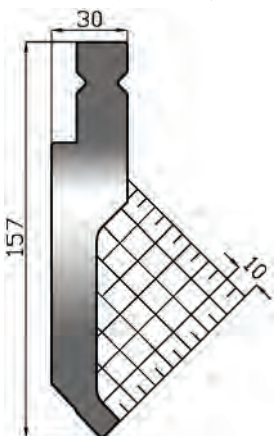

altezza height mm	angolo degree	raggio radius	acciaio steel	max kN/mt
157,0	86°	1,0	42CM4 T HRC 52-58	800
lunghezze - lengths		mm 500 - L 550 (1A)		

**UST 157 C / 60° R1,0**

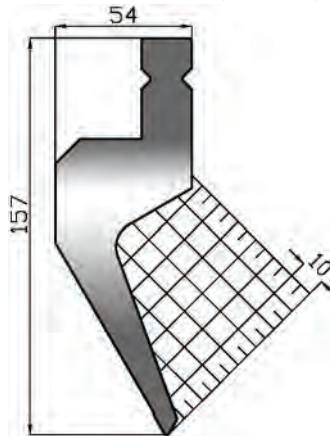

altezza height mm	angolo degree	raggio radius	acciaio steel	max kN/mt
157,0	60°	1,0	42CM4 T HRC 52-58	700
lunghezze - lengths		mm 500 - L 550 (1A)		

**UST 157 C / 86° R1,0** tipo-like BIU-013

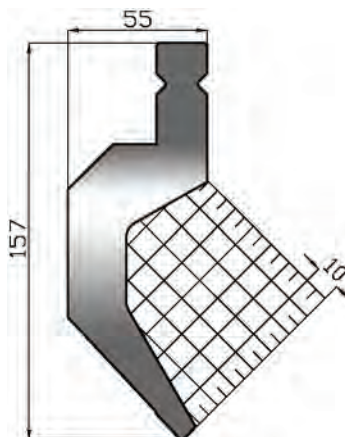

altezza height mm	angolo degree	raggio radius	acciaio steel	max kN/mt
157,0	86°	1,0	42CM4 T HRC 52-58	800
lunghezze - lengths		mm 500 - L 550 (1A)		

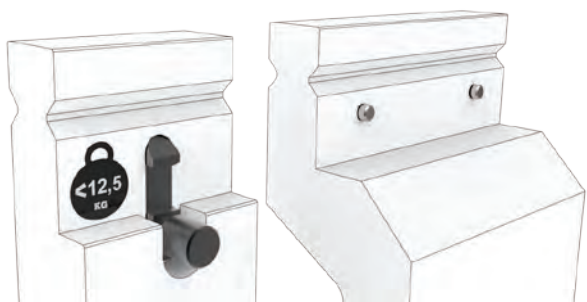

Gli utensili con peso inferiore a 12,5 kg vengono forniti con singolo o doppio pulsante. Oltre tale peso l'utensile viene fornito con spine.  
Tools with a weight less than 12,5 kg are supplied with a single or double push buttons. Beyond such weight the tool is supplied with pins.

serie UST®

STANDARD TOOLS

**UST 195 S / 26° R0,8**

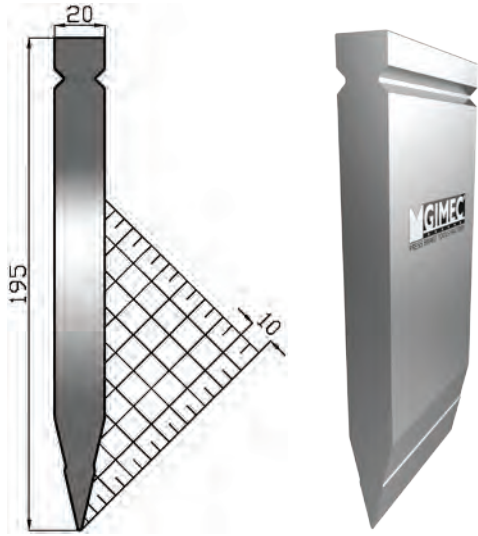

**UST 195 S / 28° R3,0**

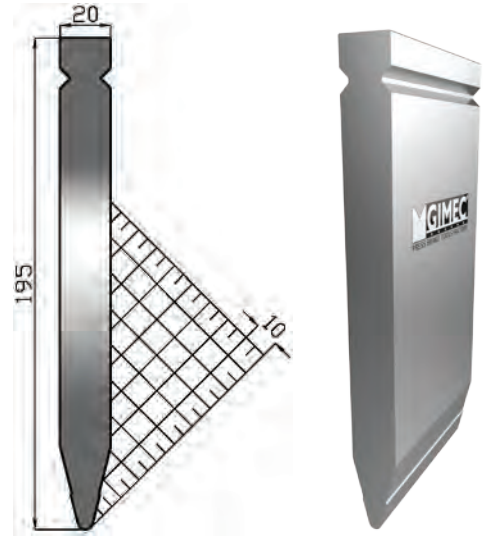

altezza height mm	angolo degree	raggio radius	acciaio steel	max kN/mt
195,0	26°	0,8	42CM4 T HRC 52-58	1000
lunghezze - lengths			mm 500 - fraz L 550 (P)	

altezza height mm	angolo degree	raggio radius	acciaio steel	max kN/mt
195,0	28°	3,0	42CM4 T HRC 52-58	1000
lunghezze - lengths			mm 500 - fraz L 550 (P)	

serie UST®

STANDARD TOOLS

**UST 195 X / 28° R1,0**

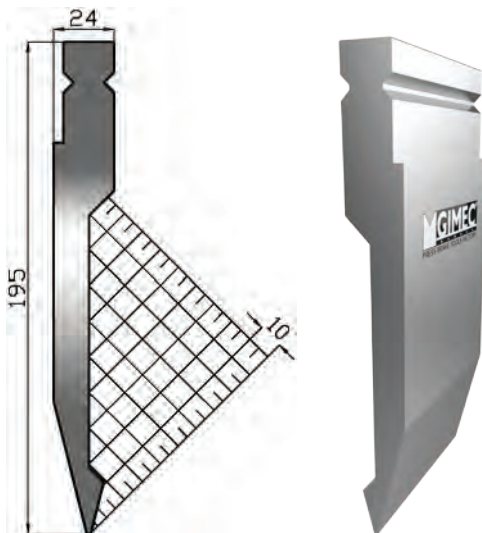

altezza height mm	angolo degree	raggio radius	acciaio steel	max kN/mt
195,0	28°	1,0	42CM4 T HRC 52-58	800
lunghezze - lengths			mm 500 - fraz L 550 (P)	

**UST 195 D / 86° R0,6**

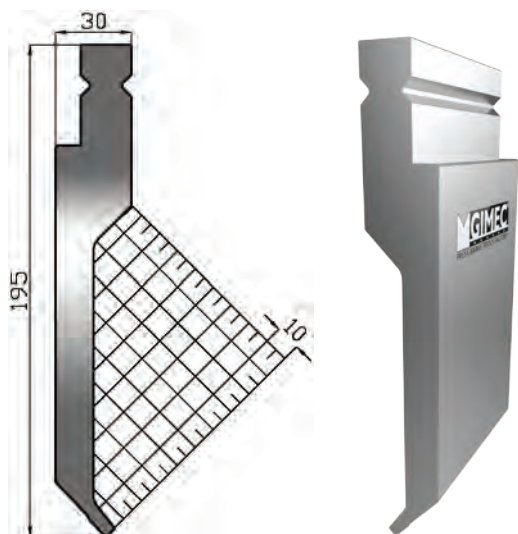

altezza height mm	angolo degree	raggio radius	acciaio steel	max kN/mt
195,0	86°	0,6	42CM4 T HRC 52-58	300
lunghezze - lengths		mm 500 - fraz L 550 (P)		

**UST 195 D / 86° R0,8**

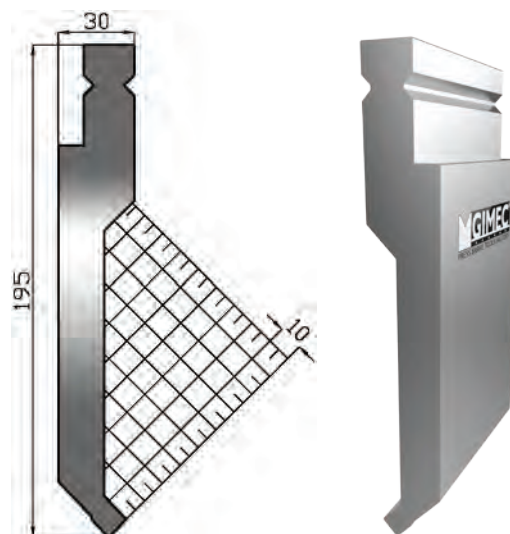

altezza height mm	angolo degree	raggio radius	acciaio steel	max kN/mt
195,0	86°	0,8	42CM4 T HRC 52-58	1000
lunghezze - lengths		mm 500 - fraz L 550 (P)		

**UST 195 C / 60° R0,8**

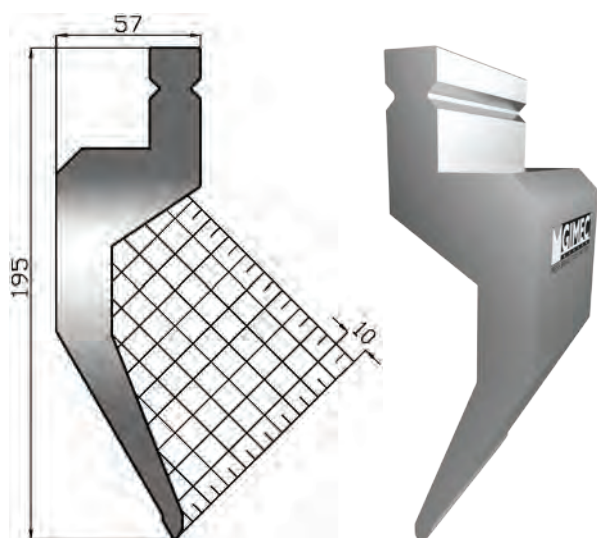

altezza height mm	angolo degree	raggio radius	acciaio steel	max kN/mt
195,0	60°	0,8	42CM4 T HRC 52-58	400
lunghezze - lengths		mm 500 - fraz L 550 (P)		

**UST 195 C / 86° R0,8**

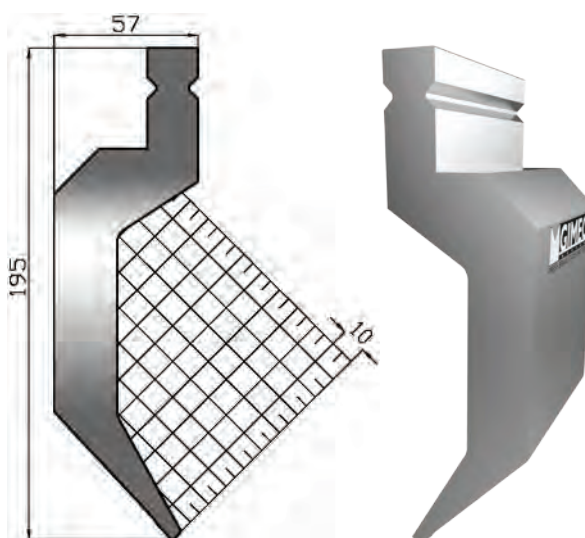

altezza height mm	angolo degree	raggio radius	acciaio steel	max kN/mt
195,0	86°	0,8	42CM4 T HRC 52-58	400
lunghezze - lengths		mm 500 - fraz L 550 (P)		

serie UST®

STANDARD TOOLS

**UST 200 S / 28° R3,0**

tipo-like BIU-029

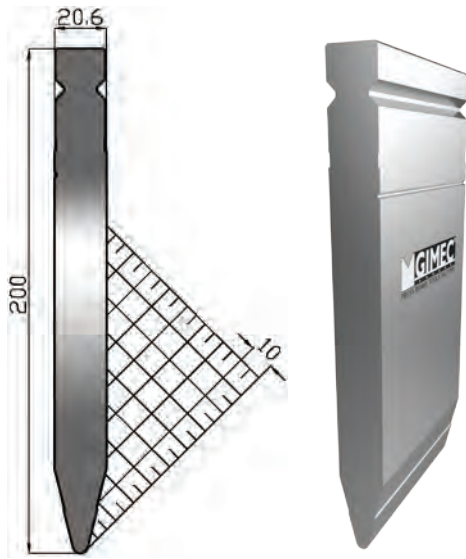

altezza height mm	angolo degree	raggio radius	acciaio steel	max kN/mt
200,0	28°	3,0	42CM4 T HRC 52÷58	1600
lunghezze - lengths		mm 515 - fraz L 550 W		

**UST 200 S / 60° R6,0**

tipo-like BIU-222

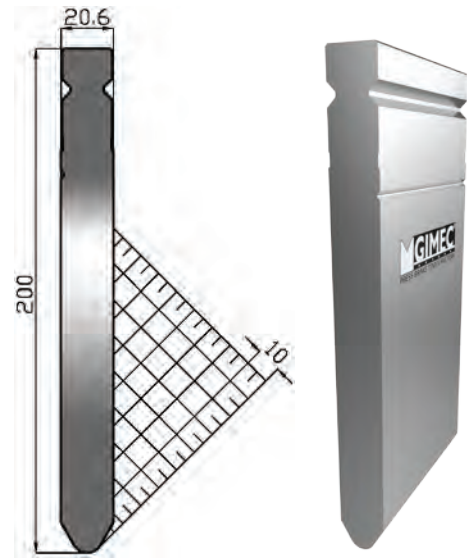

altezza height mm	angolo degree	raggio radius	acciaio steel	max kN/mt
200,0	60°	6,0	42CM4 T HRC 52÷58	1600
lunghezze - lengths		mm 515 - fraz L 550 W		

**UST 200 S / 60° R12,5**

tipo-like BIU-223

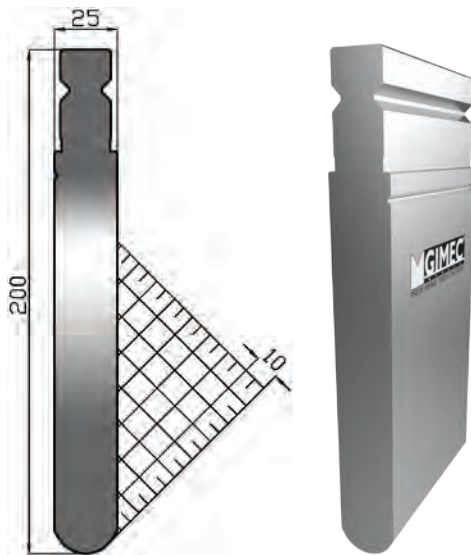

altezza height mm	angolo degree	raggio radius	acciaio steel	max kN/mt
200,0	60°	12,5	42CM4 T HRC 52÷58	2250
lunghezze - lengths		mm 515 - fraz L 550 W		

**UST 200 X / 26° R0,8**

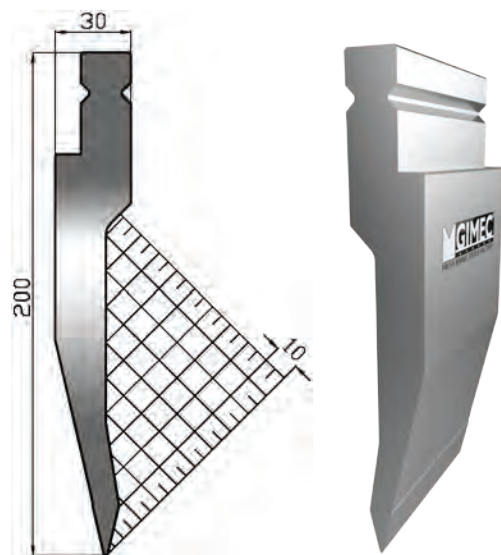

altezza height mm	angolo degree	raggio radius	acciaio steel	max kN/mt
200,0	26°	0,8	42CM4 T HRC 52÷58	700
lunghezze - lengths		mm 515 - fraz L 550 (2)		

serie UST®

STANDARD TOOLS



**UST 200 X / 28° R1,0**

tipo-like BIU-021

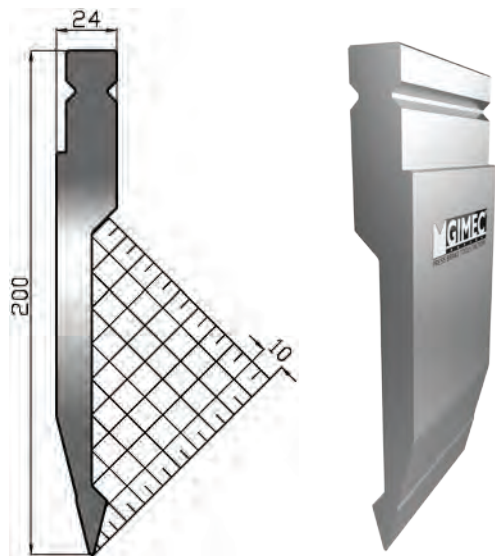

altezza height mm	angolo degree	raggio radius	acciaio steel	max kN/mt
200,0	28°	1,0	42CM4 T HRC 52-58	700
lunghezze - lengths		mm 515 - fraz L 550 (2)		

**UST 200 X / 28° R3,0**

tipo-like BIU-221

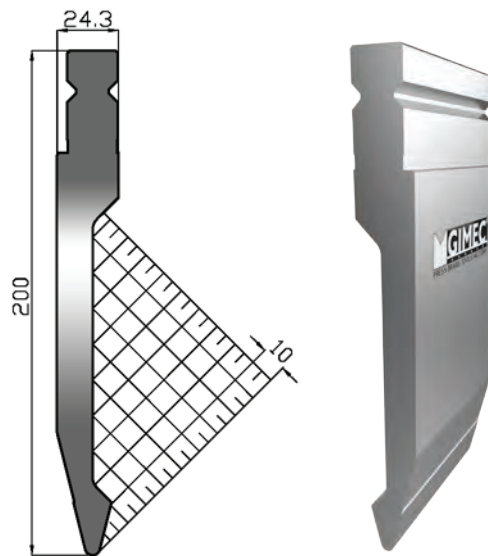

altezza height mm	angolo degree	raggio radius	acciaio steel	max kN/mt
200,0	28°	3,0	42CM4 T HRC 52-58	1000
lunghezze - lengths		mm 515 - fraz L 550 W		

**UST 200 D / 86° R0,6**

tipo-like BIU-224

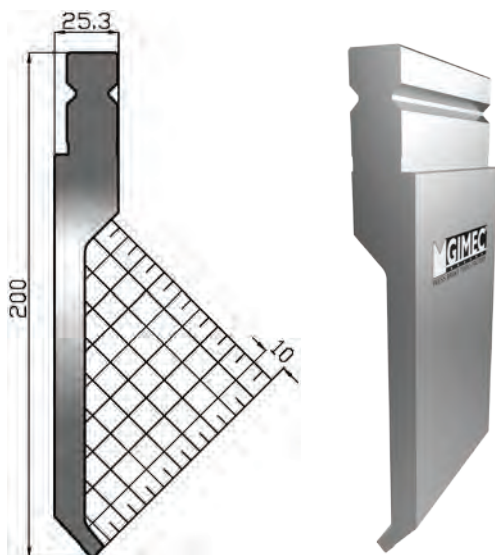

altezza height mm	angolo degree	raggio radius	acciaio steel	max kN/mt
200,0	86°	0,6	42CM4 T HRC 52-58	450
lunghezze - lengths		mm 515 - fraz L 550 W		

**UST 200 D / 80° R1,0**

tipo-like BIU-022

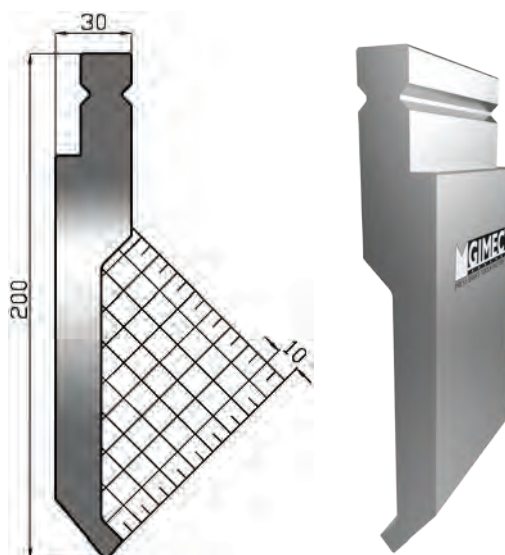

altezza height mm	angolo degree	raggio radius	acciaio steel	max kN/mt
200,0	80°	1,0	42CM4 T HRC 52-58	800
lunghezze - lengths		mm 515 - fraz L 550 (2)		

serie UST®

STANDARD TOOLS

**UST 200 DP / 80° R3,0** tipo-like BIU-026

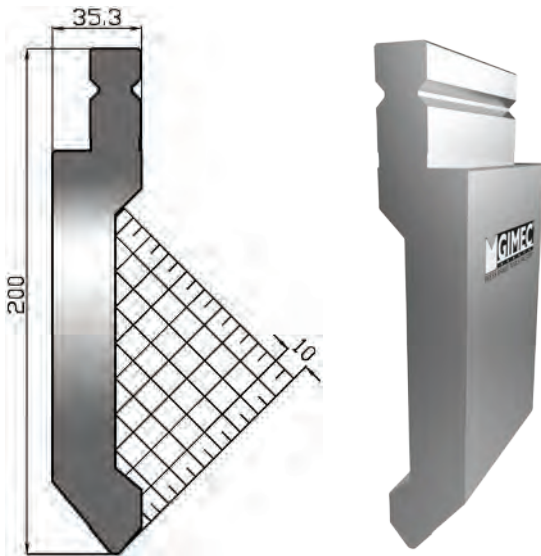

altezza height mm	angolo degree	raggio radius	acciaio steel	max kN/mt
200,0	80°	3,0	42CM4 T HRC 52-58	1400
lunghezze - lengths		mm 515 - fraz L 550 W		

**UST 200 C / 45° R1,0** tipo-like BIU-226

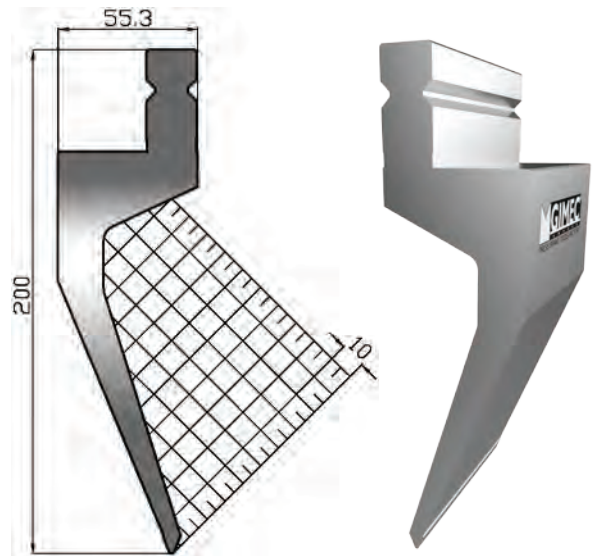

altezza height mm	angolo degree	raggio radius	acciaio steel	max kN/mt
200,0	45°	1,0	42CM4 T HRC 52-58	400
lunghezze - lengths		mm 515 - fraz L 550 W		

**UST 200 C / 60° R1,0**

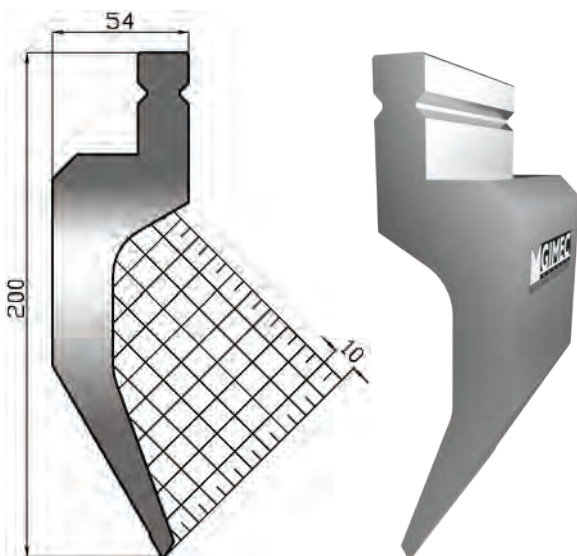

altezza height mm	angolo degree	raggio radius	acciaio steel	max kN/mt
200,0	60°	1,0	42CM4 T HRC 52-58	700
lunghezze - lengths		mm 515 - fraz L 550 (2)		

**UST 200 C / 86° R1,0** tipo-like BIU-023

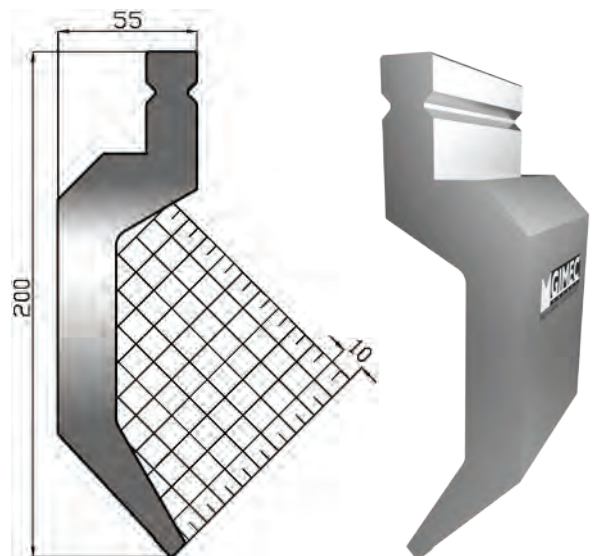

altezza height mm	angolo degree	raggio radius	acciaio steel	max kN/mt
200,0	86°	1,0	42CM4 T HRC 52-58	650
lunghezze - lengths		mm 515 - fraz L 550 (2)		

serie UST®

STANDARD TOOLS

**UST 200 CS / 85° R0,8**

**UST 200 C / 85° R0,8**

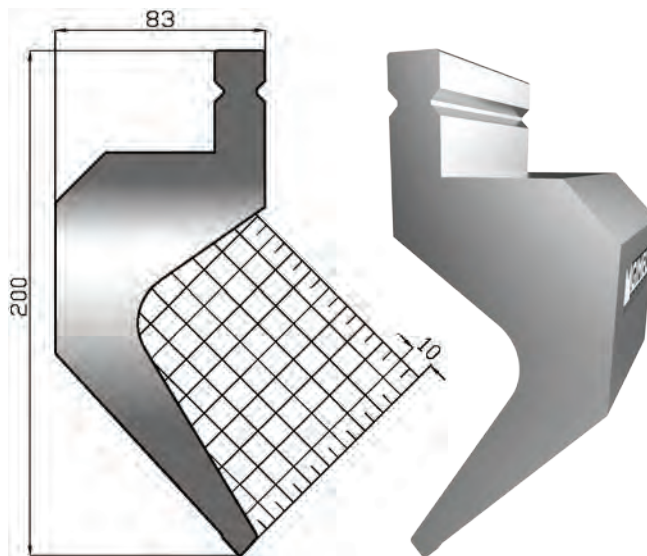
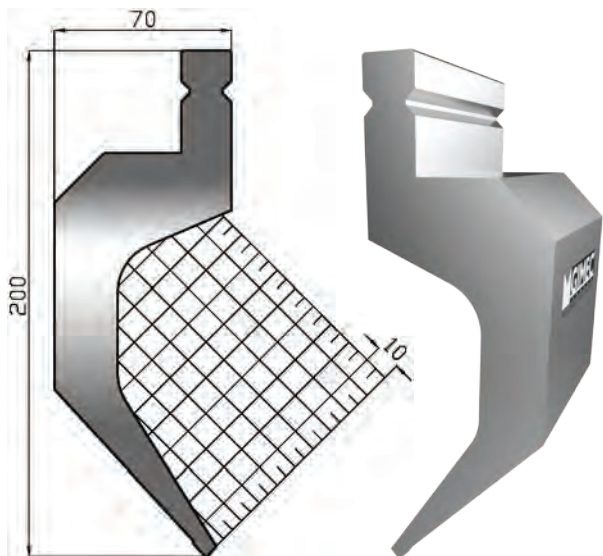

altezza height mm	angolo degree	raggio radius	acciaio steel	max kN/mt
200,0	85°	0,8	42CM4 T HRC 52÷58	600
lunghezze - lengths		mm 515 - fraz L 550 (2)		

altezza height mm	angolo degree	raggio radius	acciaio steel	max kN/mt
200,0	85°	0,8	42CM4 T HRC 52÷58	800
lunghezze - lengths		mm 515 - fraz L 550 (2)		

**UST 200 CP / 80° R3,0** tipo-like BIU-225

**UST 200 CP / 80° R6,0** tipo-like BIU-025

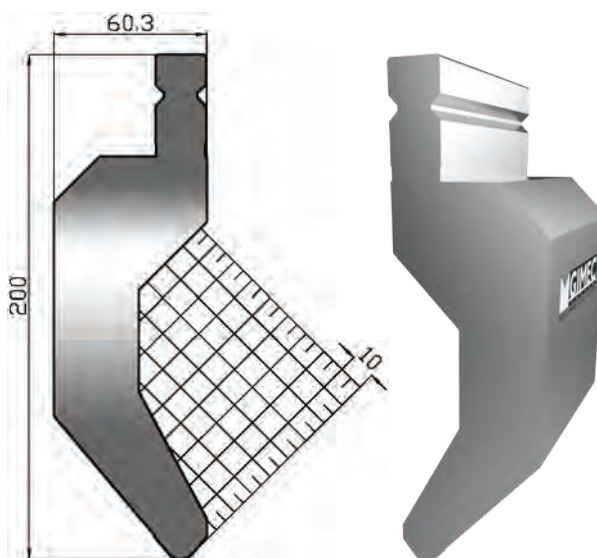
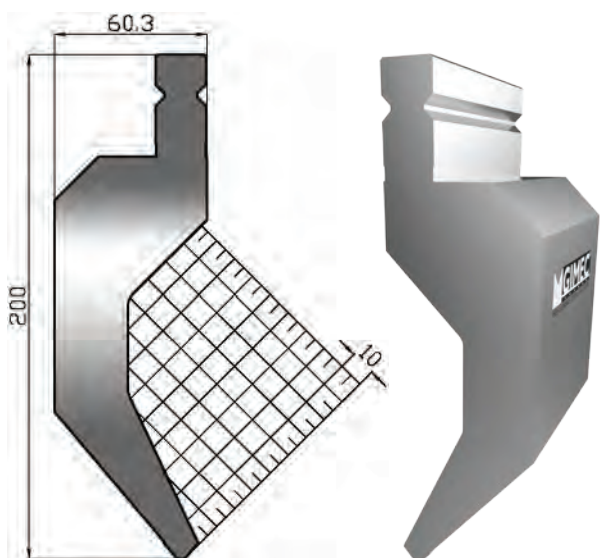

altezza height mm	angolo degree	raggio radius	acciaio steel	max kN/mt
200,0	80°	3,0	42CM4 T HRC 52÷58	900
lunghezze - lengths		mm 515 - fraz L 550 W		

altezza height mm	angolo degree	raggio radius	acciaio steel	max kN/mt
200,0	80°	6,0	42CM4 T HRC 52÷58	1300
lunghezze - lengths		mm 515 - fraz L 550 W		

serie UST®

STANDARD TOOLS

**UST 237 S / 60° R3,0**

tipo-like BIU-034

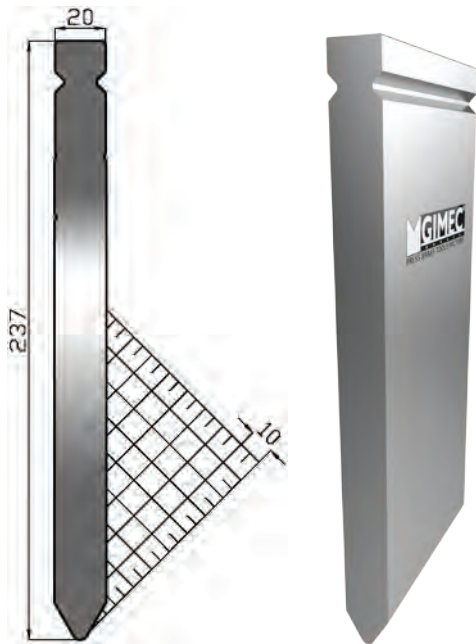

altezza height mm	angolo degree	raggio radius	acciaio steel	max kN/mt
237,0	60°	3,0	42CM4 T HRC 52±58	1600
lunghezze - lengths			mm 515 - fraz L 550 (2)	

**UST 237 S / 60° R6,0**

tipo-like BIU-037

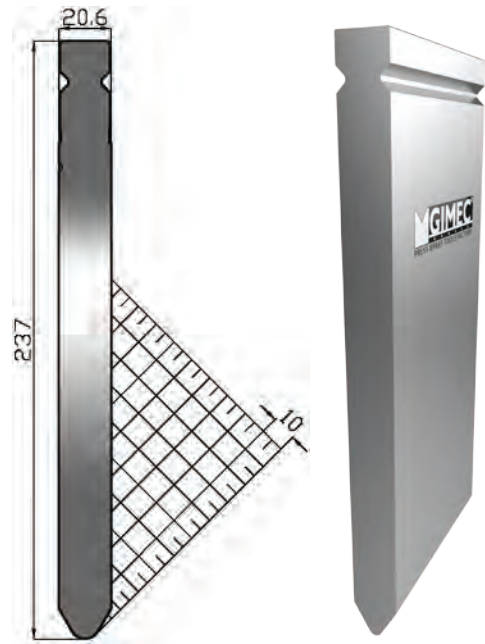

altezza height mm	angolo degree	raggio radius	acciaio steel	max kN/mt
237,0	60°	6,0	42CM4 T HRC 52±58	1600
lunghezze - lengths			mm 515 - fraz L 550 W	

**UST 237 S / 60° R12,5**

tipo-like BIU-038

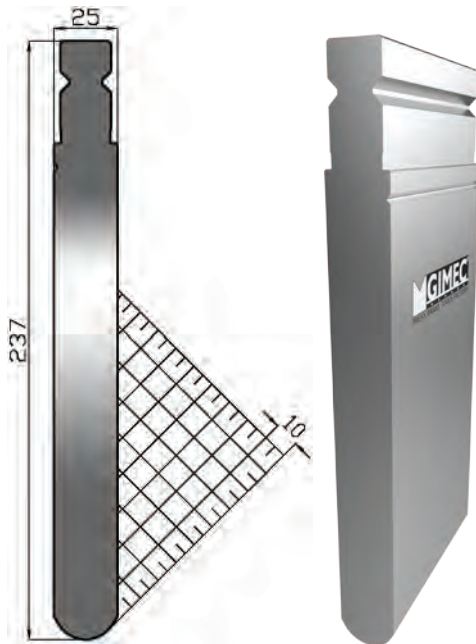

altezza height mm	angolo degree	raggio radius	acciaio steel	max kN/mt
237,0	60°	12,5	42CM4 T HRC 52±58	2250
lunghezze - lengths			mm 515 - fraz L 550 W	

**UST 237 X / 26° R0,8**

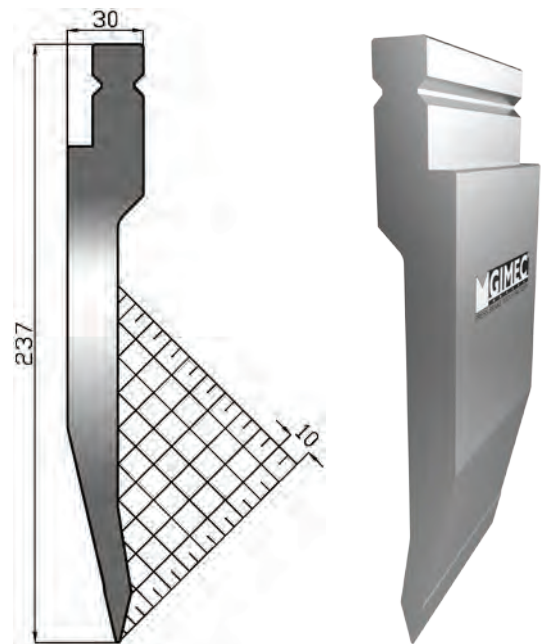

altezza height mm	angolo degree	raggio radius	acciaio steel	max kN/mt
237,0	26°	0,8	42CM4 T HRC 52±58	1000
lunghezze - lengths			mm 500-fraz C250 - L550 (2)	

serie UST®

STANDARD TOOLS

**UST 237 X / 28° R1,0** tipo-like BIU-031

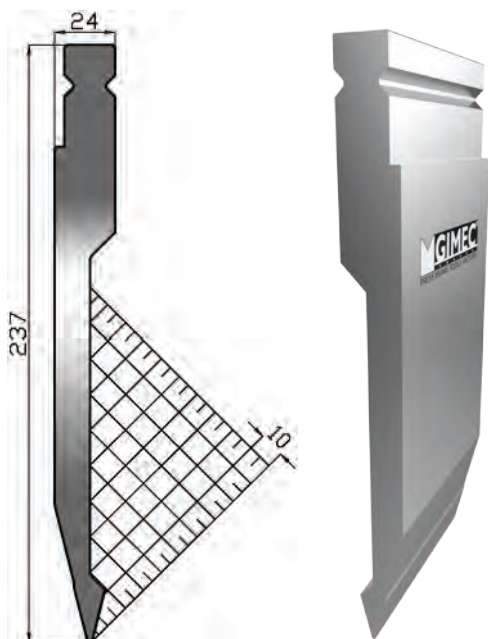

altezza height mm	angolo degree	raggio radius	acciaio steel	max kN/mt
237,0	28°	1,0	42CM4 T HRC 52÷58	600
lunghezze - lengths		mm 515 - fraz L 550 (2)		

**UST 237 X / 28° R3,0** tipo-like BIU-231

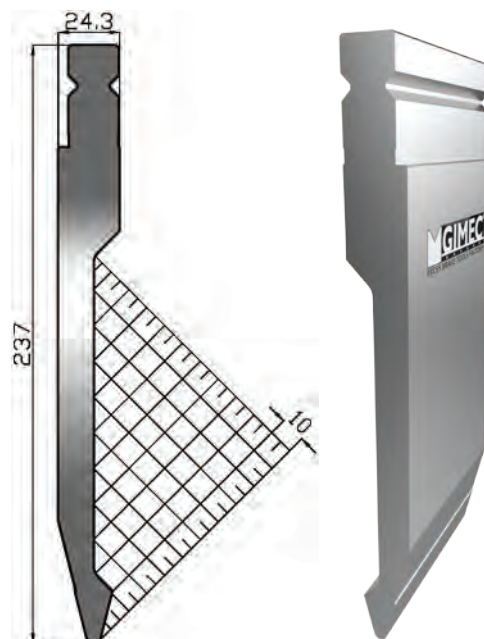

altezza height mm	angolo degree	raggio radius	acciaio steel	max kN/mt
237,0	28°	3,0	42CM4 T HRC 52÷58	1000
lunghezze - lengths		mm 515 - fraz L 550 W		

**UST 237 D / 90° R0,6** tipo-like BIU-035

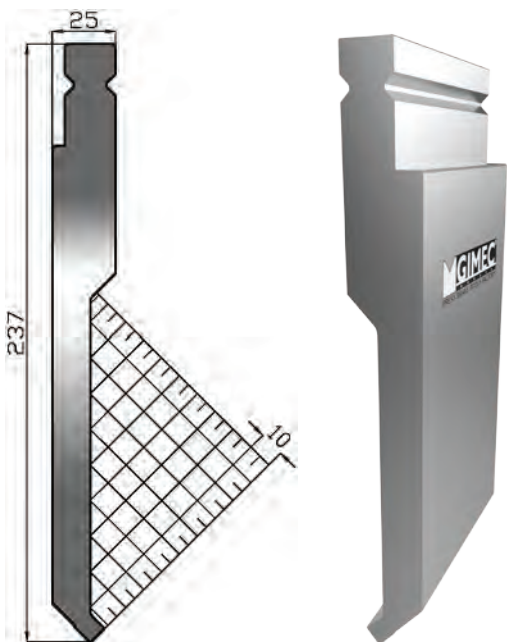

altezza height mm	angolo degree	raggio radius	acciaio steel	max kN/mt
237,0	90°	0,6	42CM4 T HRC 52÷58	600
lunghezze - lengths		mm 515 - fraz L 550 (2)		

**UST 237 D / 80° R1,0** tipo-like BIU-032

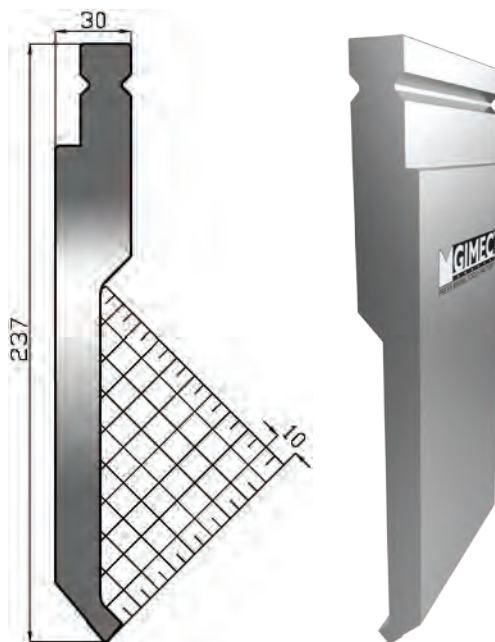

altezza height mm	angolo degree	raggio radius	acciaio steel	max kN/mt
237,0	80°	1,0	42CM4 T HRC 52÷58	800
lunghezze - lengths		mm 515 - fraz L 550 (2)		

serie UST®

STANDARD TOOLS

serie UST®

STANDARD TOOLS

**UST 237 C / 60° R1,0**

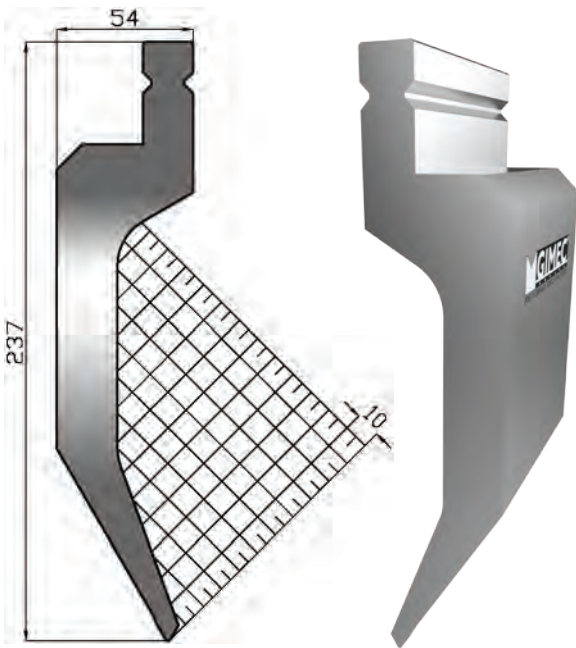

altezza height mm	angolo degree	raggio radius	acciaio steel	max kN/mt
237,0	60°	1,0	42CM4 T HRC 52-58	700
lunghezze - lengths		mm 515 - fraz L 550 (2)		

**UST 237 C / 86° R1,0** tipo-like BIU-033

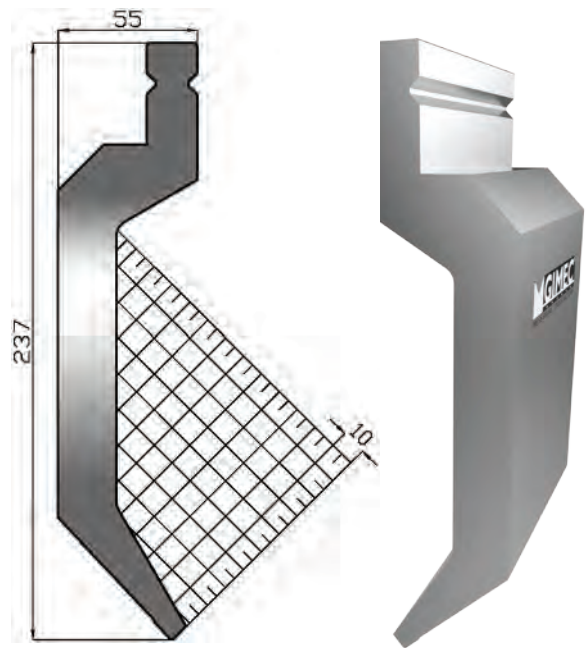

altezza height mm	angolo degree	raggio radius	acciaio steel	max kN/mt
237,0	86°	1,0	42CM4 T HRC 52-58	500
lunghezze - lengths		mm 515 - fraz L 550 (2)		

**UST 237 CP / 80° R3,0** tipo-like BIU-233

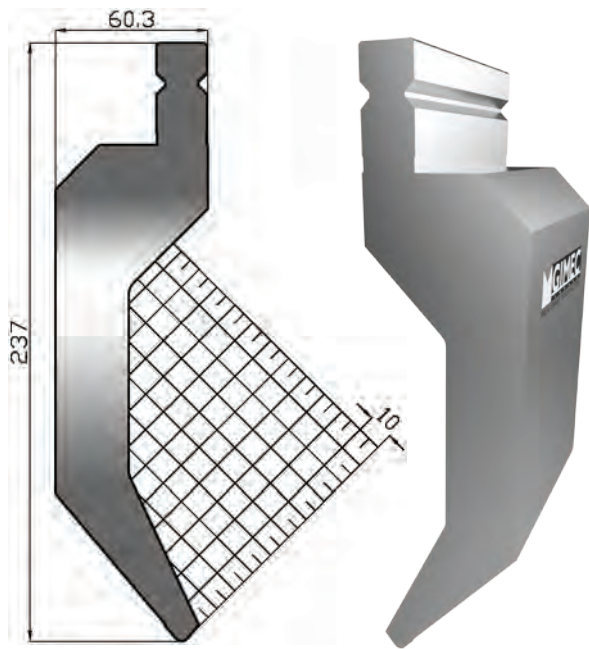

altezza height mm	angolo degree	raggio radius	acciaio steel	max kN/mt
237,0	80°	3,0	42CM4 T HRC 52-58	900
lunghezze - lengths		mm 515 - fraz L 550 W		

**UST 237 CP / 80° R6,0** tipo-like BIU-235

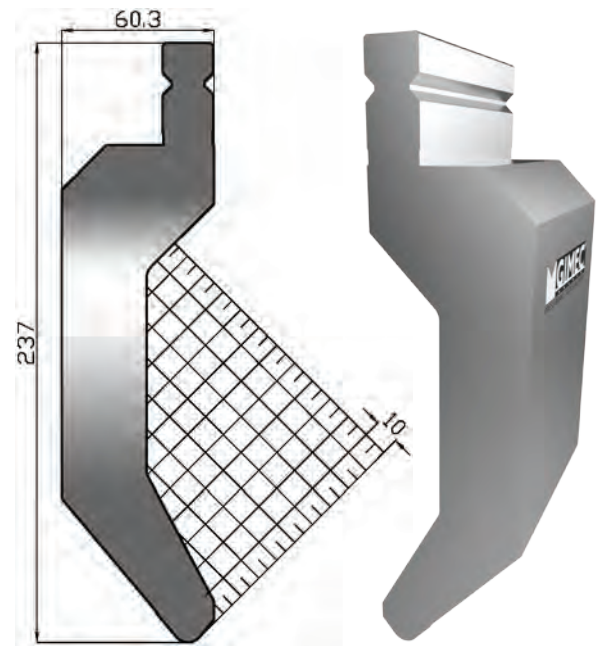

altezza height mm	angolo degree	raggio radius	acciaio steel	max kN/mt
237,0	80°	6,0	42CM4 T HRC 52-58	1300
lunghezze - lengths		mm 515 - fraz L 550 W		

**UST 237 C / 85° R0,8**

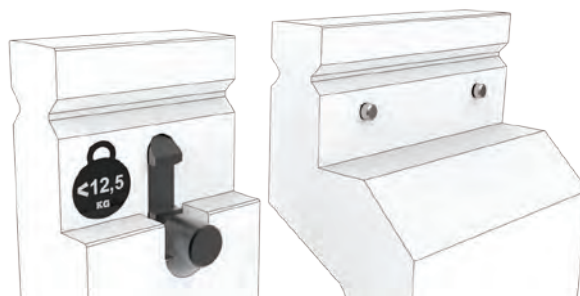
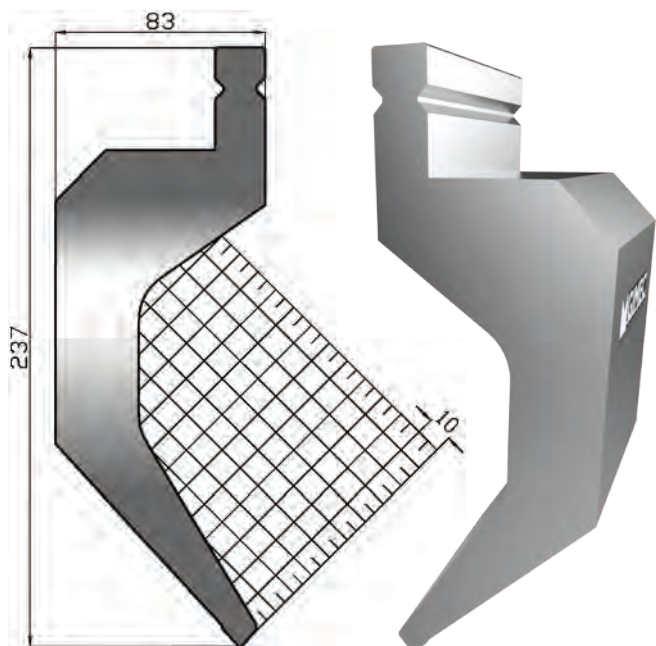

Gli utensili con peso inferiore a 12,5 kg vengono forniti con singolo o doppio pulsante. Oltre tale peso l'utensile viene fornito con spine.  
*Tools with a weight less than 12,5 kg are supplied with a single or double push buttons. Beyond such weight the tool is supplied with pins.*

altezza height mm	angolo degree	raggio radius	acciaio steel	max kN/mt
237,0	85°	0,8	42CM4 T HRC 52-58	800
lunghezze - lengths		mm 515 - fraz L 550 (2)		

**serie UST**®

**Non troverete in nessun altro luogo una pellicola più tenace e duratura !!!**  
**Nowhere else you can find a more strong and lasting film !!!**



**GIMEC URET**  
**PELLICOLA ANTIGRAFFIO - DIE COVER FILM**

**trovala a pagina 120**  
**find it on page 120**

**STANDARD TOOLS**

**UST 60° R4,0/S**

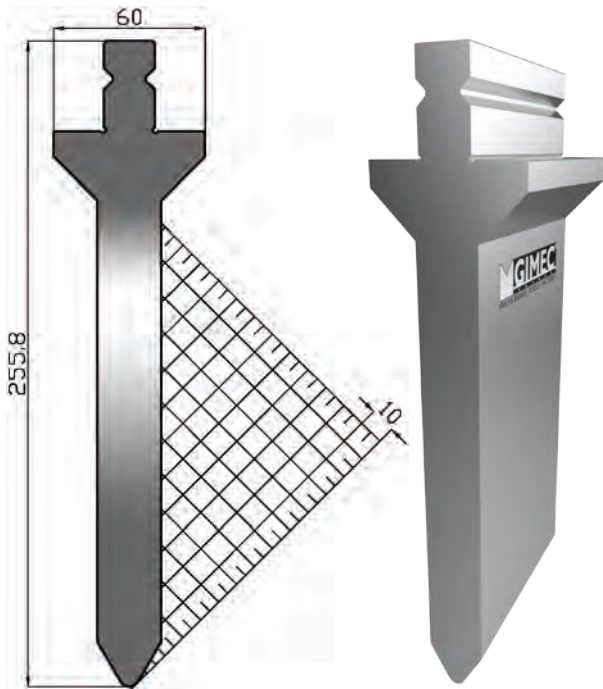

altezza height mm	angolo degree	raggio radius	acciaio steel	max kN/mt
255,8	60°	4,0	42CM4 T HRC 52-58	1300
lunghezze - lengths			mm 500 - fraz L 550 (1)	

**UST 28° R1,0/S**

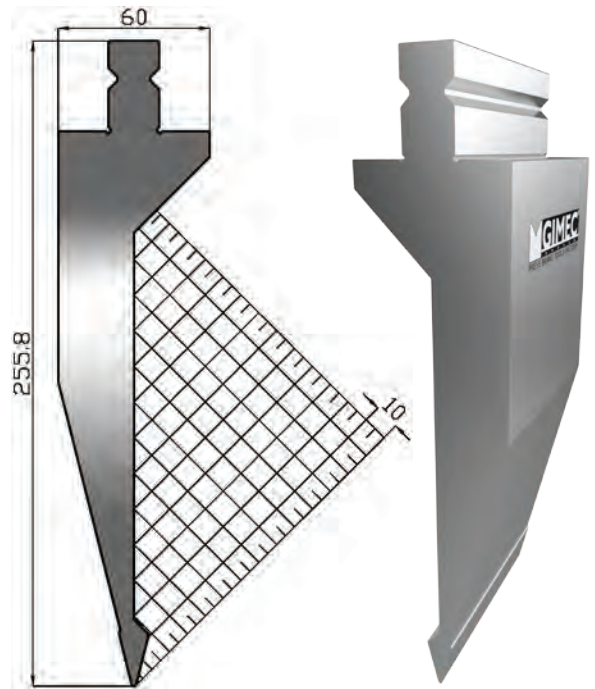

altezza height mm	angolo degree	raggio radius	acciaio steel	max kN/mt
255,8	28°	1,0	42CM4 T HRC 52-58	600
lunghezze - lengths			mm 500 - fraz L 550 (1)	

**UST 86° R1,0/A**

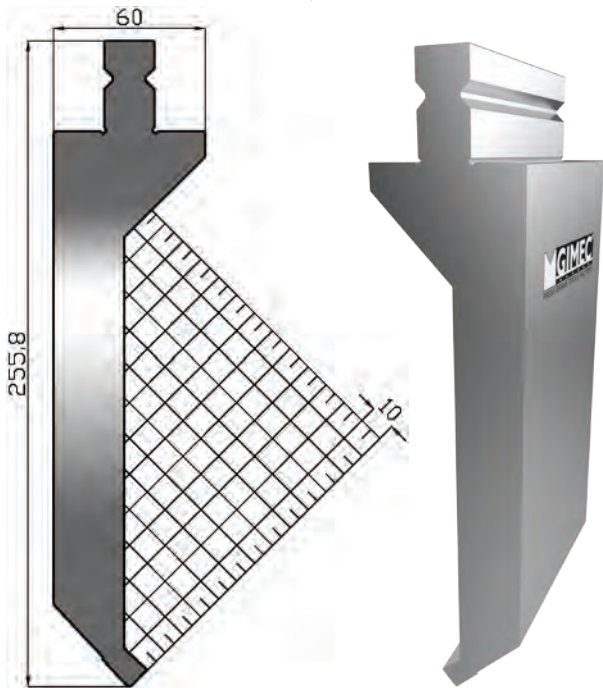

altezza height mm	angolo degree	raggio radius	acciaio steel	max kN/mt
255,8	86°	1,0	42CM4 T HRC 52-58	800
lunghezze - lengths			mm 500 - fraz L 550 (1)	

**UST 86° R1,0/S**

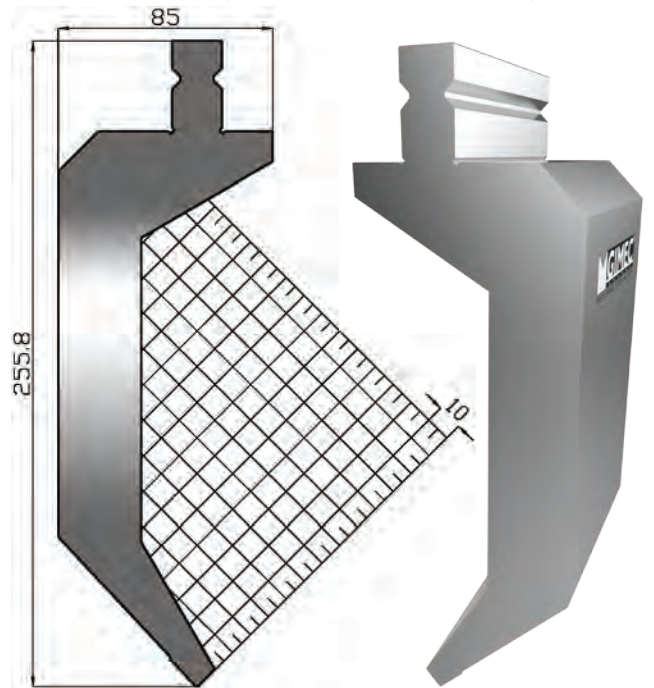

altezza height mm	angolo degree	raggio radius	acciaio steel	max kN/mt
255,8	86°	1,0	42CM4 T HRC 52-58	800
lunghezze - lengths			mm 500 - fraz L 550 (1)	

serie UST®

STANDARD TOOLS



**UST 28° R1,0/SP**

**UST 176 SP / 28° R1,0**

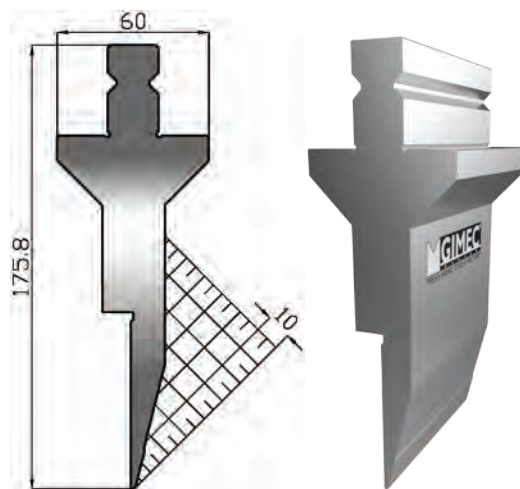
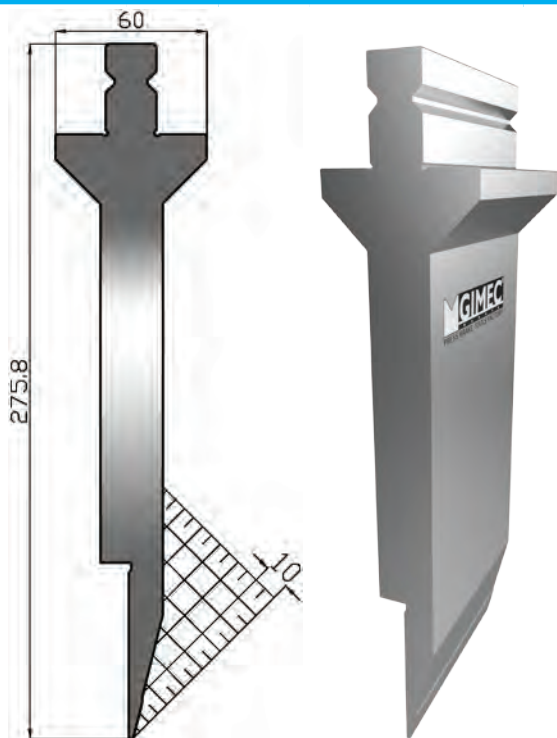

altezza height mm	angolo degree	raggio radius	acciaio steel	max kN/mt
275,8	28°	1,0	42CM4 T HRC 52÷58	400
lunghezze - lengths		mm 500 - fraz L 550 (1)		

altezza height mm	angolo degree	raggio radius	acciaio steel	max kN/mt
175,8	28°	1,0	42CM4 T HRC 52÷58	400
lunghezze - lengths		mm 500 - fraz L 550 (1A)		

**LUNGHEZZE • LENGTHS mm 500 - 515 - fraz 10 pz/pcs L 550 (1) (1A) (2) (P)**

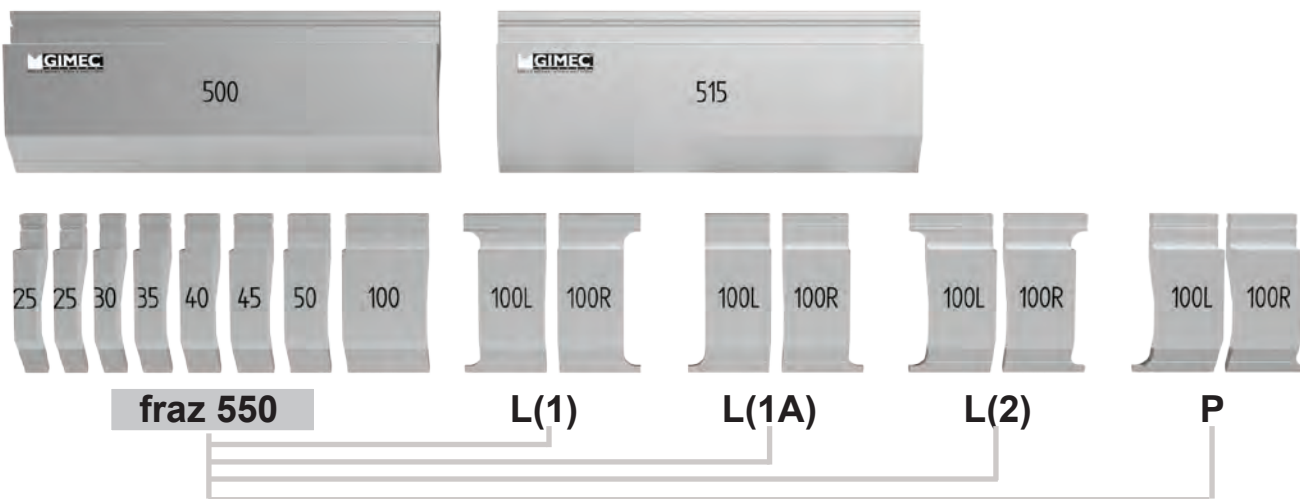

**LUNGHEZZE • LENGTHS mm 515 - fraz 8 pz/pcs L 550 W**

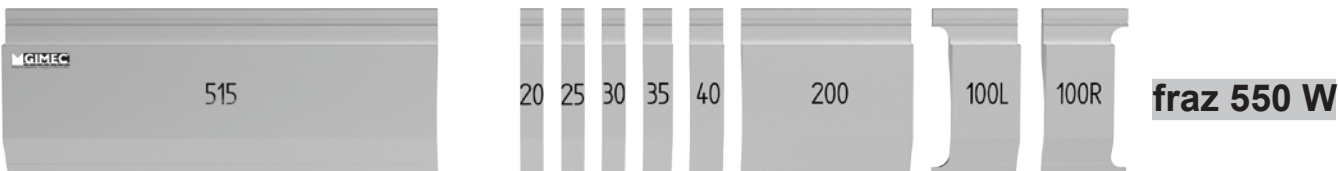

**serie UST®**

**STANDARD TOOLS**

**UST 138 L 8**

**UST 138 M 8**

**UST 138 L 10**

**UST 138 M 10**

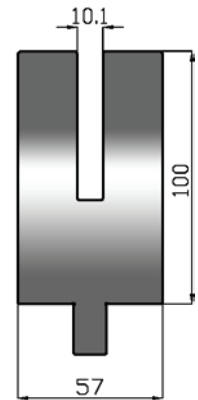
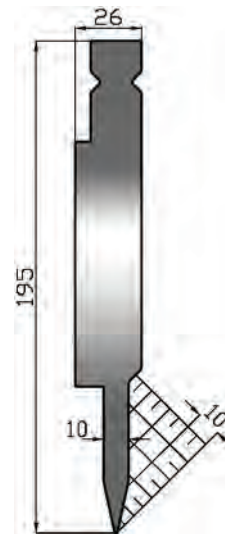
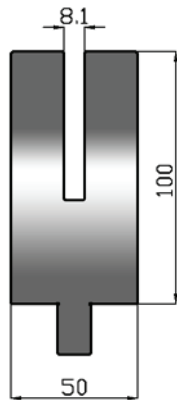

altezza height	angolo degree	raggio radius	max kN/mt	altezza height	V mm	raggio radius	max kN/mt
mm 195	24°	0,6	800	mm100	8	1,0	500
acciaio - steel C45 T HRC 52-58							
lunghezze - lengths mm 500 - 550 fraz							

altezza height	angolo degree	raggio radius	max kN/mt	altezza height	V mm	raggio radius	max kN/mt
mm 195	24°	0,6	800	mm100	10	1,0	500
acciaio - steel C45 T HRC 52-58							
lunghezze - lengths mm 500 - 550 fraz							

**UST 138 L 12**

**UST 138 M 12**

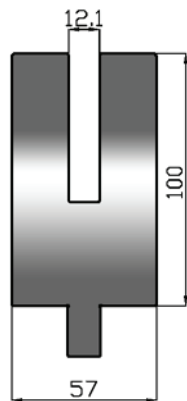

altezza height	angolo degree	raggio radius	max kN/mt	altezza height	V mm	raggio radius	max kN/mt
mm 195	24°	0,6	800	mm100	12	1,0	500
acciaio - steel C45 T HRC 52-58							
lunghezze - lengths mm 500 - 550 fraz							



Si consiglia di utilizzare questi utensili su presse piegatrici sincronizzate in quanto occorre variare rapidamente la corsa della pressa tra la fase di piegatura e quella di schiacciatura. Non è possibile aumentare il raggio della matrice in quanto si potrebbero verificare deformazioni anomale della piega schiacciata.

*We suggest to use these tools on synchronized press brakes as it is necessary to change quickly press stroke between bending and crushing position. It is not possible to increase lower tool radius because it would have some deformations on bend crushed.*

**UST 130**

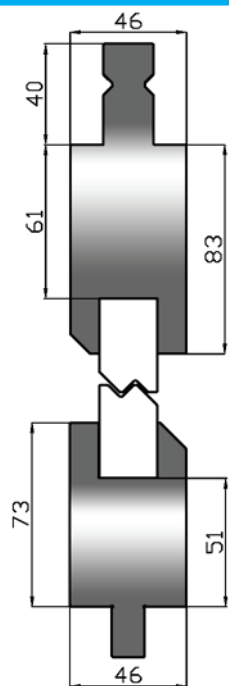

altezza height mm	acciaio steel	max kN/mt
73 + 83	C45	1000
lunghezze - lengths	mm 835 - 415	

**US 131 Z 1 ÷ 15 mm**

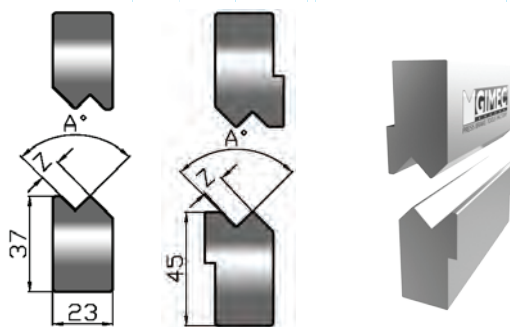

codice articolo item code	Z mm	A°	MAX sp./th.	codice articolo item code	Z mm	A°	MAX sp./th.
US 131 / 1,0	1,0	160°	0,5 mm	US 131 / 6,5	6,5	90°	1,5 mm
US 131 / 1,5	1,5	160°	0,6 mm	US 131 / 7,0	7,0	90°	2,0 mm
US 131 / 2,0	2,0	150°	0,8 mm	US 131 / 7,5	7,5	90°	2,0 mm
US 131 / 2,5	2,5	140°	1,0 mm	US 131 / 8	8	90°	2,5 mm
US 131 / 3,0	3,0	90°	1,0 mm	US 131 / 9	9	90°	2,5 mm
US 131 / 3,5	3,5	90°	1,2 mm	US 131 / 10	10	90°	3,0 mm
US 131 / 4,0	4,0	90°	1,2 mm	US 131 / 11	11	90°	3,0 mm
US 131 / 4,5	4,5	90°	1,5 mm	US 131 / 12	12	90°	3,0 mm
US 131 / 5,0	5,0	90°	1,5 mm	US 131 / 13	13	90°	3,0 mm
US 131 / 5,5	5,5	90°	1,5 mm	US 131 / 14	14	90°	3,0 mm
US 131 / 6,0	6,0	90°	1,5 mm	US 131 / 15	15	90°	3,0 mm

acciaio - steel	C45 T HRC 52÷58
lunghezze - lengths	mm 835 - 415

**US 305 R 8 ÷ 50 mm**

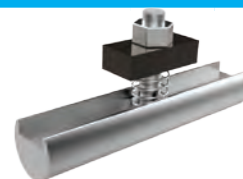
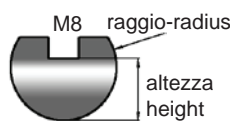

4 fori-holes mm 104-209-...-104 = mm 835  
2 fori-holes mm 103-209-...-103 = mm 415

codice articolo item code	raggio radius	altezza height	codice articolo item code	raggio radius	altezza height
US 305/R 8	8	10 mm	US 305/R 25	25	29 mm
US 305/R 9	9	10 mm	US 305/R 27,5	27,5	34 mm
US 305/R 10	10	12 mm	US 305/R 30	30	34 mm
US 305/R 12,5	12,5	17 mm	US 305/R 35	35	45 mm
US 305/R 15	15	20 mm	US 305/R 40	40	44 mm
US 305/R 17,5	17,5	22 mm	US 305/R 45	45	50 mm
US 305/R 20	20	24 mm	US 305/R 50	50	54 mm
US 305/R 22,5	22,5	25 mm			

acciaio - steel	C45 - 39NCM3 nitratato (N)
lunghezze - lengths	mm 835 - 415

**US 310**

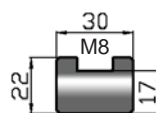

4 fori-holes mm 104-209-...-104 = mm 835  
2 fori-holes mm 103-209-...-103 = mm 415

codice articolo item code	acciaio steel
US 310	C45
US 310 T	C45 T HRC 52÷58
lunghezze - lengths	mm 835 - 415

**UST 140**

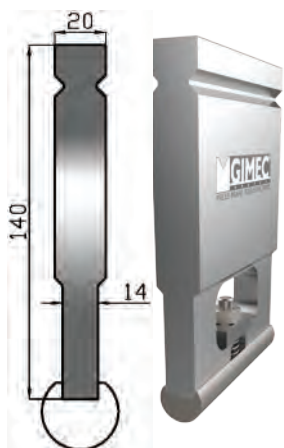

**UST 256**



altezza height mm 140	altezza height mm 256		
raggio-radius MIN-MAX	8÷50 mm	acciaio steel	C45
lunghezze lengths	mm 830-412	max kN/mt	800

serie UST®

STANDARD TOOLS

<b>86°</b>		codice articolo item code	V <sub>mm</sub>	R <sub>mm</sub>	H-H1 <sub>mm</sub>	S-S1 <sub>mm</sub>	max kN/mt	
		UST100N-S/86°V04	4	0,6	100-14	20 - 8	250	
		UST100 N / 86° V06	6	0,6	100	20	1200	
		UST100 N / 86° V08	8	0,8	100	20	1150	
		UST100 N / 86° V10	10	1,0	100	20	1100	
		UST100 N / 86° V12	12	1,0	100	25	1200	
		UST100 N / 86° V16	16	1,6	100	30	1200	
		UST100 N / 86° V20	20	2,0	100	30	1150	
		UST100 N / 86° V24	24	2,5	100	35	1200	
		UST100 N / 86° V30	30	3,0	100	45	1200	
		UST100 N / 86° V40	40	3,0	100	55	1200	
		UST100 N / 86° V50	50	3,0	100	75	1500	
		UST150 N / 86° V06	6	1,6	150-10	30-20	1200	
		UST150 N / 86° V08	8	2,0	150-10	30-20	1150	
		UST150 N / 86° V10	10	2,5	150-10	30-20	1100	
		UST150 N / 86° V12	12	3,0	150	25	1200	
		UST150 N / 86° V16	16	3,0	150	30	1200	
		UST150 N / 86° V20	20	3,0	150	30	1150	
	acciaio - steel		42CM4 T HRC 52:58		lunghezze - lengths		mm 500 - fraz C - M	

<b>86°</b>		codice articolo item code	V <sub>mm</sub>	R <sub>mm</sub>	H-H1 <sub>mm</sub>	S-S1 <sub>mm</sub>	max kN/mt
		UST100N-S/86°V08	8	2,5	100-10	25-16	400
		UST100N-S/86°V12	12	3,0	100-10	25-20	1200
acciaio - steel		42CM4 T HRC 52:58		lunghezze - lengths		mm 515 - fraz M	

<b>80° 60°</b>		codice articolo item code	V <sub>mm</sub>	R <sub>mm</sub>	H	S	max kN/mt	
		UST150 N / 80° V24	24	2,0	150	35	1000	
		UST150 N / 80° V30	30	5,0	150	45	900	
		UST150 N / 80° V40	40	5,0	150	55	1200	
		UST150 N / 80° V50	50	5,0	150	65	1500	
		UST100 N / 80° V60	60	5,0	100	75	1500	
		UST100 N / 80° V70	70	5,0	100	85	1500	
		UST100 N / 80° V80	80	5,0	100	100	1500	
		UST120 N / 80° V90	90	8,0	120	110	1500	
		UST120 N / 80°V100	100	8,0	120	120	1500	
		UST120 N / 60°V120	120	8,0	120	145	1600	
	acciaio - steel		42CM4 T HRC 52:58		lunghezze - lengths		mm 500 - fraz C - M	

30°		codice articolo item code	V <sub>mm</sub>	R <sub>mm</sub>	H-H1 <sub>mm</sub>	S-S1 <sub>mm</sub>	max kN/mt	
		UST100 N / 30° V06	6	0,6	100	20	400	
		UST100 N / 30° V08	8	1,0	100	20	400	
		UST100 N / 30° V10	10	1,0	100	20	400	
		UST100 N / 30° V12	12	1,0	100	25	400	
		UST100 N / 30° V16	16	1,6	100	30	500	
		UST100 N / 30° V20	20	2,0	100	35	600	
		UST100 N / 30° V24	24	2,5	100	40	650	
		UST100 N / 30° V30	30	3,0	100	55	900	
		UST100 N / 30° V40	40	5,0	100	60	900	
		UST150 N / 30° V06	6	0,6	150-10	30-20	400	
		UST150 N / 30° V08	8	1,0	150-10	30-20	400	
		UST150 N / 30° V10	10	1,0	150-10	30-20	400	
		UST150 N / 30° V12	12	1,0	150	25	400	
		UST150 N / 30° V16	16	1,6	150	30	500	
		UST150 N / 30° V20	20	2,0	150	35	600	
		UST150 N / 30° V24	24	2,5	150	40	650	
		UST150 N / 30° V30	30	3,0	150	55	900	
		UST150 N / 30° V40	40	5,0	150	60	900	
	acciaio - steel	42CM4 T HRC 52÷58	lunghezze - lengths		mm 500 - fraz C - M			

30°		codice articolo item code	V <sub>mm</sub>	R <sub>mm</sub>	H-H1 <sub>mm</sub>	S-S1 <sub>mm</sub>	max kN/mt
		UST100N-S/30°V06	6	2,0	100-10	25-16	400
		UST100N-S/30°V08	8	2,5	100-10	25-16	400
		UST100N-S/30°V10	10	2,5	100-10	25-20	400
		UST100N-S/30°V12	12	3,0	100-10	25-20	400
acciaio - steel	42CM4 T HRC 52÷58	lunghezze - lengths		mm 515 - fraz M			

**LUNGHEZZE • LENGTHS mm 500 - 515 - fraz C250 - M550**

L mm	25	30	35	40	45	50	100	200				tot.pz/pcs
<b>fraz C</b>	250	2	1	1	1	1	1					<b>7</b>
<b>fraz M</b>	550	2	1	1	1	1	1	1				<b>9</b>

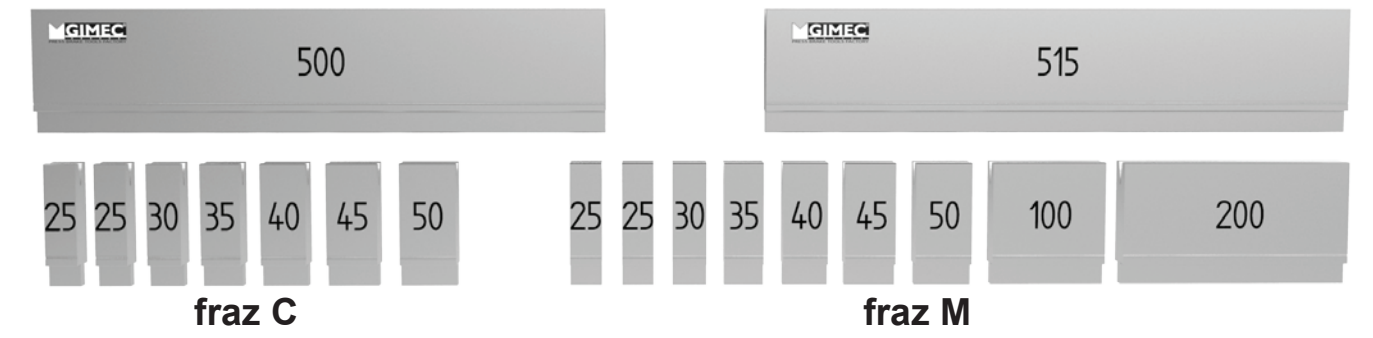

STANDARD TOOLS serie 13 UST®

**USB 155/28° R3,0 / S**

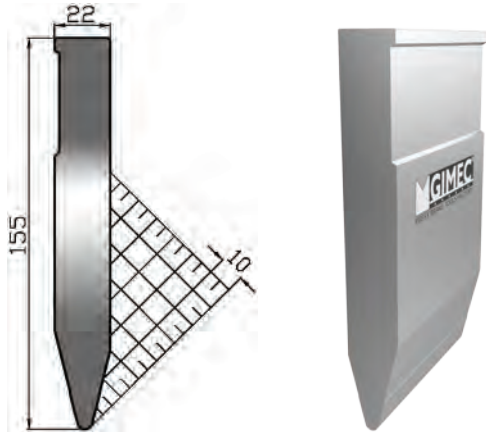

altezza height mm	angolo degree	raggio radius	acciaio steel	max kN/mt
155,0	28°	3,0	42CM4 T HRC 52-58	1000
lunghezze - lengths		mm 500 - 1000 - 1100 fraz (1)		

**USB 155/28° R3,0 / R**

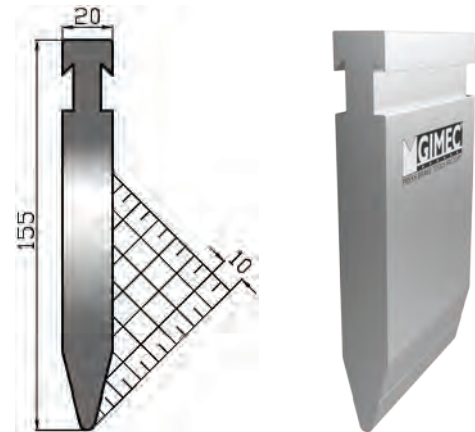

altezza height mm	angolo degree	raggio radius	acciaio steel	max kN/mt
155,0	28°	3,0	42CM4 T HRC 52-58	1000
lunghezze - lengths		mm 500 - 1000 - 1100 fraz (1)		

**USB 155/30° R1,0 / S**

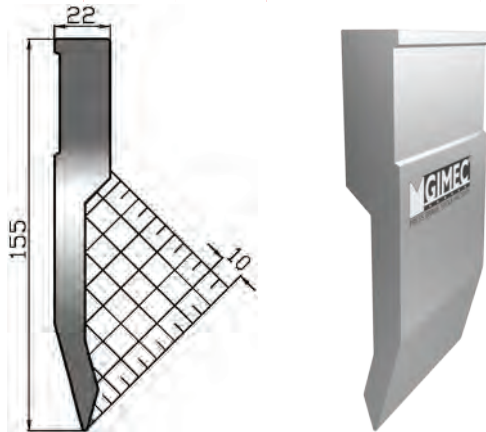

altezza height mm	angolo degree	raggio radius	acciaio steel	max kN/mt
155,0	30°	1,0	42CM4 T HRC 52-58	800
lunghezze - lengths		mm 500 - 1000 - 1100 fraz (1)		

**USB 155/30° R1,0 / R**

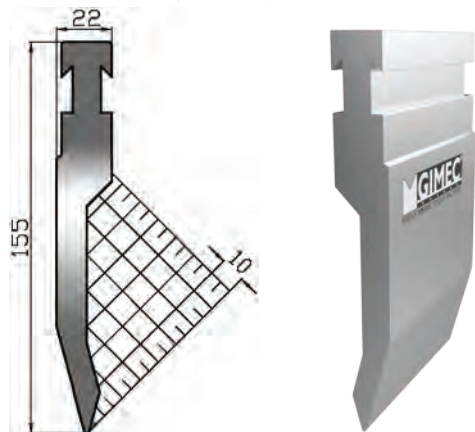

altezza height mm	angolo degree	raggio radius	acciaio steel	max kN/mt
155,0	30°	1,0	42CM4 T HRC 52-58	800
lunghezze - lengths		mm 500 - 1000 - 1100 fraz (1)		

**USB 155/85° D R1,0 / S**

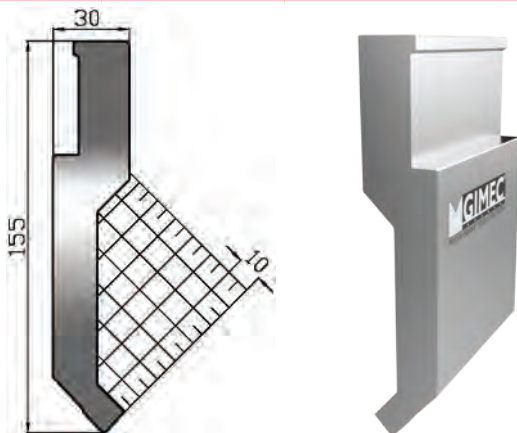

altezza height mm	angolo degree	raggio radius	acciaio steel	max kN/mt
155,0	85°	1,0	42CM4 T HRC 52-58	1000
lunghezze - lengths		mm 500 - 1000 - 1100 fraz (1)		

**USB 155/85° D R1,0 / R**

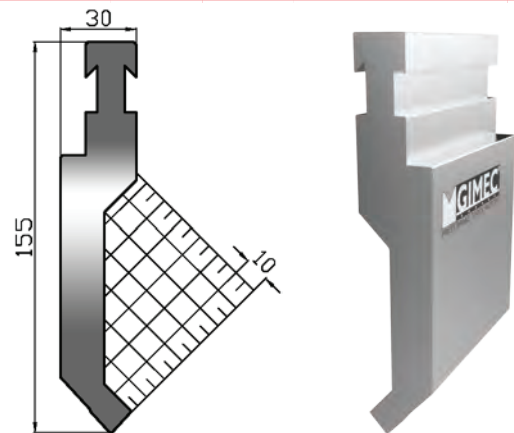

altezza height mm	angolo degree	raggio radius	acciaio steel	max kN/mt
155,0	85°	1,0	42CM4 T HRC 52-58	1000
lunghezze - lengths		mm 500 - 1000 - 1100 fraz (1)		

serie USB®

STANDARD TOOLS

**USB 155/85° C R0,8 / S**

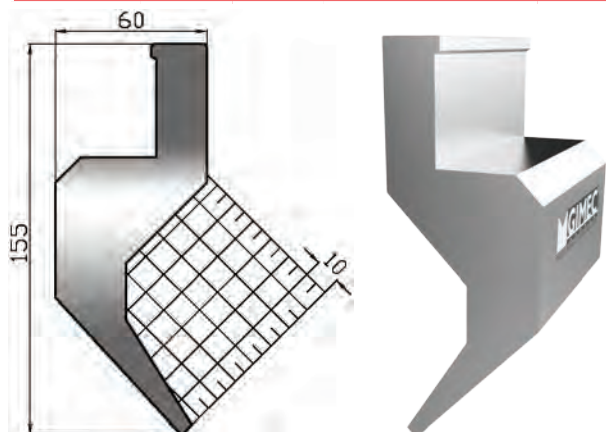

altezza height mm	angolo degree	raggio radius	acciaio steel	max kN/mt
155,0	85°	0,8	42CM4 T HRC 52-58	500
lunghezze - lengths		mm 500 - 1000 - 1100 fraz (1)		

**USB 155/85° C R0,8 / R**

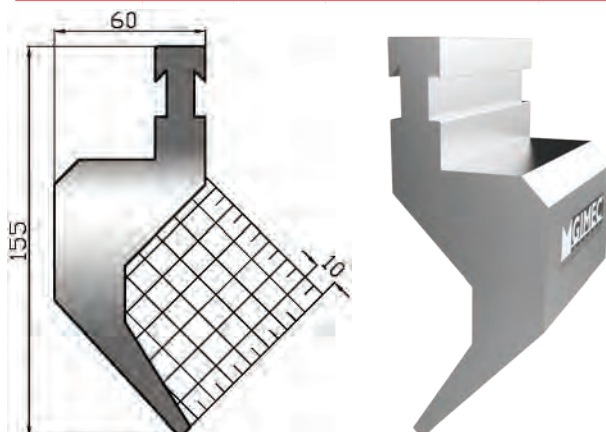

altezza height mm	angolo degree	raggio radius	acciaio steel	max kN/mt
155,0	85°	0,8	42CM4 T HRC 52-58	500
lunghezze - lengths		mm 500 - 1000 - 1100 fraz (1)		

**USB 155/85° C R1,5 / S**

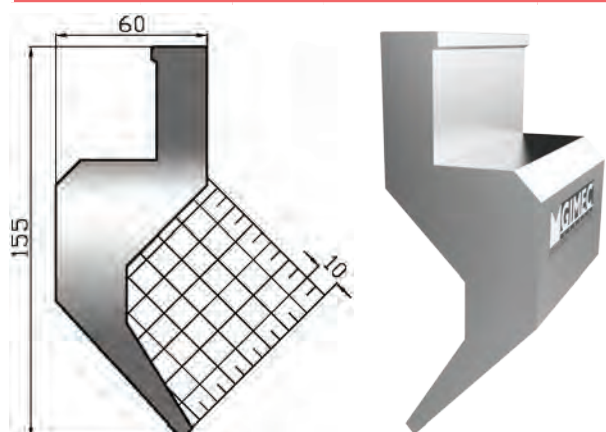

altezza height mm	angolo degree	raggio radius	acciaio steel	max kN/mt
155,0	85°	1,5	42CM4 T HRC 52-58	500
lunghezze - lengths		mm 500 - 1000 - 1100 fraz (1)		

**USB 155/85° C R1,5 / R**

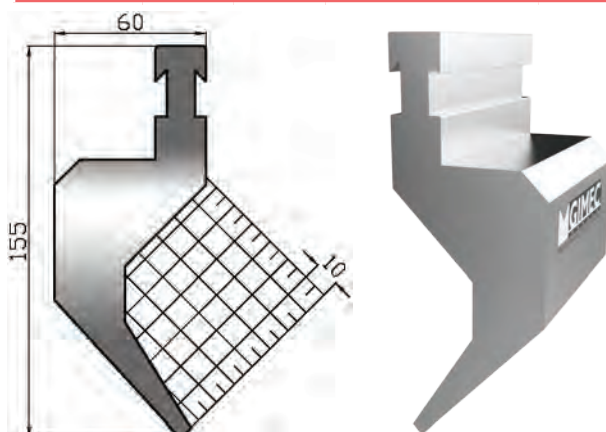

altezza height mm	angolo degree	raggio radius	acciaio steel	max kN/mt
155,0	85°	1,5	42CM4 T HRC 52-58	500
lunghezze - lengths		mm 500 - 1000 - 1100 fraz (1)		

**USB 155 LUNGHEZZE • LENGTHS**

mm 1000 - 500 - fraz 1100 (1) mm10+15+20+30+40+50+60+75+100+100L+100R+200+300

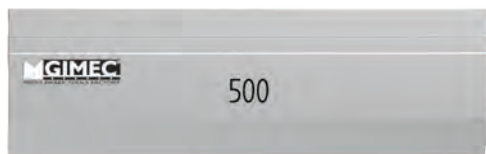

serie USB®

STANDARD TOOLS

**USB 175/30° R1,0 / RFA**

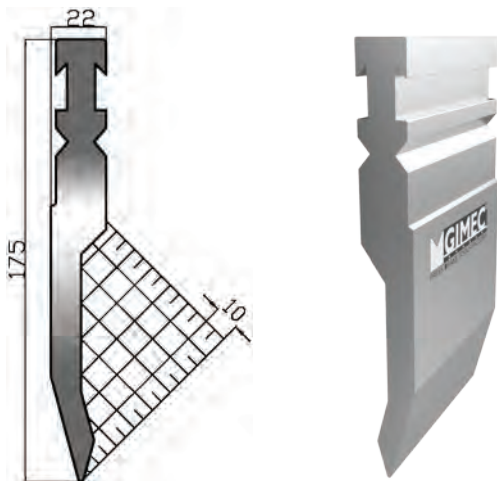

altezza height mm	angolo degree	raggio radius	acciaio steel	max kN/mt
175,0	30°	1,0	42CM4 T HRC 52-58	800
lunghezze - lengths			mm 500 - 1000 - 1100 fraz (1)	

**USB 175/88° D R1,0 / RFA**

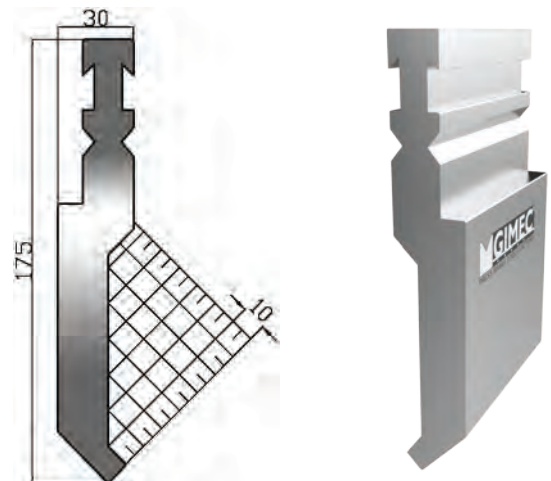

altezza height mm	angolo degree	raggio radius	acciaio steel	max kN/mt
175,0	88°	1,0	42CM4 T HRC 52-58	1000
lunghezze - lengths			mm 500 - 1000 - 1100 fraz (1)	

**USB 175/88° C R1,5 / RFA**

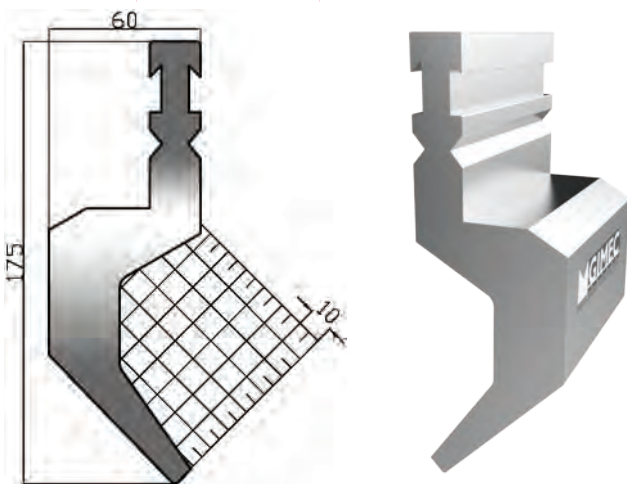

altezza height mm	angolo degree	raggio radius	acciaio steel	max kN/mt
175,0	88°	1,5	42CM4 T HRC 52-58	500
lunghezze - lengths			mm 500 - 1000 - 1100 fraz (1)	



**USB 175 LUNGHEZZE • LENGTHS**

mm 1000 - 500 - fraz 1100 (1) mm10+15+20+30+40+50+60+75+100+100L+100R+200+300



serie **USB**®

STANDARD TOOLS



**USB 250/26° R1,0 / RFA**

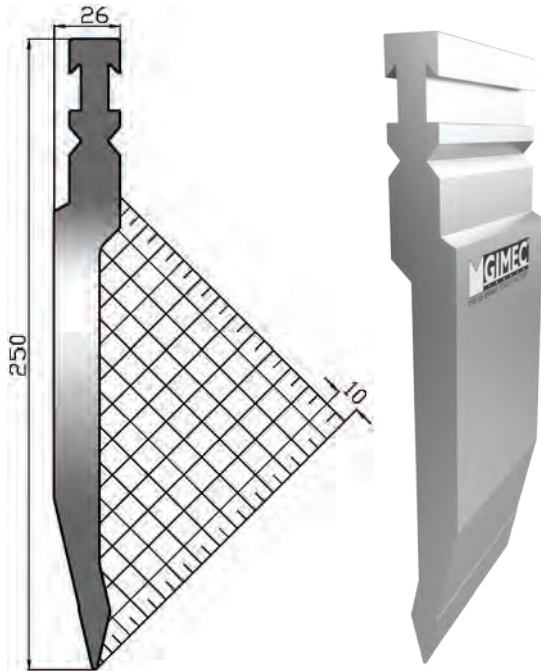

**USB 250/85° R1,5 / RFA**

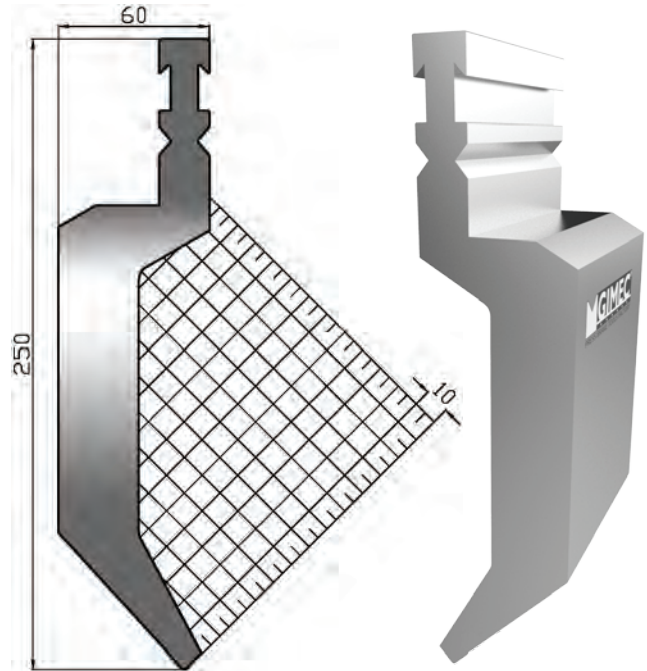

altezza height mm	angolo degree	raggio radius	acciaio steel	max kN/mt
250,0	26°	1,0	42CM4 T HRC 52-58	900
lunghezze - lengths		mm 508 - 1100 fraz (2)		

altezza height mm	angolo degree	raggio radius	acciaio steel	max kN/mt
250,0	85°	1,5	42CM4 T HRC 52-58	1000
lunghezze - lengths		mm 508 - 1100 fraz (2)		

serie USB®

**USB 250 LUNGHEZZE • LENGTHS**

mm 508 - fraz 1100 (2) mm 10+15+20+30+50+200L+100R+300+375



STANDARD TOOLS

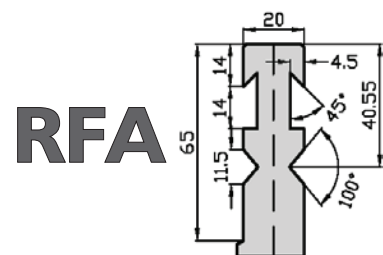
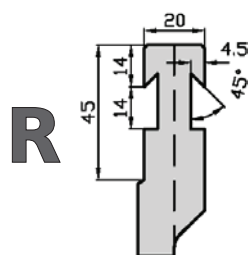
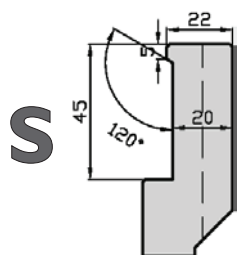

**USB 138 L 8**

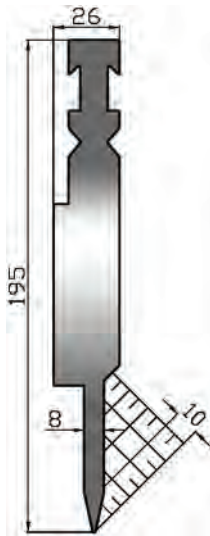

**USB 138 M 8**

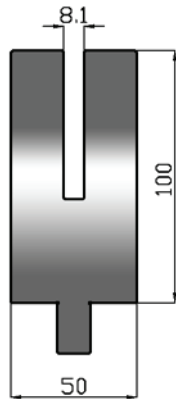

**USB 138 L 10**

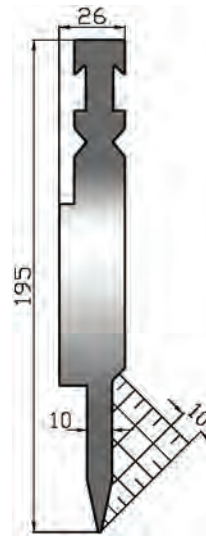

**USB 138 M 10**

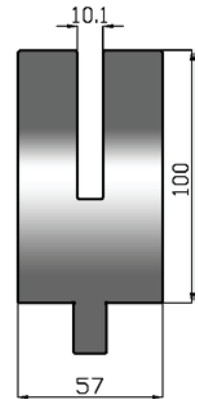

altezza height	angolo degree	raggio radius	max kN/mt	altezza height	V mm	raggio radius	max kN/mt
mm 195	24°	0,6	800	mm100	8	1,0	500
acciaio - steel C45 T HRC 52-58							
lunghezze - lengths mm 500 - 550 fraz							

altezza height	angolo degree	raggio radius	max kN/mt	altezza height	V mm	raggio radius	max kN/mt
mm 195	24°	0,6	800	mm100	10	1,0	500
acciaio - steel C45 T HRC 52-58							
lunghezze - lengths mm 500 - 550 fraz							

**USB 138 L 12**



**USB 138 M 12**

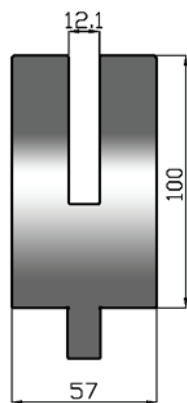

altezza height	angolo degree	raggio radius	max kN/mt	altezza height	V mm	raggio radius	max kN/mt
mm 195	24°	0,6	800	mm100	12	1,0	500
acciaio - steel C45 T HRC 52-58							
lunghezze - lengths mm 500 - 550 fraz							



Si consiglia di utilizzare questi utensili su presse piegatrici sincronizzate in quanto occorre variare rapidamente la corsa della pressa tra la fase di piegatura e quella di schiacciatura. Non è possibile aumentare il raggio della matrice in quanto si potrebbero verificare deformazioni anomale della piega schiacciata.

*We suggest to use these tools on synchronized press brakes as it is necessary to change quickly press stroke between bending and crushing position. It is not possible to increase lower tool radius because it would have some deformations on bend crushed.*

**USB 130**

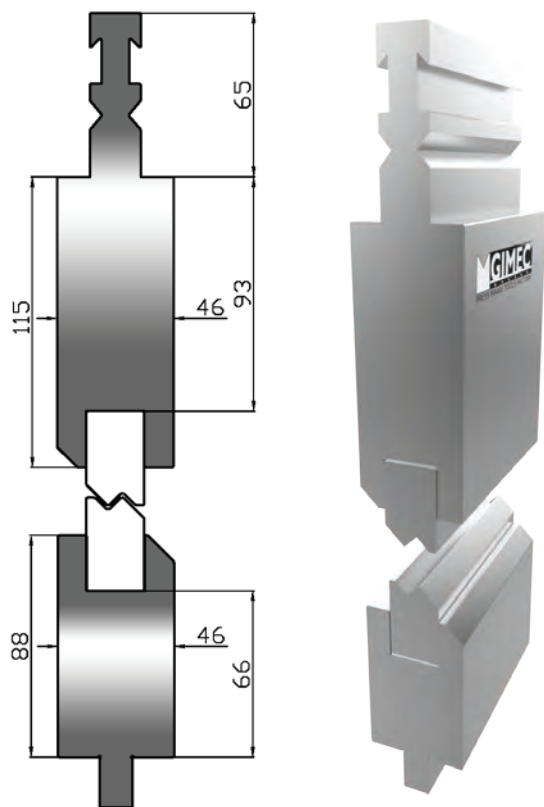

altezza height mm	acciaio steel	max kN/mt
115 + 88	C45	1000
lunghezze - lengths	mm 835 - 415	

**US 131 Z 1 ÷ 15 mm**

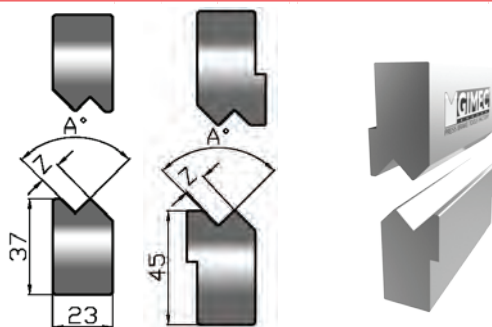

codice articolo item code	Z mm	A°	MAX sp./th.	codice articolo item code	Z mm	A°	MAX sp./th.
US 131 / 1,0	1,0	160°	0,5 mm	US 131 / 6,5	6,5	90°	1,5 mm
US 131 / 1,5	1,5	160°	0,6 mm	US 131 / 7,0	7,0	90°	2,0 mm
US 131 / 2,0	2,0	150°	0,8 mm	US 131 / 7,5	7,5	90°	2,0 mm
US 131 / 2,5	2,5	140°	1,0 mm	US 131 / 8	8	90°	2,5 mm
US 131 / 3,0	3,0	90°	1,0 mm	US 131 / 9	9	90°	2,5 mm
US 131 / 3,5	3,5	90°	1,2 mm	US 131 / 10	10	90°	3,0 mm
US 131 / 4,0	4,0	90°	1,2 mm	US 131 / 11	11	90°	3,0 mm
US 131 / 4,5	4,5	90°	1,5 mm	US 131 / 12	12	90°	3,0 mm
US 131 / 5,0	5,0	90°	1,5 mm	US 131 / 13	13	90°	3,0 mm
US 131 / 5,5	5,5	90°	1,5 mm	US 131 / 14	14	90°	3,0 mm
US 131 / 6,0	6,0	90°	1,5 mm	US 131 / 15	15	90°	3,0 mm
acciaio - steel	C45 T HRC 52÷58						
lunghezze - lengths	mm 835 - 415						

**US 305 R 8 ÷ 50 mm**

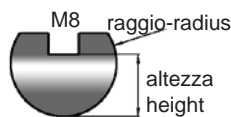

4 fori-holes mm 104-209-...-104 = mm 835  
2 fori-holes mm 103-209-...-103 = mm 415

codice articolo item code	raggio radius	altezza height	codice articolo item code	raggio radius	altezza height
US 305/R 8	8	10 mm	US 305/R 25	25	29 mm
US 305/R 9	9	10 mm	US 305/R 27,5	27,5	34 mm
US 305/R 10	10	12 mm	US 305/R 30	30	34 mm
US 305/R 12,5	12,5	17 mm	US 305/R 35	35	45 mm
US 305/R 15	15	20 mm	US 305/R 40	40	44 mm
US 305/R 17,5	17,5	22 mm	US 305/R 45	45	50 mm
US 305/R 20	20	24 mm	US 305/R 50	50	54 mm
US 305/R 22,5	22,5	25 mm			
acciaio - steel	C45 - 39NCM3 nitratato (N)				
lunghezze - lengths	mm 835 - 415				

**USB 140 /S**

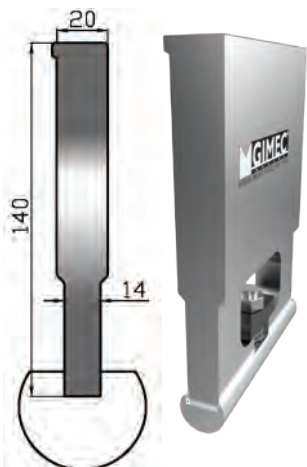

**USB 140 /RFA**

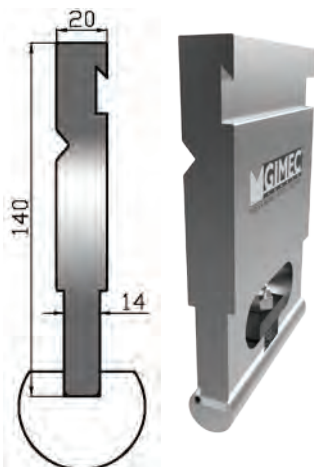

altezza height mm	140
raggio-radius MIN - MAX	8 ÷ 50 mm
acciaio steel	C45
lunghezze lengths	mm 830 - 412
max kN/mt	800

altezza height mm	140
raggio-radius MIN - MAX	8 ÷ 50 mm
acciaio steel	C45
lunghezze lengths	mm 830 - 412
max kN/mt	800

**US 310**

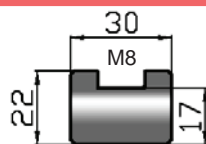





4 fori-holes mm 104-209-...-104 = mm 835  
2 fori-holes mm 103-209-...-103 = mm 415

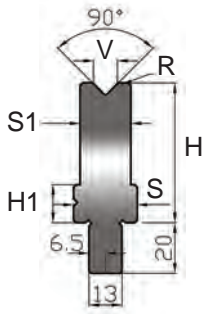

codice articolo item code	acciaio steel
US 310	C45
US 310 T	C45 T HRC 52÷58
lunghezze - lengths	mm 835 - 415

serie USB®

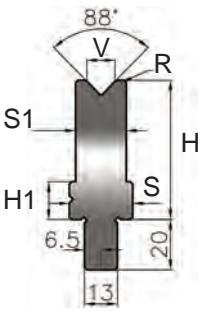
STANDARD TOOLS

90°		codice articolo item code	V mm	R mm	H-H1 mm	S-S1 mm	max kN/mt
		USB55 / 90° V06	6	0,4	55-15	25-15	1150
		USB55 / 90° V08	8	0,5	55-15	25-15	1100
		USB55 / 90° V10	10	1,0	55-15	25-20	1100
		USB55 / 90° V12	12	1,5	55-15	25-20	1200
		USB55 / 90° V16	16	2,0	55	30	1200
acciaio - steel		42CM4 T HRC 52÷58	lunghezze - lengths		mm 500 - 1000 - fraz 1100		

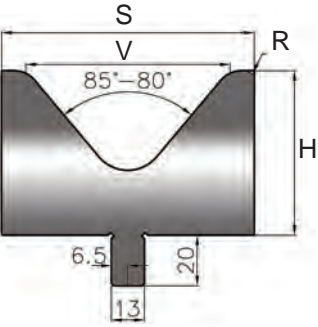
88°		codice articolo item code	V mm	R mm	H-H1 mm	S-S1 mm	max kN/mt
		USB55 / 88° V10	10	1,0	55-15	25-20	1100
		USB55 / 88° V12	12	1,5	55-15	25-20	1200
		USB55 / 88° V16	16	2,0	55	30	1200
		USB55 / 88° V20	20	2,0	55	30	1100
		USB55 / 88° V24	24	3,0	55	40	1200
acciaio - steel		42CM4 T HRC 52÷58	lunghezze - lengths		mm 500 - 1000 - fraz 1100		

85° 80°		codice articolo item code	V mm	R mm	H mm	S mm	max kN/mt
		USB55 / 85° V32	32	4,0	55	50	1200
		USB55 / 85° V40	40	4,0	55	55	1200
		USB65 / 80° V80	80	10,0	65	100	1700
		USB85 / 80° V100	100	12,0	85	125	2300
acciaio - steel		42CM4 T HRC 52÷58	lunghezze - lengths		mm 500 - 1000 - fraz 1100		

60°		codice articolo item code	V mm	R mm	H mm	S mm	max kN/mt
		USB55 / 60° V40	40	5,0	55	55	1300
		USB55 / 60° V50	50	5,0	55	70	1200
		USB65 / 60° V60	60	7,0	65	80	1100
acciaio - steel		42CM4 T HRC 52-58	lunghezze - lengths		mm 500 - 1000 - fraz 1100		

30°		codice articolo item code	V mm	R mm	H-H1 mm	S-S1 mm	max kN/mt	
		USB55 / 30° V06	6	0,6	55-15	25-15	350	
		USB55 / 30° V08	8	0,8	55-15	25-15	200	
		USB70 / 30° V08	8	0,7	70-15	25-20	200	
		USB55 / 30° V10	10	1,0	55-15	25-20	350	
		USB70 / 30° V10	10	1,0	70-15	25-20	350	
		USB55 / 30° V12	12	1,5	55-15	25-20	300	
		USB70 / 30° V12	12	1,5	70	25-25	300	
		USB55 / 30° V12 P	12	2,0	55	35	500	
		USB55 / 30° V14 P	14	3,0	55	42	600	
		USB55 / 30° V16	16	2,0	55	30	450	
		USB70 / 30° V16	16	2,0	70	30	450	
		USB55 / 30° V20	20	2,5	55	35	500	
		USB55 / 30° V24	24	3,0	55	40	550	
		USB60 / 30° V32	32	4,0	60	60	650	
acciaio - steel		42CM4 T HRC 52-58	lunghezze - lengths		mm 500 - 1000 - fraz 1100			

**LUNGHEZZE • LENGTHS**  
 mm 500 - 1000 - fraz 1100 mm 10+15+20+30+40+50+60+75+100+100+200+400

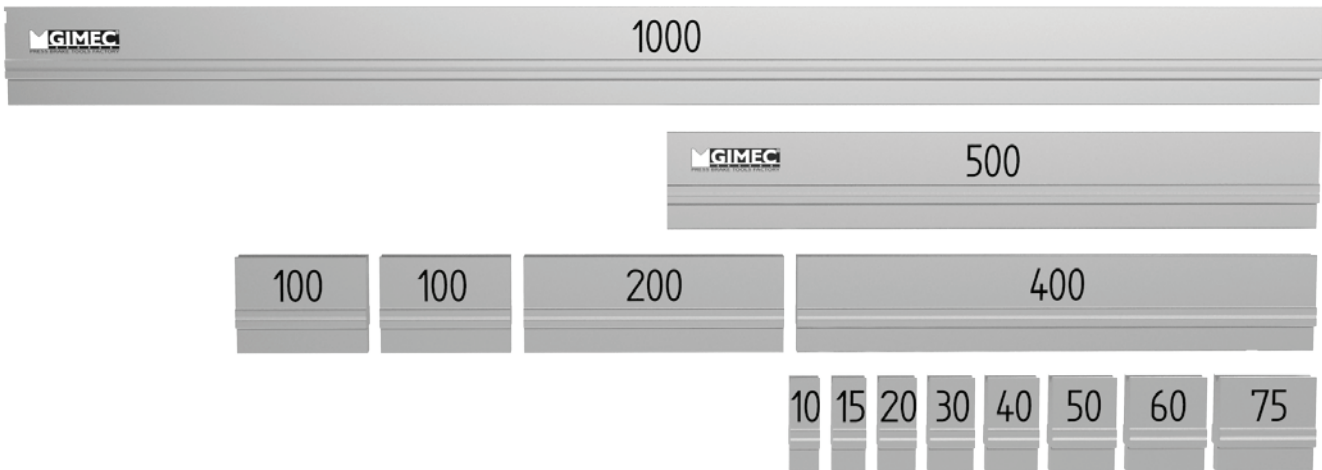

**STANDARD TOOLS**  
**serie 13 USB®**

**USL 196/26° R1 J10W**

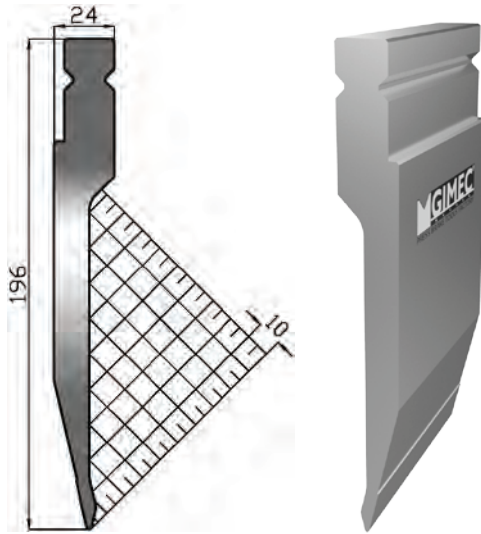

**USL 196/26° R2 J10W**

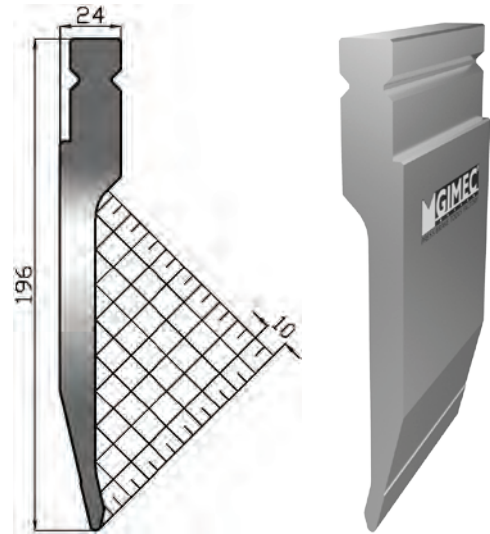

altezza height mm	angolo degree	raggio radius	acciaio steel	max kN/mt
196,0	26°	1,0	42CM4 T HRC 52-58	400
lunghezze - lengths			mm 510 - 250 - 550 fraz	

altezza height mm	angolo degree	raggio radius	acciaio steel	max kN/mt
196,0	26°	2,0	42CM4 T HRC 52-58	600
lunghezze - lengths			mm 510 - 250 - 550 fraz	

**USL 196/78° R1 E10W**

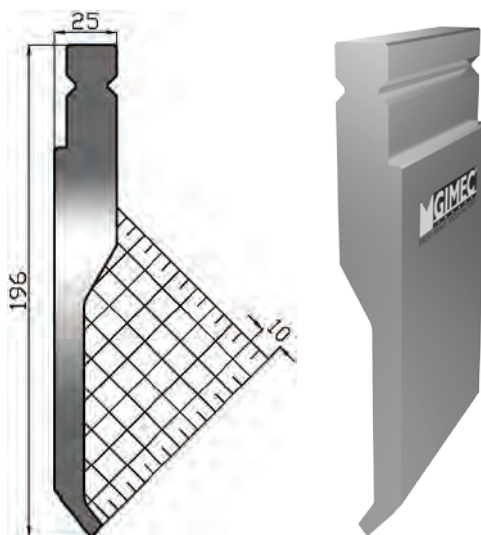

**USL 196/78° R2 E10W**

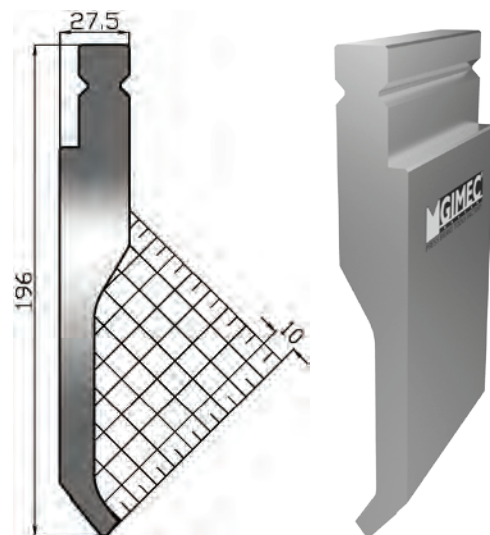

altezza height mm	angolo degree	raggio radius	acciaio steel	max kN/mt
196,0	78°	1,0	42CM4 T HRC 52-58	400
lunghezze - lengths			mm 510 - 250 - 550 fraz	

altezza height mm	angolo degree	raggio radius	acciaio steel	max kN/mt
196,0	78°	2,0	42CM4 T HRC 52-58	680
lunghezze - lengths			mm 510 - 250 - 550 fraz	

serie USL®

STANDARD TOOLS

**USL 196/78° R1 D10W**

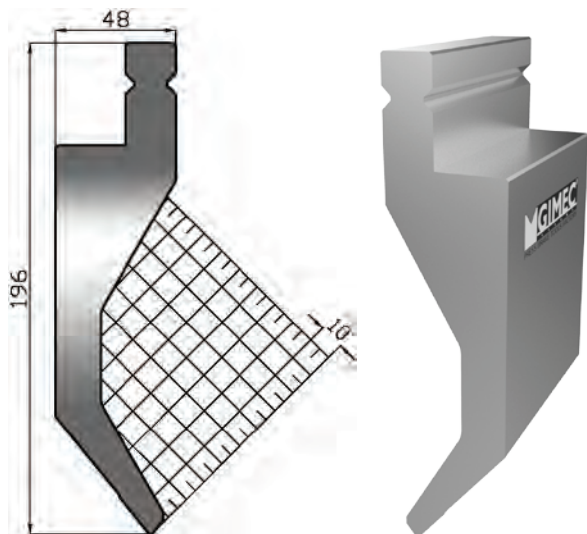

altezza height mm	angolo degree	raggio radius	acciaio steel	max kN/mt
196,0	78°	1,0	42CM4 T HRC 52÷58	400
lunghezze - lengths		mm 510 - 250 - 550 fraz		

**USL 196/78° R2 D10W**

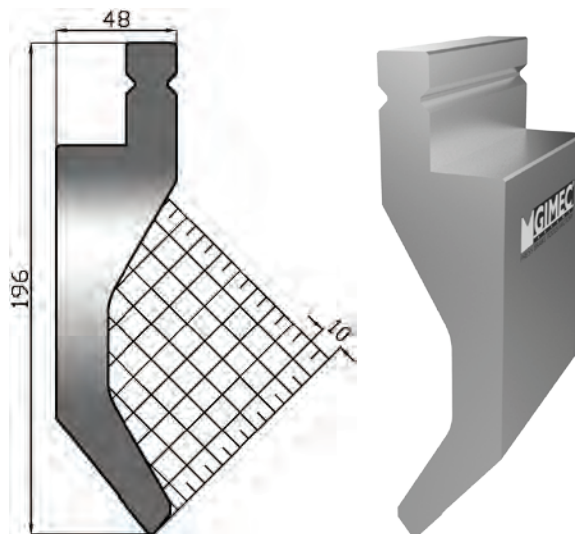

altezza height mm	angolo degree	raggio radius	acciaio steel	max kN/mt
196,0	78°	2,0	42CM4 T HRC 52÷58	750
lunghezze - lengths		mm 510 - 250 - 550 fraz		

**USL 196/26° R2 R10W**

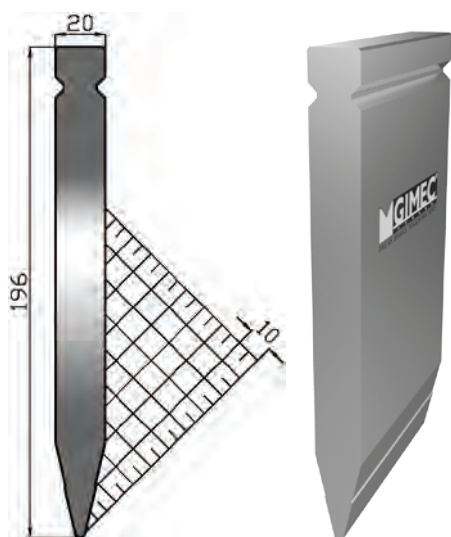

altezza height mm	angolo degree	raggio radius	acciaio steel	max kN/mt
196,0	26°	2,0	42CM4 T HRC 52÷58	800
lunghezze - lengths		mm 510 - 250 - 550 fraz		

**LUNGHEZZE - LENGTHS mm 510 - 250  
fraz 550 mm.25+30+35+40+45+50+100L+100R+125**

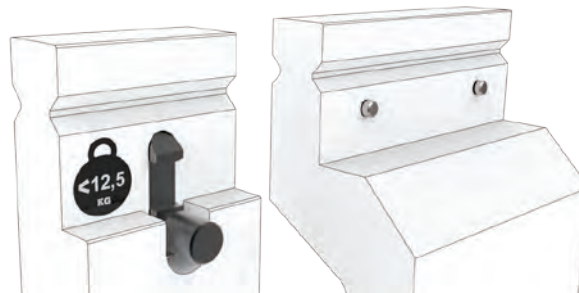
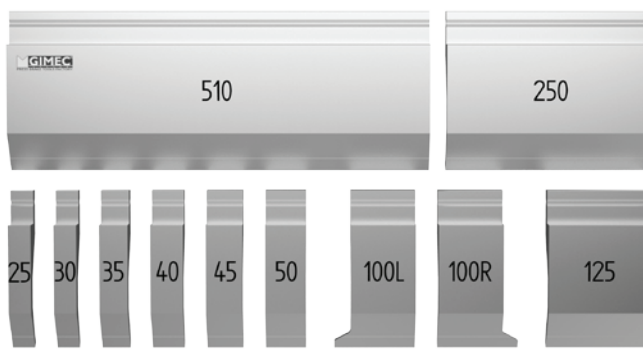

Gli utensili con peso inferiore a 12,5 kg vengono forniti con singolo o doppio pulsante. Oltre tale peso l'utensile viene fornito con spine. Tools with a weight less than 12,5 kg are supplied with a single or double push buttons. Beyond such weight the tool is supplied with pins.

serie **USL**®

STANDARD TOOLS

**USL 231/26° R1 J15W**

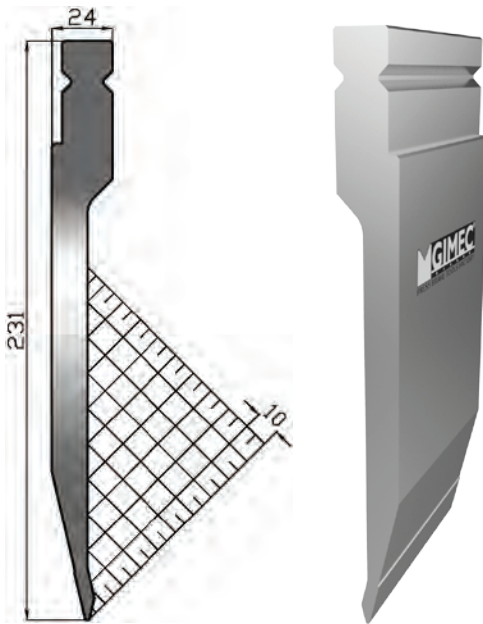

altezza height mm	angolo degree	raggio radius	acciaio steel	max kN/mt
231,0	26°	1,0	42CM4 T HRC 52-58	400
lunghezze - lengths		mm 510 - 250 - 550 fraz		

**USL 231/26° R2 J15W**

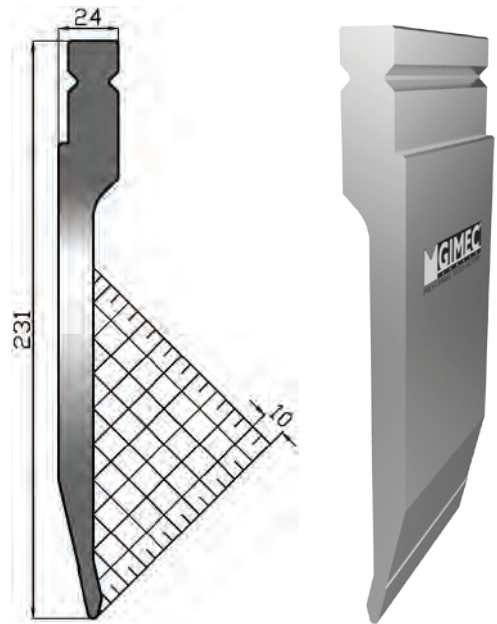

altezza height mm	angolo degree	raggio radius	acciaio steel	max kN/mt
231,0	26°	2,0	42CM4 T HRC 52-58	600
lunghezze - lengths		mm 510 - 250 - 550 fraz		

**USL 231/78° R1 E15W**

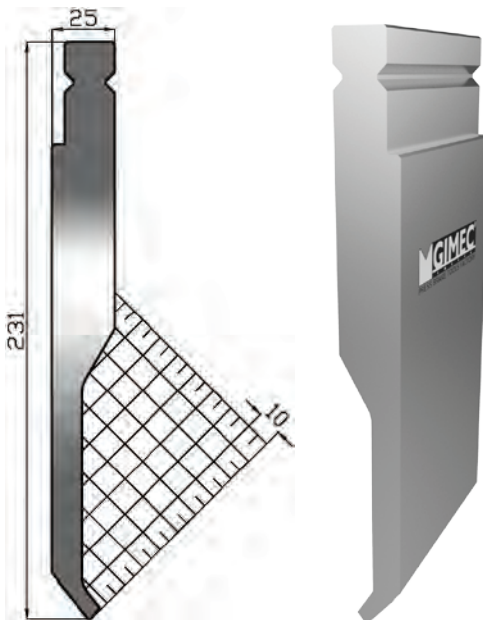

altezza height mm	angolo degree	raggio radius	acciaio steel	max kN/mt
231,0	78°	1,0	42CM4 T HRC 52-58	400
lunghezze - lengths		mm 510 - 250 - 550 fraz		

**USL 231/78° R2 E15W**

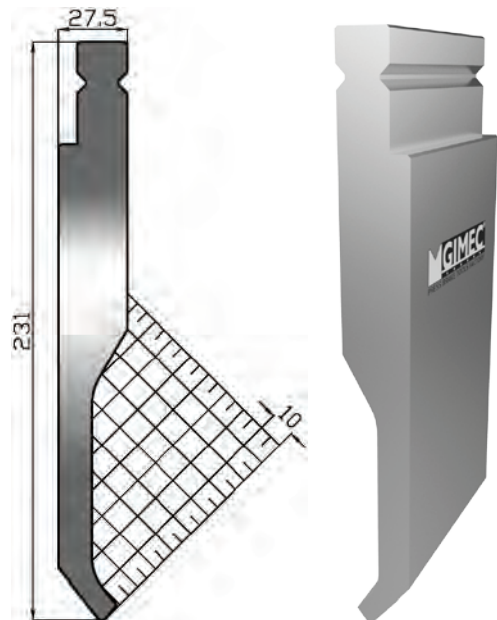

altezza height mm	angolo degree	raggio radius	acciaio steel	max kN/mt
231,0	78°	2,0	42CM4 T HRC 52-58	680
lunghezze - lengths		mm 510 - 250 - 550 fraz		

serie USL®

STANDARD TOOLS



**USL 231/78° R1 D15W**

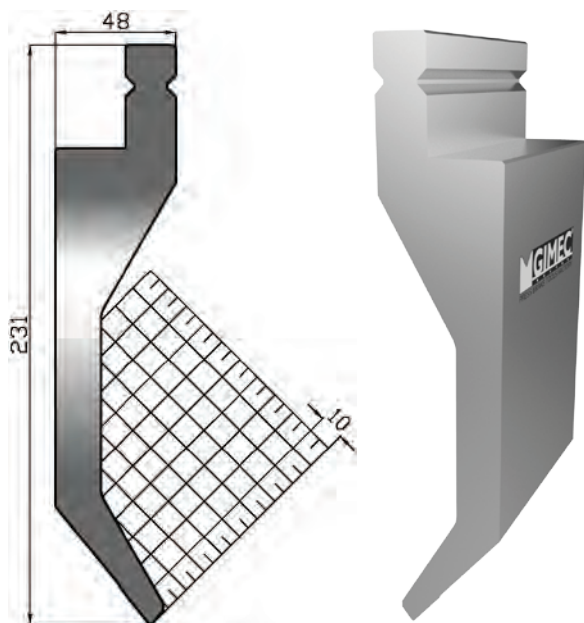

altezza height mm	angolo degree	raggio radius	acciaio steel	max kN/mt
231,0	78°	1,0	42CM4 T HRC 52÷58	400
lunghezze - lengths		mm 510 - 250 - 550 fraz		

**USL 231/78° R2 D15W**

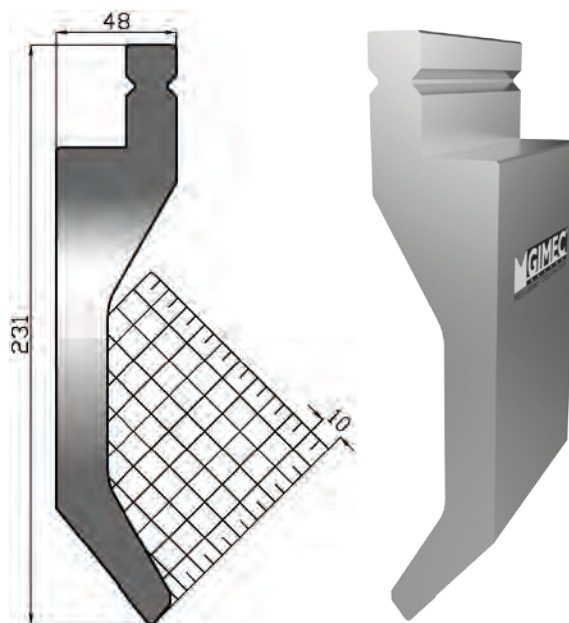

altezza height mm	angolo degree	raggio radius	acciaio steel	max kN/mt
231,0	78°	2,0	42CM4 T HRC 52÷58	750
lunghezze - lengths		mm 510 - 250 - 550 fraz		

**USL 231/26° R3 R15W**

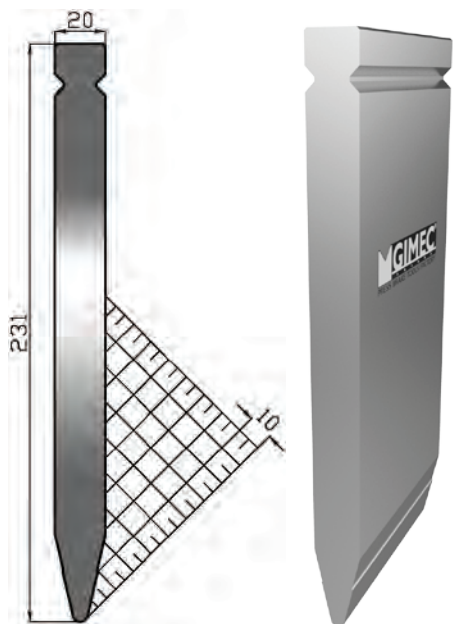

altezza height mm	angolo degree	raggio radius	acciaio steel	max kN/mt
231,0	26°	3,0	42CM4 T HRC 52÷58	1200
lunghezze - lengths		mm 510 - 250 - 550 fraz		

**LUNGHEZZE - LENGTHS mm 510 - 250  
fraz 550 mm.25+30+35+40+45+50+100L+100R+125**

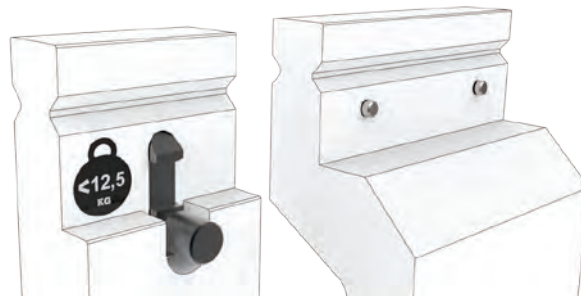
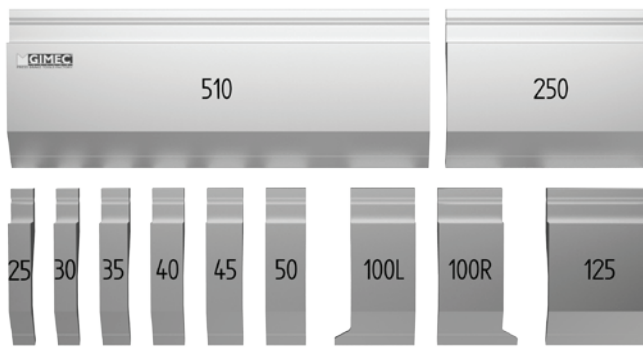

Gli utensili con peso inferiore a 12,5 kg vengono forniti con singolo o doppio pulsante. Oltre tale peso l'utensile viene fornito con spine. Tools with a weight less than 12,5 kg are supplied with a single or double push buttons. Beyond such weight the tool is supplied with pins.

serie **USL**®

STANDARD TOOLS

**USL 180/26° R1 J10**

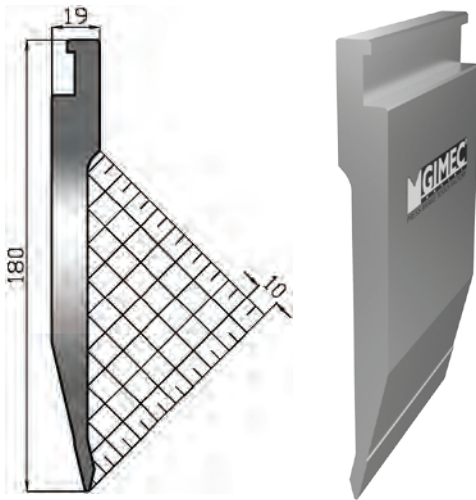

**USL 180/26° R2 J10**

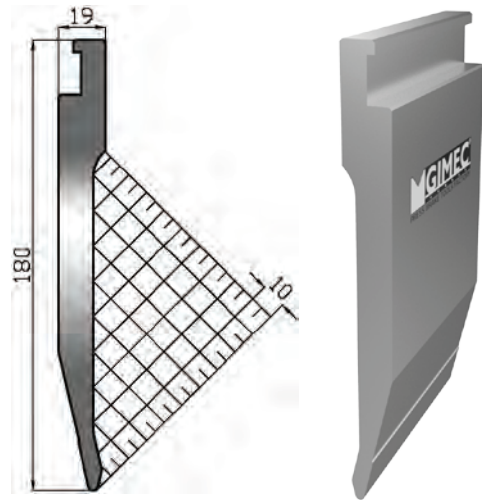

altezza height mm	angolo degree	raggio radius	acciaio steel	max kN/mt
180,0	26°	1,0	42CM4 T HRC 52-58	400
lunghezze - lengths		mm 510 - 250 - 550 fraz		

altezza height mm	angolo degree	raggio radius	acciaio steel	max kN/mt
180,0	26°	2,0	42CM4 T HRC 52-58	600
lunghezze - lengths		mm 510 - 250 - 550 fraz		

**USL 180/78° R1 E10**

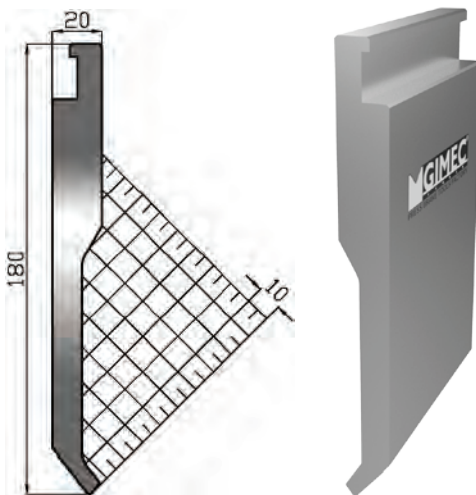

**USL 180/78° R2 E10**

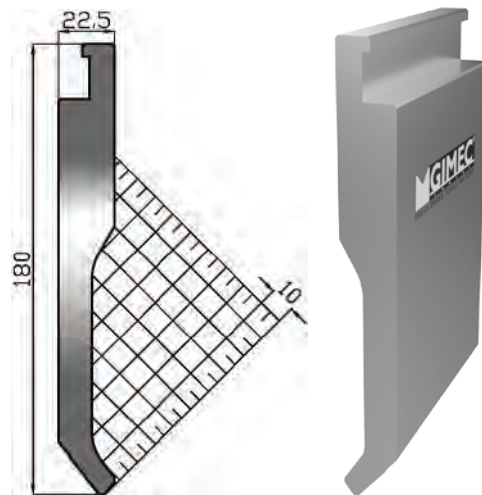

altezza height mm	angolo degree	raggio radius	acciaio steel	max kN/mt
180,0	78°	1,0	42CM4 T HRC 52-58	400
lunghezze - lengths		mm 510 - 250 - 550 fraz		

altezza height mm	angolo degree	raggio radius	acciaio steel	max kN/mt
180,0	78°	2,0	42CM4 T HRC 52-58	680
lunghezze - lengths		mm 510 - 250 - 550 fraz		

serie USL®

STANDARD TOOLS

**USL 180/78° R1 D10**

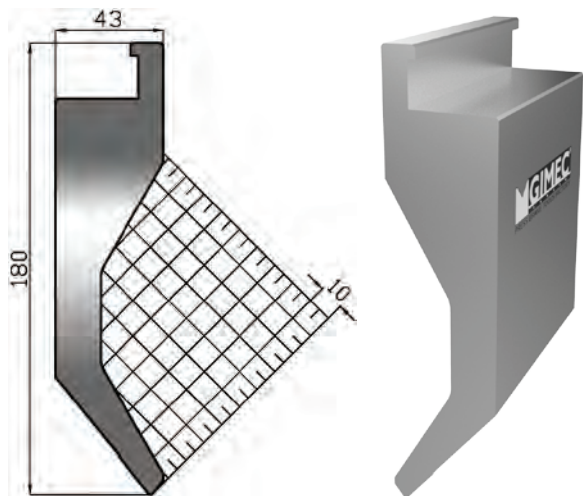

altezza height mm	angolo degree	raggio radius	acciaio steel	max kN/mt
180,0	78°	1,0	42CM4 T HRC 52-58	400
lunghezze - lengths		mm 510 - 250 - 550 fraz		

**USL 180/78° R2 D10**

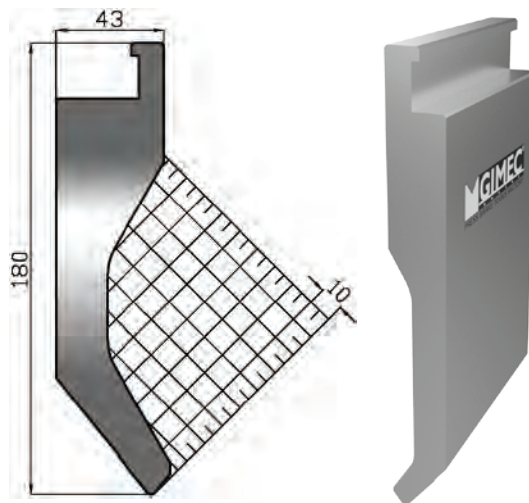

altezza height mm	angolo degree	raggio radius	acciaio steel	max kN/mt
180,0	78°	2,0	42CM4 T HRC 52-58	750
lunghezze - lengths		mm 510 - 250 - 550 fraz		

**USL 180/26° R2 R10**

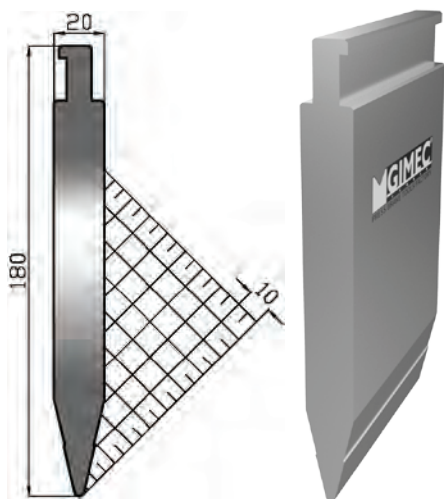

altezza height mm	angolo degree	raggio radius	acciaio steel	max kN/mt
180,0	26°	2,0	42CM4 T HRC 52-58	800
lunghezze - lengths		mm 510 - 250 - 550 fraz		

**LUNGHEZZE - LENGTHS mm 510 - 250  
fraz 550 mm.25+30+35+40+45+50+100L+100R+125**

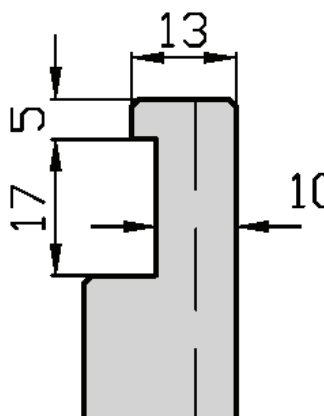
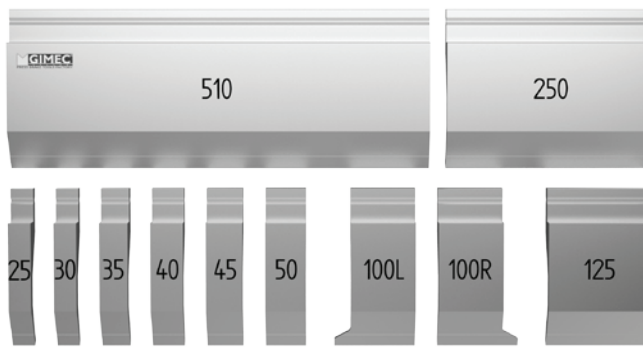

serie **USL**®

STANDARD TOOLS

**USL 225/26° R1 J15**

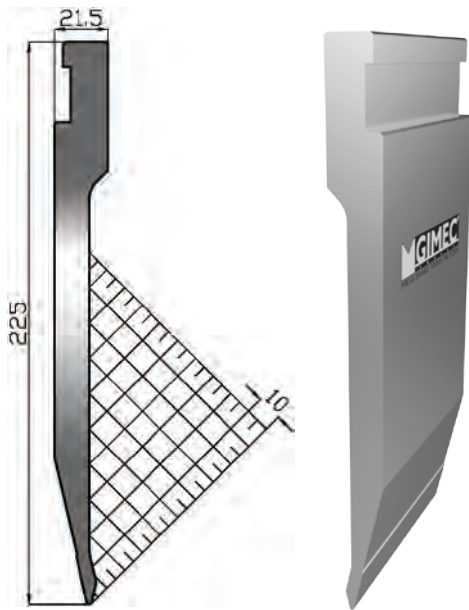

altezza height mm	angolo degree	raggio radius	acciaio steel	max kN/mt
225,0	26°	1,0	42CM4 T HRC 52-58	400
lunghezze - lengths		mm 510 - 250 - 550 fraz		

**USL 225/26° R2 J15**

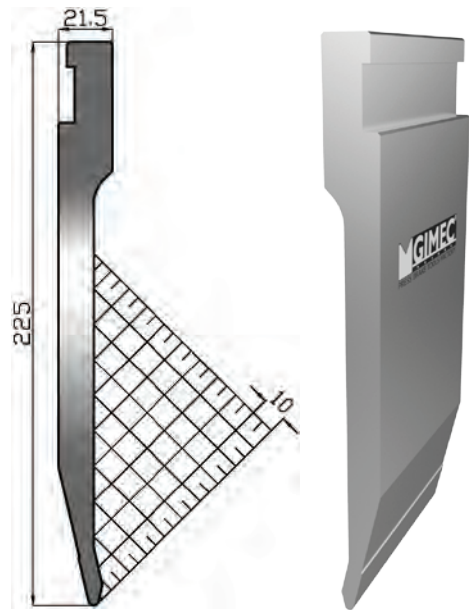

altezza height mm	angolo degree	raggio radius	acciaio steel	max kN/mt
225,0	26°	2,0	42CM4 T HRC 52-58	600
lunghezze - lengths		mm 510 - 250 - 550 fraz		

**USL 225/78° R1 E15**

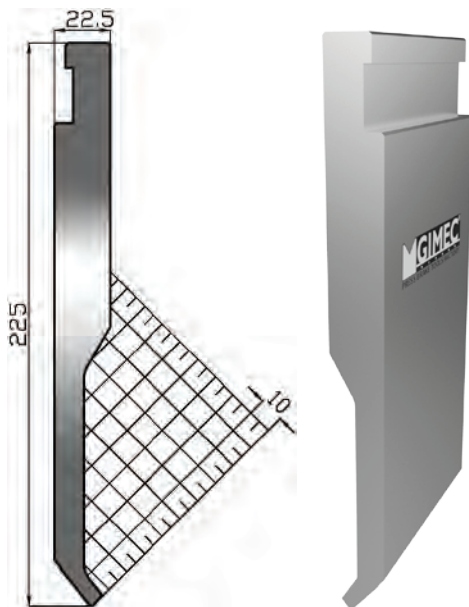

altezza height mm	angolo degree	raggio radius	acciaio steel	max kN/mt
225,0	78°	1,0	42CM4 T HRC 52-58	400
lunghezze - lengths		mm 510 - 250 - 550 fraz		

**USL 225/78° R2 E15**

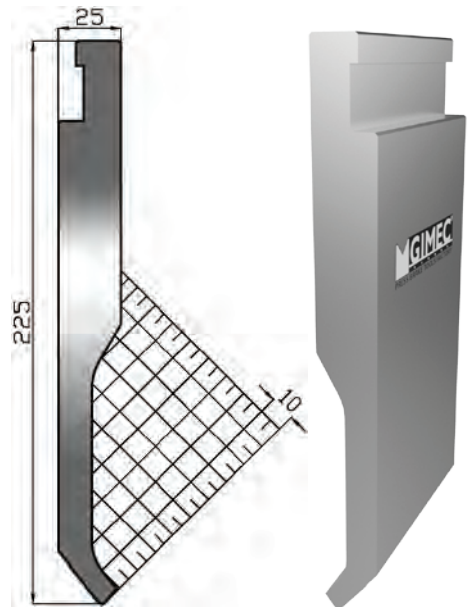

altezza height mm	angolo degree	raggio radius	acciaio steel	max kN/mt
225,0	78°	2,0	42CM4 T HRC 52-58	680
lunghezze - lengths		mm 510 - 250 - 550 fraz		

serie USL®

STANDARD TOOLS

**USL 225/78° R1 D15**

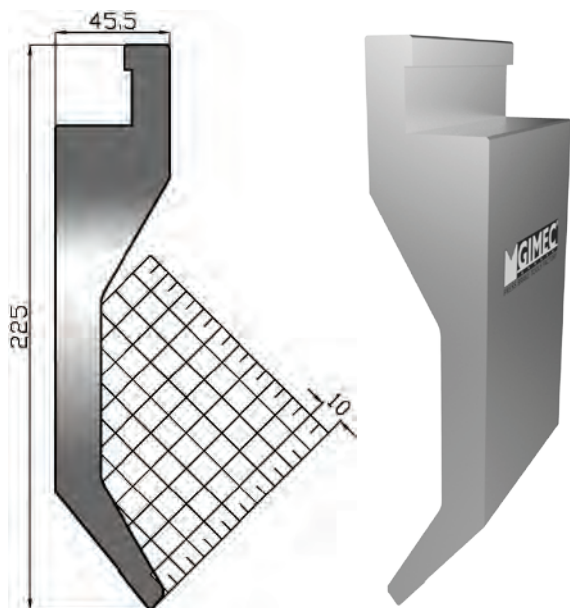

altezza height mm	angolo degree	raggio radius	acciaio steel	max kN/mt
225,0	78°	1,0	42CM4 T HRC 52÷58	400
lunghezze - lengths		mm 510 - 250 - 550 fraz		

**USL 225/78° R2 D15**

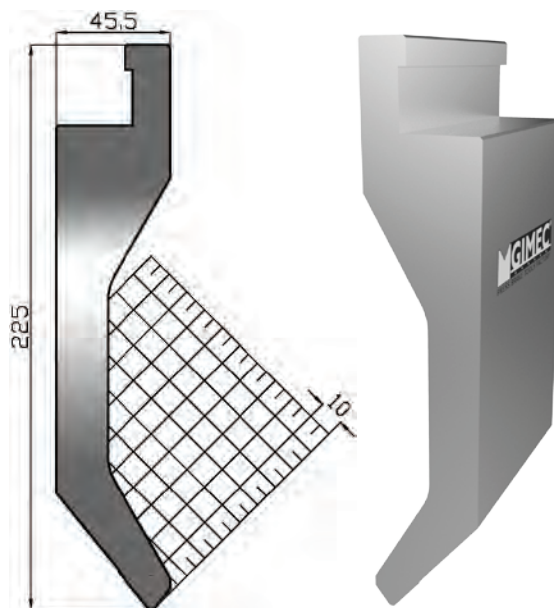

altezza height mm	angolo degree	raggio radius	acciaio steel	max kN/mt
225,0	78°	2,0	42CM4 T HRC 52÷58	750
lunghezze - lengths		mm 510 - 250 - 550 fraz		

**USL 225/26° R3 R15**

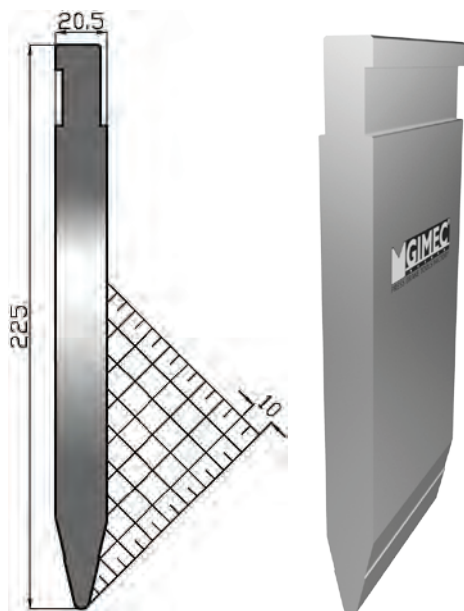

altezza height mm	angolo degree	raggio radius	acciaio steel	max kN/mt
225,0	26°	3,0	42CM4 T HRC 52÷58	1200
lunghezze - lengths		mm 510 - 250 - 550 fraz		

**LUNGHEZZE - LENGTHS mm 510 - 250  
fraz 550 mm.25+30+35+40+45+50+100L+100R+125**

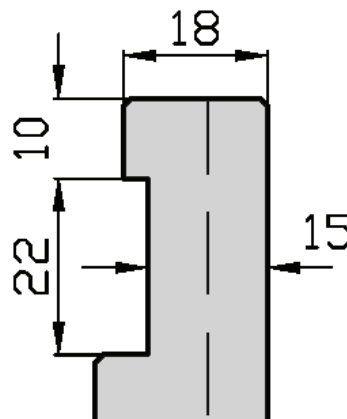
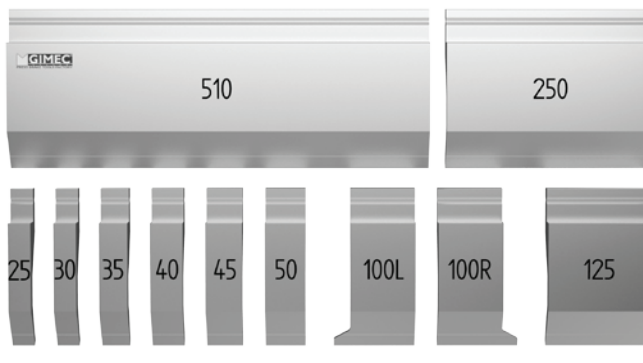

serie **USL**®

STANDARD TOOLS

serie **USL**®

USLP10W 8				USLP10W 10				USLP10W 12				USLP10 8				USLP10 10				USLP10 12			
altezza height		angolo degree		raggio radius		max kN/mt		altezza height		angolo degree		raggio radius		max kN/mt									
mm 206		20°		mm 1,0		400		mm 190		20°		mm 1,0		400									
acciaio - steel 42CM4 T HRC 52÷58																							
lunghezze - lengths mm 510 - 250 - 550 fraz																							

STANDARD TOOLS

USLP15W 8				USLP15W 10				USLP15W 12				USLP15 8				USLP15 10				USLP15 12			
altezza height		angolo degree		raggio radius		max kN/mt		altezza height		angolo degree		raggio radius		max kN/mt									
mm 251		20°		mm 1,0		400		mm 245		20°		mm 1,0		400									
acciaio - steel 42CM4 T HRC 52÷58																							
lunghezze - lengths mm 510 - 250 - 550 fraz																							

**USL 109/U 8** | **USL 109/U10** | **USL 109/U12** | **USL 149/U 8** | **USL 149/U10** | **USL 149/U12**

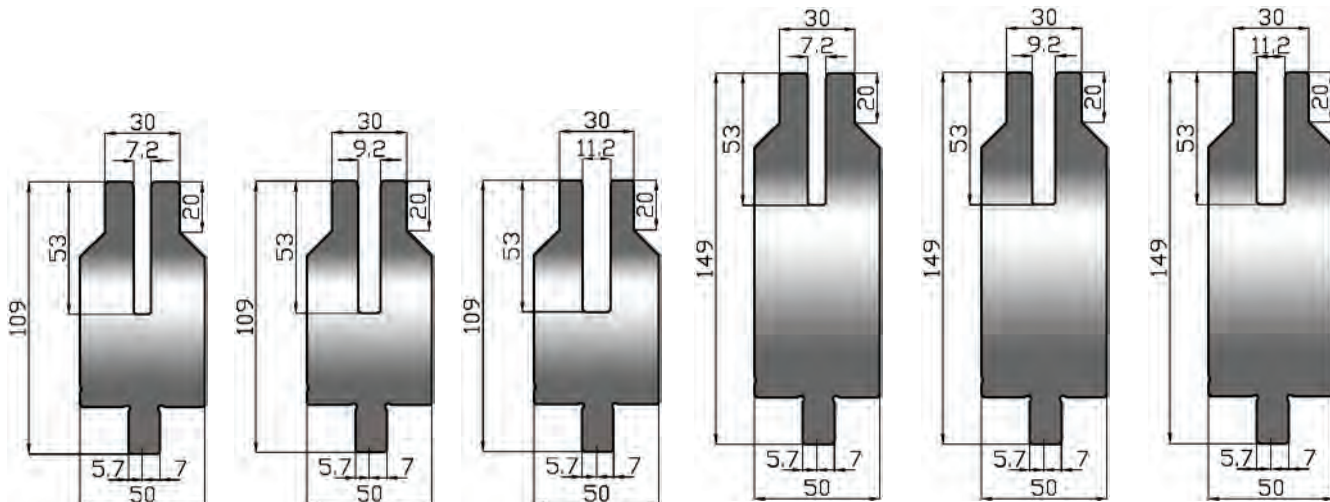

altezza height	V mm	raggio radius	max kN/mt
mm 109	8-10-12	mm 1,0	350
acciaio - steel 42CM4 T HRC 52÷58			
lunghezze - lengths mm 510 - 250 - 550 fraz			

altezza height	V mm	raggio radius	max kN/mt
mm 149	8-10-12	mm 1,0	350
acciaio - steel 42CM4 T HRC 52÷58			
lunghezze - lengths mm 510 - 250 - 550 fraz			



serie USL®

STANDARD TOOLS

**78°**

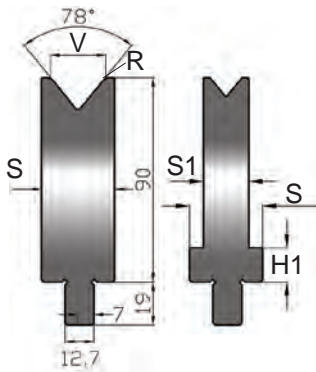

**STELO RETTIFICATO  
GROUND STEM**



codice articolo item code	V mm	R mm	H-H1 mm	S-S1 mm	max kN/mt
USL109 R/78° V06	6	1,0	90-15	32-12	400
USL109 R/78° V08	8	1,0	90-15	32-12	400
USL109 R/78° V10	10	1,0	90-15	32-14	500
USL109 R/78° V12	12	2,0	90-15	32-18	600
USL109 R/78° V16	16	2,5	90-15	32-25	800
USL109 R/78° V20	20	3,0	90	32	1000
USL109 R/78° V24	24	3,0	90	32	1000
USL109 R/78° V30	30	3,0	90	40	1100
USL109 R/78° V40	40	4,0	90	50	1300
USL109 R/78° V50	50	4,0	90	60	1500
USL109 R/78° V60	60	4,0	90	70	1500
USL109 R/78° V80	80	5,0	90	90	1500
USL109 R/78° V100	100	8,0	90	120	1200

acciaio - steel	42CM4 T HRC 52÷58	lunghezze - lengths	mm 510 - 250 - fraz 550
-----------------	-------------------	---------------------	-------------------------

**78°**

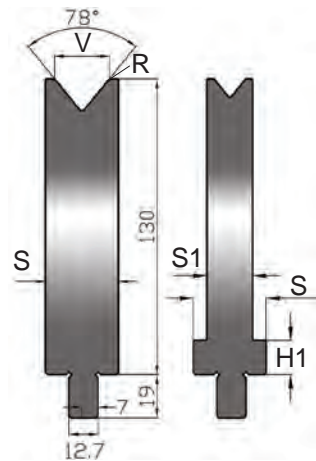

**STELO RETTIFICATO  
GROUND STEM**



codice articolo item code	V mm	R mm	H-H1 mm	S-S1 mm	max kN/mt
USL149 R/78° V06	6	1,0	130-15	32-12	400
USL149 R/78° V08	8	1,0	130-15	32-12	400
USL149 R/78° V10	10	1,0	130-15	32-14	500
USL149/ R78° V12	12	2,0	130-15	32-18	600
USL149 R/78° V16	16	2,5	130-15	32-25	800
USL149 R/78° V20	20	3,0	130	32	1000
USL149 R/78° V24	24	3,0	130	32	1000
USL149 R/78° V30	30	3,0	130	40	1100
USL149 R/78° V40	40	4,0	130	50	1300
USL149 R/78° V50	50	4,0	130	70	1500
USL149 R/78° V60	60	4,0	130	70	1500
USL149 R/78° V80	80	5,0	130	95	1500

acciaio - steel	42CM4 T HRC 52÷58	lunghezze - lengths	mm 510 - 250 - fraz 550
-----------------	-------------------	---------------------	-------------------------

**60°**



**STELO RETTIFICATO  
GROUND STEM**



codice articolo item code	V mm	R mm	H-H1 mm	S-S1 mm	max kN/mt
USL149 R/60° V30	30	4	30	40	500
USL149 R/60° V40	40	5	40	55	660
USL149 R/60° V50	50	5	50	70	1050
USL149 R/60° V60	60	5	60	80	1200
USL149 R/60° V80	80	6	80	102	1750
USL149 R/60° V100	100	8	100	120	1600
USL149 R/60° V120	120	8	120	145	1300

acciaio - steel	42CM4 T HRC 52÷58	lunghezze - lengths	mm 510 - 250 - fraz 550
-----------------	-------------------	---------------------	-------------------------

STANDARD TOOLS serie 12,7 USL®



<b>30°</b>		codice articolo item code	V mm	R mm	H-H1 mm	S-S1 mm	max kN/mt
 <p style="color: #008000; text-align: center;"><i>STELO RETTIFICATO GROUND STEM</i></p>		USL109 R/30° V06	6	0,8	90-15	32-16	200
		USL109 R/30° V08	8	1,0	90-15	32-18	220
		USL109 R/30° V10	10	1,2	90-15	32-25	300
		USL109 R/30° V12	12	1,6	90	32	380
		USL109 R/30° V16	16	3,0	90	32	380
		USL109 R/30° V20	20	3,0	90	40	380
		USL109 R/30° V24	24	3,0	90	50	550
		acciaio - steel		42CM4 T HRC 52÷58		lunghezze - lengths	

<b>30°</b>		codice articolo item code	V mm	R mm	H-H1 mm	S-S1 mm	max kN/mt
 <p style="color: #008000; text-align: center;"><i>STELO RETTIFICATO GROUND STEM</i></p>		USL149 R/30° V06	6	0,8	130-15	32-16	200
		USL149 R/30° V08	8	1,0	130-15	32-18	220
		USL149 R/30° V10	10	1,2	130-15	32-25	300
		USL149 R/30° V12	12	1,6	130	32	380
		USL149 R/30° V16	16	3,0	130	40	380
		USL149 R/30° V20	20	3,0	130	40	380
		acciaio - steel		42CM4 T HRC 52÷58		lunghezze - lengths	

**LUNGHEZZE • LENGTHS**

mm 510 - 250 - fraz 550 mm 20+20+25+25+30+35+40+40+45+75+75+120

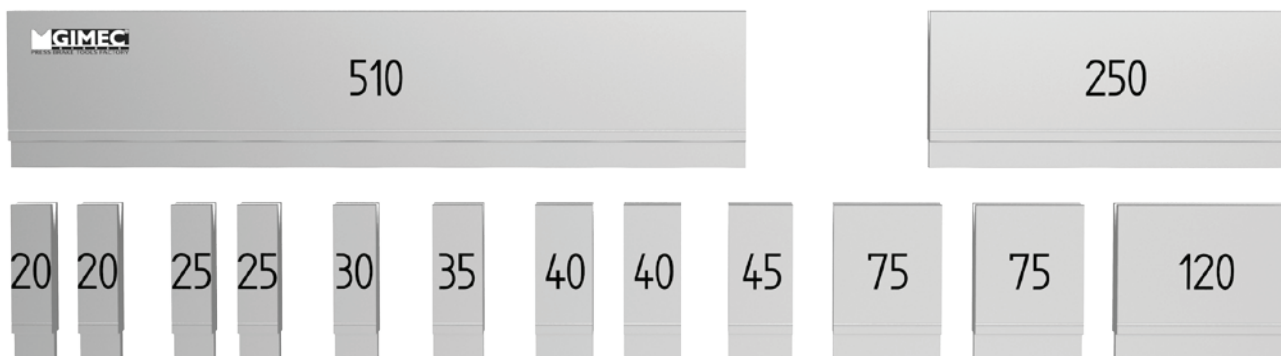

**serie 12,7 USL®**  
**STANDARD TOOLS**

**kN 300 - 600**

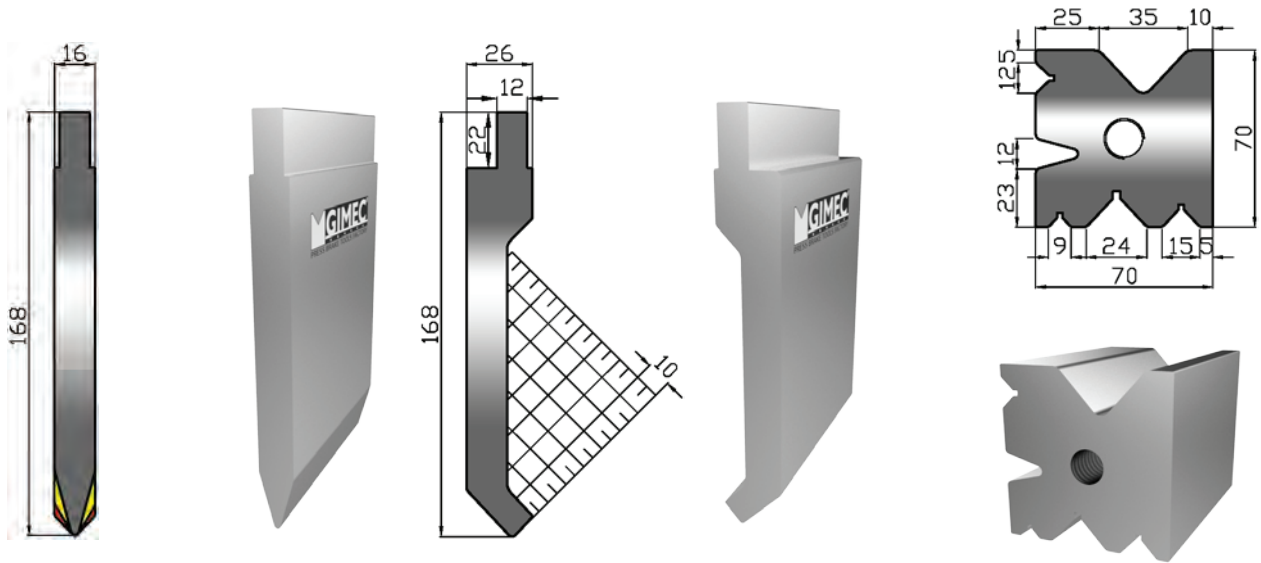

<b>USH 168</b>	<b>USH 168</b>	<b>USH M 70</b>
B=86° C=60° D=30° R1,5	A = 86° R1,5	V9-12-15-24-35/86°+V12/30°

**kN 1600 - 2800**

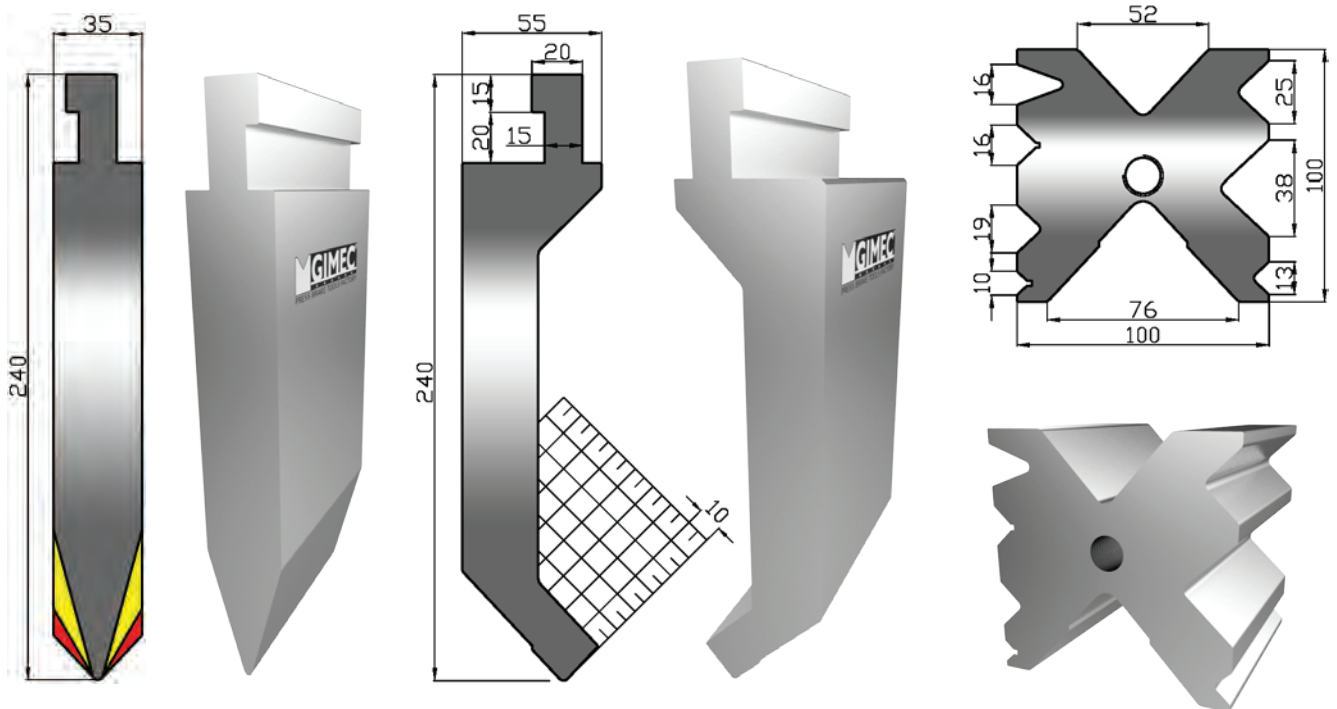

<b>USH 240</b>	<b>USH 240</b>	<b>USH M 100</b>
B=86° C=60° D=30° R2,0	A = 86° R2,0	V10-13-16-19-25-38-52-76/86°+V16/40°

**kN 800 - 1350**

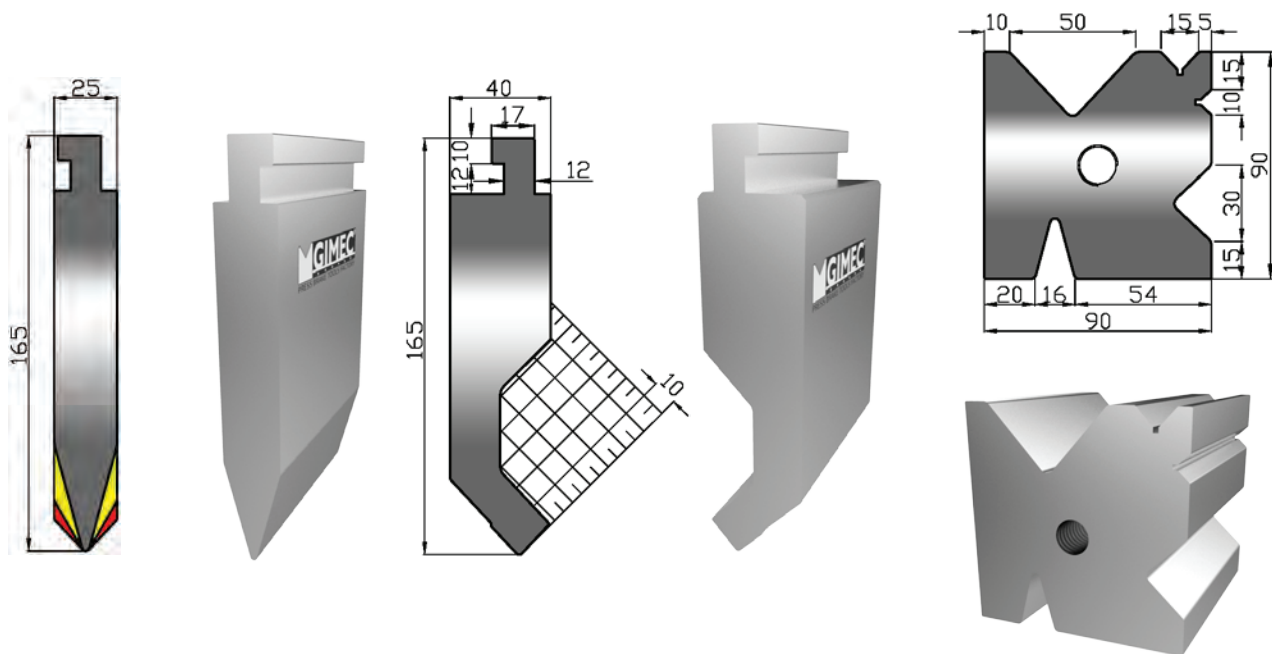

<b>USH 165</b>	<b>USH 165</b>	<b>USH M 90</b>
B=86° C=60° D=30° R1,5	A = 86° R1,5	V10-15-30-50/86°+V16/30°

**kN 3000 - 4000**

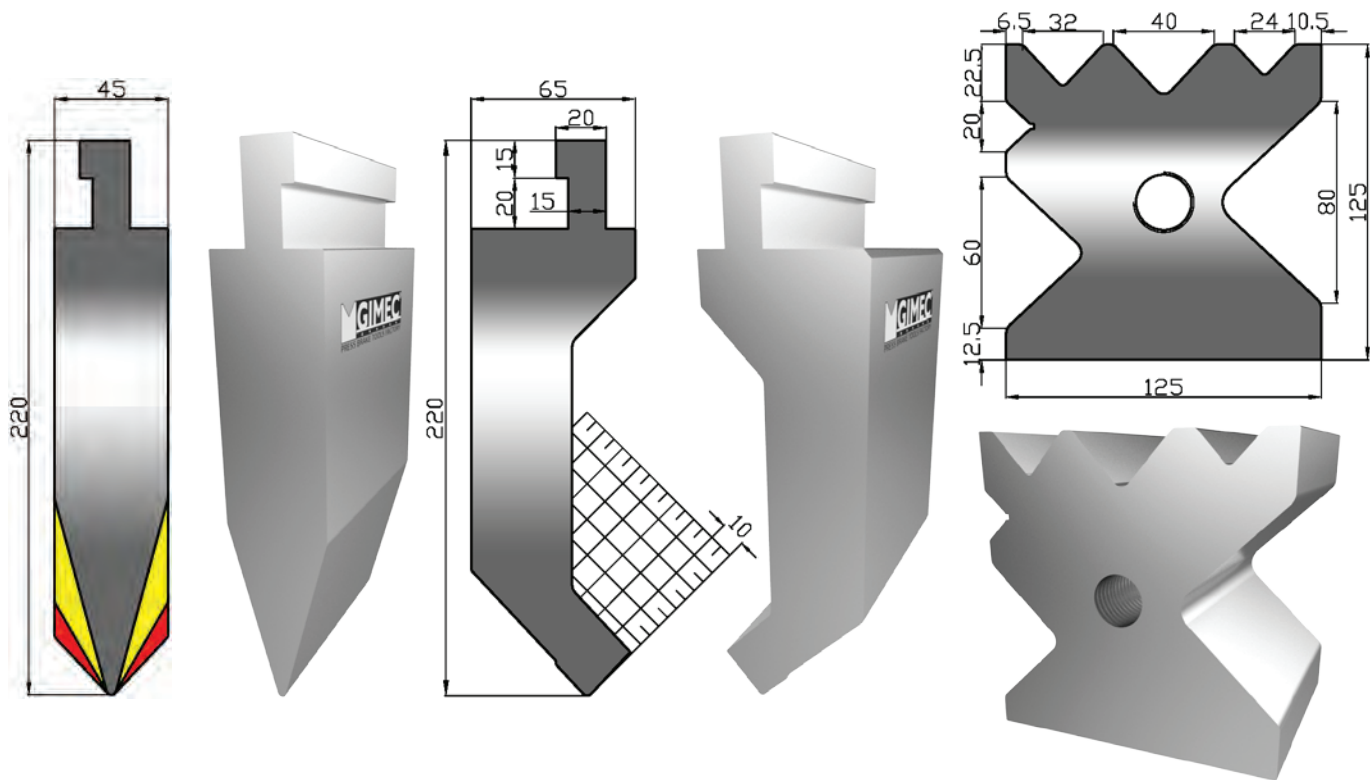

<b>USH 220</b>	<b>USH 220</b>	<b>USH M 125</b>
B=86° C=60° D=30° R2,0	A = 86° R2,0	V20-24-32-40-60-80/86°

**serie USH®**

**USC 195/26° R0,8**

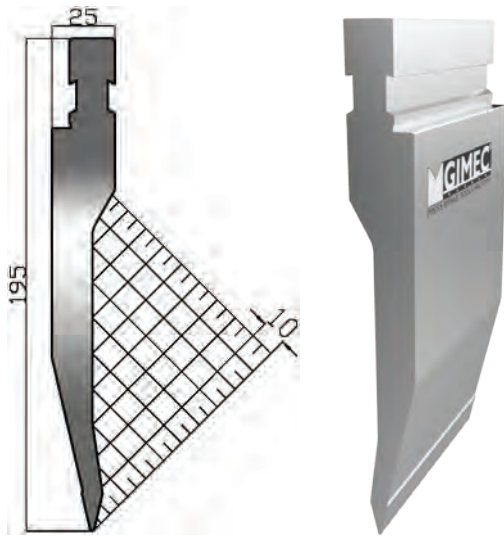

**USC 195/60° R0,8**

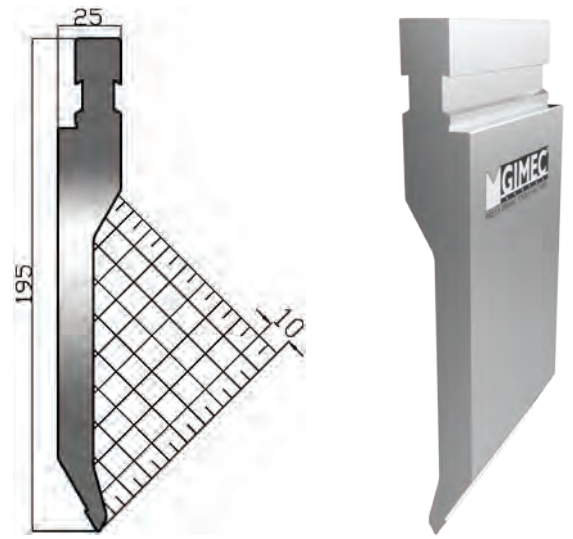

altezza height mm	angolo degree	raggio radius	acciaio steel	max kN/mt
195,0	26°	0,8	42CM4 T HRC 52-58	1000
lunghezze - lengths			mm 525 - fraz A - fraz B	

altezza height mm	angolo degree	raggio radius	acciaio steel	max kN/mt
195,0	60°	0,8	42CM4 T HRC 52-58	800
lunghezze - lengths			mm 525 - fraz A - fraz B	

**USC 195/85° R0,8**

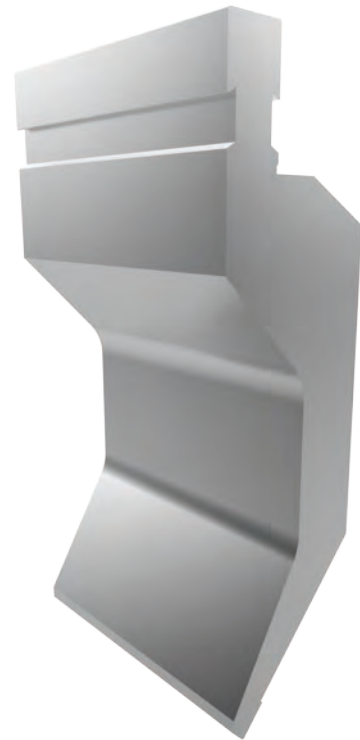
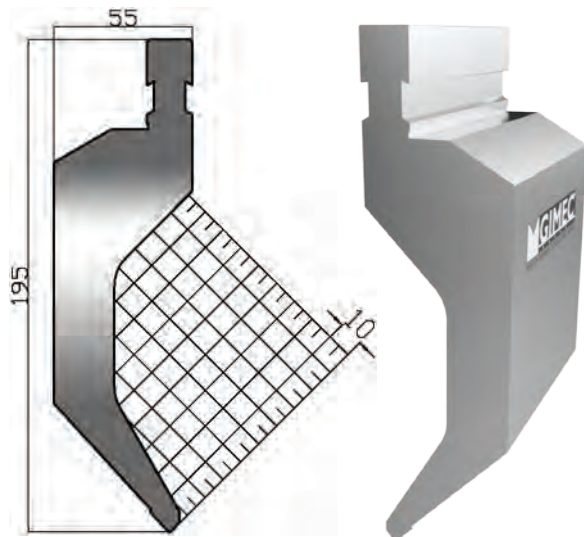

altezza height mm	angolo degree	raggio radius	acciaio steel	max kN/mt
195,0	85°	0,8	42CM4 T HRC 52-58	1000
lunghezze - lengths			mm 525 - fraz A - fraz B	

serie USC®

STANDARD TOOLS

**USC 180**

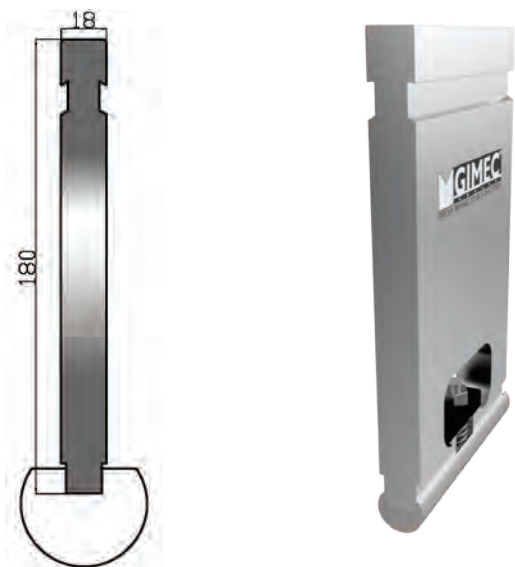

altezza - height mm	180
raggio-radius MIN - MAX	8 ÷ 50 mm
acciaio - steel	C45
lunghezze - lengths	mm 522
max kN/mt	500

**USC 305 R 8 ÷ 50 mm**

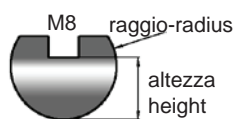

3 fori-holes mm 53,5-209-209-53,5 = mm 525

codice articolo item code	raggio radius	altezza height	codice articolo item code	raggio radius	altezza height
<b>USC 305/R 8</b>	8	10 mm	<b>USC 305/R 25</b>	25	29 mm
<b>USC 305/R 9</b>	9	10 mm	<b>USC 305/R 27,5</b>	27,5	34 mm
<b>USC 305/R 10</b>	10	12 mm	<b>USC 305/R 30</b>	30	34 mm
<b>USC 305/R 12,5</b>	12,5	17 mm	<b>USC 305/R 35</b>	35	45 mm
<b>USC 305/R 15</b>	15	20 mm	<b>USC 305/R 40</b>	40	44 mm
<b>USC 305/R 17,5</b>	17,5	22 mm	<b>USC 305/R 45</b>	45	50 mm
<b>USC 305/R 20</b>	20	24 mm	<b>USC 305/R 50</b>	50	54 mm
<b>USC 305/R 22,5</b>	22,5	25 mm			
acciaio - steel			C45 - 39NCM3 nitruato (N)		
lunghezze - lengths			mm 525		

**USC 310**

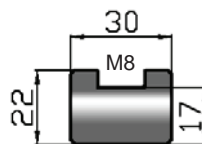

3 fori-holes mm 53,5-209-209-53,5 = mm 525

codice articolo item code	acciaio steel
<b>USC 310</b>	C45
<b>USC 310 T</b>	C45 T HRC 52-58
lunghezze - lengths	mm 525

**LUNGHEZZE • LENGTHS mm 525 - fraz A 495 mm - fraz B 500 mm**



**RVP 60-1**

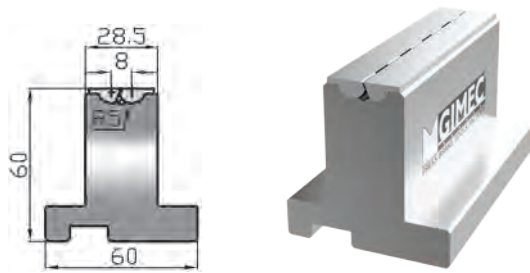

**RVS 80-1**

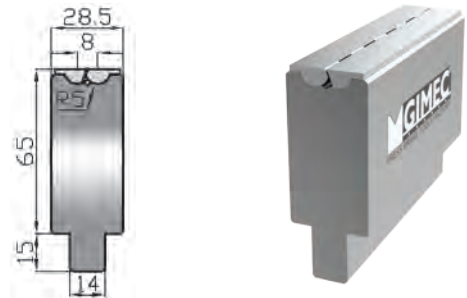

**RVT 55-1**

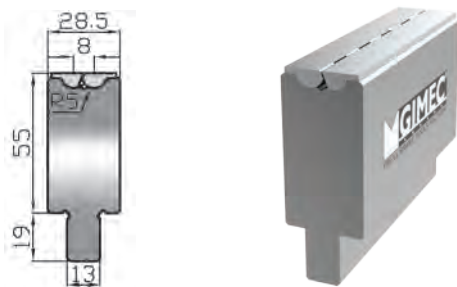

**RVT 90-1**

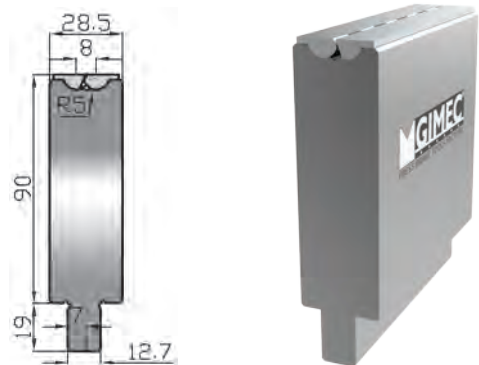

**RVT 100-1**

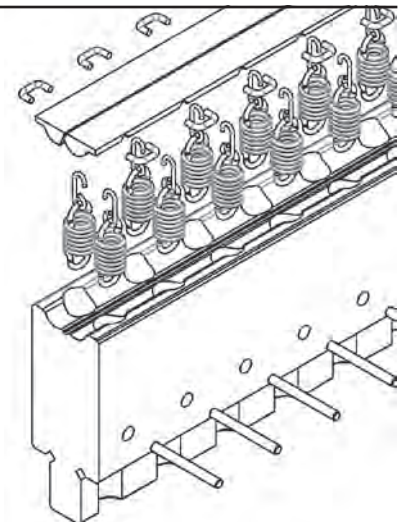
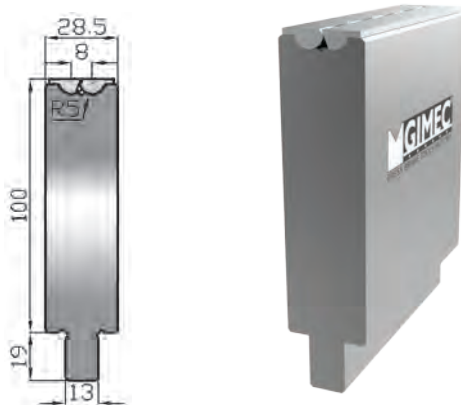

**ROLLA-V**®

**TIPO TYPE 1**

type 1 (rel.8)	max thickness mm	spessore thickness mm	angolo angle min.	bordo flange min. mm	max raggio est. out.radius	max raggio ut.sup radius up.tool	carico load max kN/mt	acciaio - steel
<b>V mm 8</b>	1,5	0,7	40°	5,1	3	2	1000	corpo / body 42CrMo4 nitr. HRC 53-55
		1,0	35°	5,1	2,7	1,5		
		1,5	35°	5,1	2,2	0,6		
lunghezze - lengths			mm 500 mm 440 fraz (mm 15-20-25-30-50-100-200)				inserti / inserts Toolox 44 HRC:44	

**RVP 65-2**

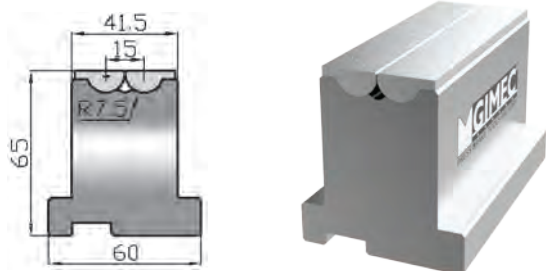

**RVS 80-2**

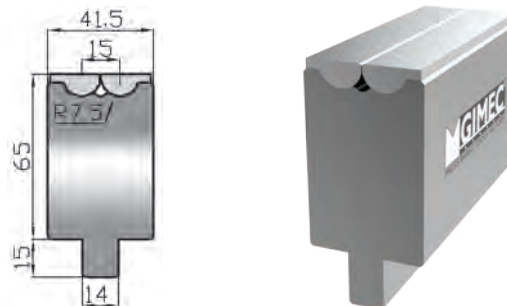

**RVT 60-2**

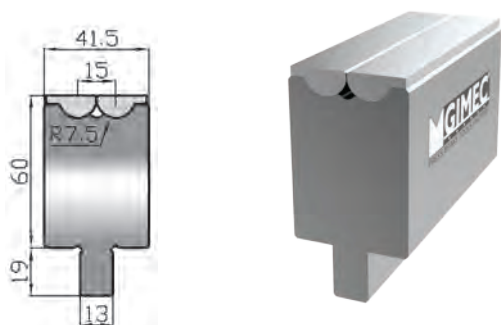

**RVT 90-2**

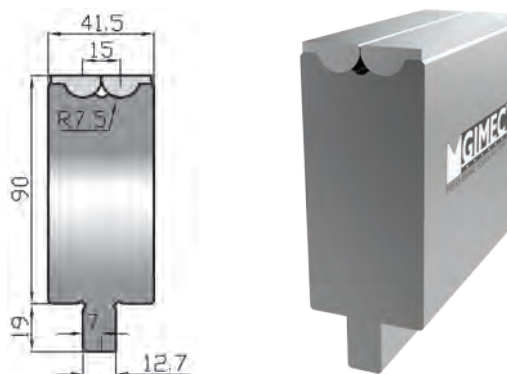

**RVT 100-2**

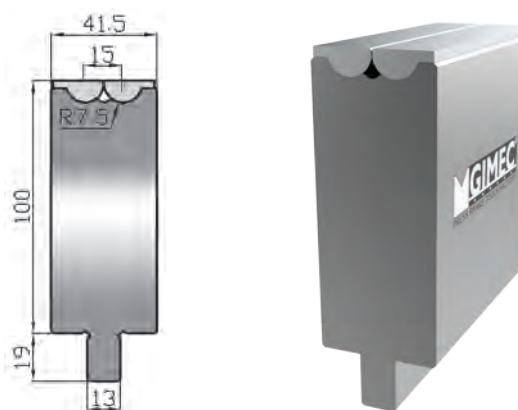

**ROLLA-V**®

**TIPO TYPE 2**

type 2 (rel.2)	max thickness mm	spessore thickness mm	angolo angle min.	bordo flange min. mm	max raggio est. out.radius	max raggio ut.sup radius up.tool	carico load max kN/mt	acciaio - steel
<b>V mm 15</b>	3,2	2,0	59°	9,8	6	3,6	1500	corpo / body 42CrMo4 nitr. HRC 53-55
		3,0	47°	9,8	5	1,8		
		3,2	47°	9,8	4,8	1,5		
lunghezze - lengths			mm 500 mm 450 fraz (mm 20-25-30-35-40-100-200)				inserti / inserts Toolox 44 HRC:44	

**RVM 100-2.5**

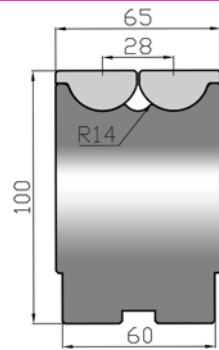

type 2.5 (rel.1)	max thickness mm	spessore thickness mm	angolo angle min.	bordo flange min. mm	max raggio est. out.radius	max raggio ut.sup radius up.tool	carico load max kN/mt	acciaio - steel	
<b>V mm 28</b>	6,0	2,0	46°	18,6	13,8	7,8	2500	corpo / body 42CrMo4 nitr. HRC 53-55  inserti / inserts Toolox 44 HRC:44	
		4,0	46°	18,6	11,8	6,2			
		6,0	55°	18,6	9,8	3			
lunghezze - lengths			mm 500 mm 470 fraz (mm 35-40-45-50-100-200)						

**RVP 100-3**

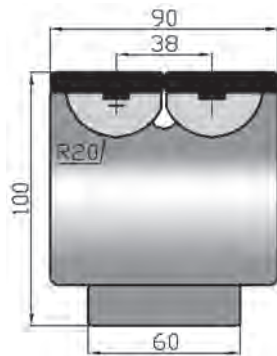

**RVM 70-3**

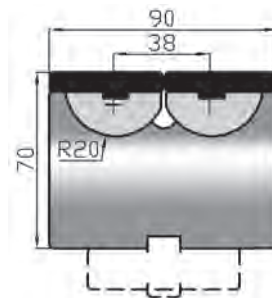

**RVT 100-3**

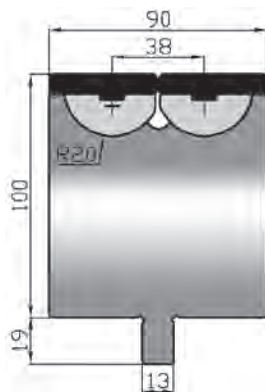

type 3 (rel.3)	max thickness mm	spessore thickness mm	angolo angle min.	bordo flange min. mm	max raggio est. out.radius	max raggio ut.sup radius up.tool	carico load max kN/mt	acciaio - steel	
<b>V mm 38</b>	6,0	2,0	68°	23,6	13,9	9,5	2500	corpo / body 42CrMo4 nitr. HRC 53-55 elementi tondi / round elements 42CrMo4 nitr. HRC 53-55 elementi piatti / flat elements Toolox 44 HRC:44	
		4,0	47°	23,6	11,9	6,3			
		6,0	50°	23,6	9,9	3,1			
lunghezze - lengths			mm 500 mm 455 fraz (mm 45-50-60-100-200)						

ROLLA-V®

TIPO TYPE 2,5 - 3



**RVM 90-4**

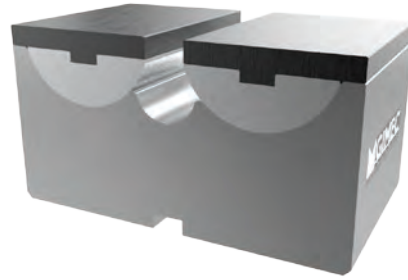
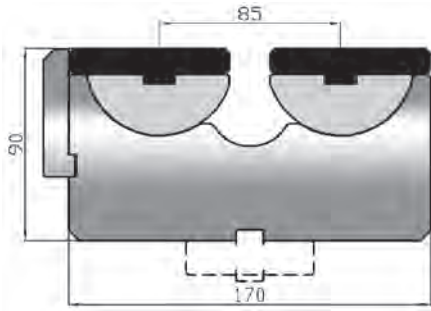

type 4 (rel.2)	max thickness mm	spessore thickness mm	angolo angle min.	bordo flange min. mm	max raggio est. out.radius	max raggio ut.sup radius up.tool	carico load max kN/mt	acciaio - steel
<b>V mm 85</b>	12,0	6,0	78°	56,6	42,1	28,9	3000	corpo / body 42CrMo4 nitr. HRC 53:55 elementi tondi / round elements 42CrMo4 nitr. HRC 53:55 elementi piatti / flat elements Toolox 44 HRC:44
		8,0	76°	56,6	40,1	25,7		
		12,0	73°	56,6	36,1	19,3		
lunghezze - lengths			mm 500		mm 250			

**ATTACCHI - CLAMPINGS**

**RVM 100-2.5 - RVM 70-3 - RVM 90-4**

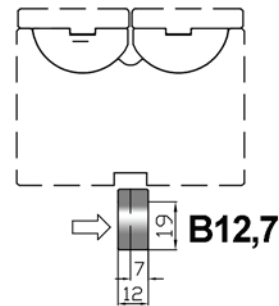
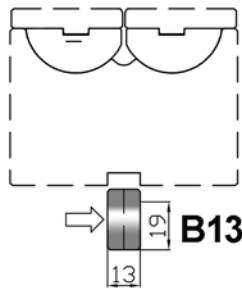
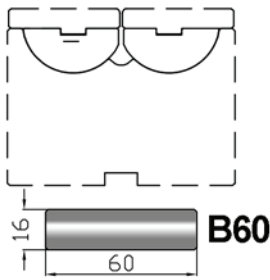

**TABELLA CALCOLO FORZA - FORCE CALCULATION TABLE**

<b>A</b> distanza dal centro di rotazione - rotor centre distance	<b>B</b> valore per calcolo bordo - value for calculating flange size (DNC)
<b>C</b> valore per calcolo tonnellaggio - value for calculating tonnages	<b>R</b> raggio cava - corner radius (DNC)

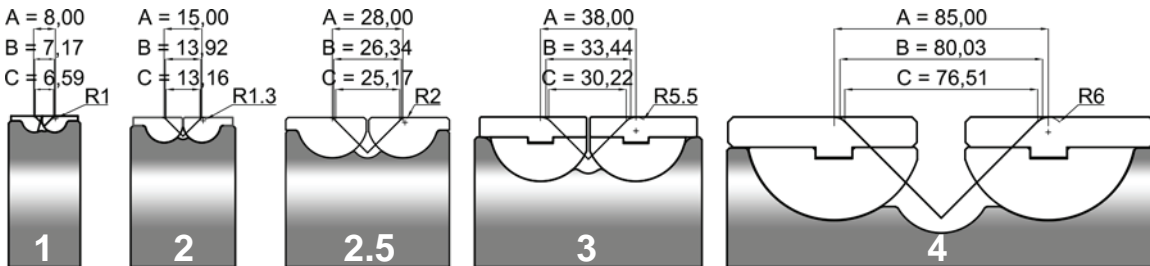

type 1 - V 8				type 2 - V 15				type 2.5 - V 28				type 3 - V 38				type 4 - V 85			
spes. thick. mm	resistenza lamiera sheet resistance N/mm <sup>2</sup>			spes. thick. mm	resistenza lamiera sheet resistance N/mm <sup>2</sup>			spes. thick. mm	resistenza lamiera sheet resistance N/mm <sup>2</sup>			spes. thick. mm	resistenza lamiera sheet resistance N/mm <sup>2</sup>			spes. thick. mm	resistenza lamiera sheet resistance N/mm <sup>2</sup>		
	200	450	700		200	450	700		200	450	700		200	450	700		200	450	700
0,7	21	48	74	2,0	97	219	341	3,0	106	238	370	2,0	33	75	117	6,0	124	278	433
1,0	49	110	171	3,0	260	586	911	4,0	208	468	728	4,0	162	364	567	8,0	237	534	830
1,5	130	294	457	3,2	306	688	1070	6,0	559	1257	1956	6,0	427	962	1496	12,0	613	1378	2144

**RVHD3**

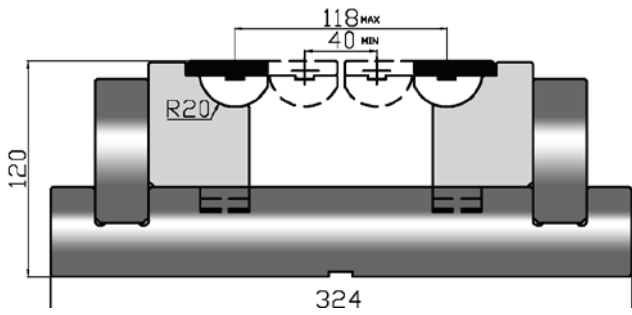

V mm	40 ÷ 118	max kN/mt	3500	lunghezze - lengths	mm 500 - 250
------	----------	-----------	------	---------------------	--------------

**RVPV4**

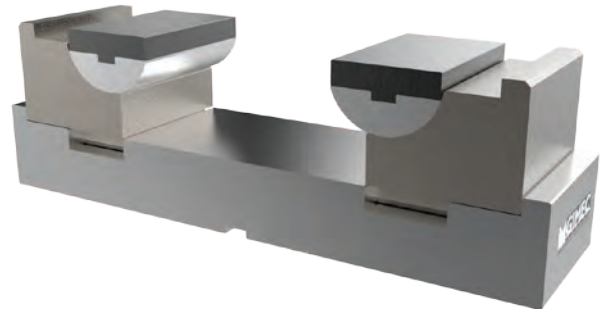
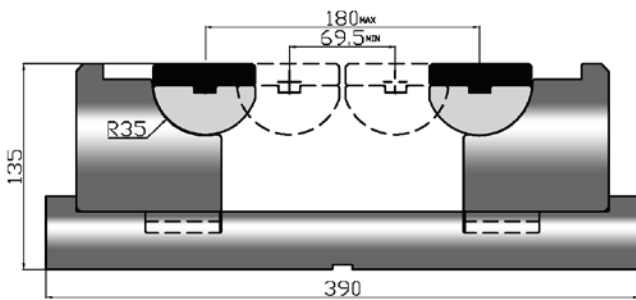

V mm	69,5÷180	max kN/mt	3000	lunghezze - lengths	mm 500 - 250
------	----------	-----------	------	---------------------	--------------



**ROLLA-V**®

**V - VARIABILE**

## CARATTERISTICHE TECNICHE - TECHNICAL FEATURES

L'uso delle matrici ROLLA-V ha i seguenti vantaggi:

- piegatura di bordi molti ridotti
- minimi segni di piegatura
- possibilità di eseguire pieghe vicine a fori ed asole, evitando deformazioni anche su parti di lamiera tagliate oblique.

Con i modelli a cava variabile si possono eseguire pieghe con forma ad "U" fino a 180°.

The use of ROLLA-V tools has the following advantages:

- very small edges
- minimum signs of bending
- allow to perform bends near holes and slots avoiding deformations, also, on oblique cut sheet parts.

With the ROLLA-V dies with variable slot, it is possible to perform "U" bends up 180°.

## SETUP UTENSILI - TOOLS SETUP

È essenziale che la linea centrale del ROLLA-V sia sulla stessa linea dell'utensile superiore.

Si consiglia di utilizzare un punzone con angolo 88° o similare per centrare la matrice.

La programmazione può essere effettuata indicando differenti larghezze della cava per ottenere l'angolo di piega desiderato. Non è necessario utilizzare l'intera lunghezza dell'utensile, ma in questi casi assicurarsi che il pezzo da piegare sia posizionato centralmente sulla matrice ROLLA-V.

The centerline of the ROLLA-V must be on the same centerline as the upper tool.

We recommend using an 88° or similar angle punch to help centralize the lower tool.

Programming can be by signaling different V widths to achieve the desired bend angle.

It is not necessary to use the entire length of the tool, but in such cases, ensure the component is centrally placed on the ROLLA-V die.

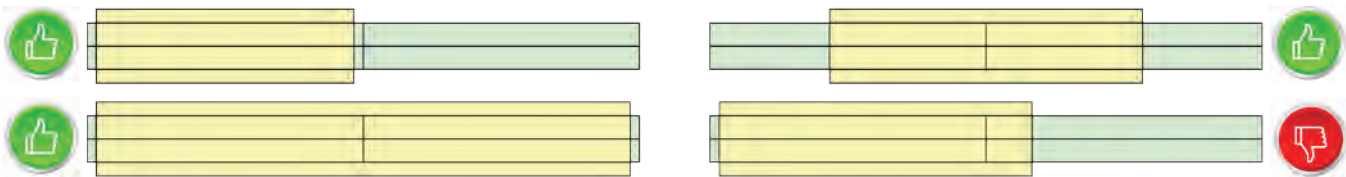

## MANUTENZIONE - MAINTENANCE

Assicurarsi che le superfici del raggio dell'utensile siano lubrificate con Molykote BR2 Plus o grasso simile. È necessaria solo una leggera lubrificazione. È importante che periodicamente (a seconda del materiale in lavorazione) l'utensile venga smontato, pulito e lubrificato nuovamente. (Vedere le istruzioni fornite per il montaggio / smontaggio)



Please ensure that the tool radius surfaces are lubricated with Molykote BR2 Plus or similar grease.

Only a light coating is necessary.

It is essential that periodically (dependent on the material being processed) the tool is stripped, cleaned, and re-greased.

(See the instructions provided for assembly / disassembly)

LS 60°

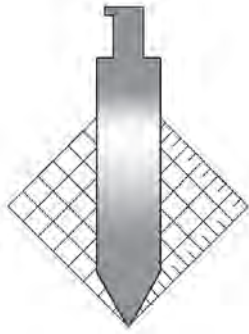

LS 30°

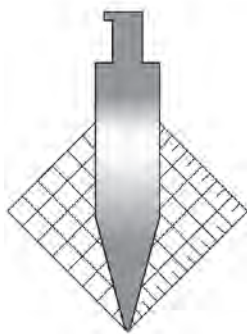

LD 60°

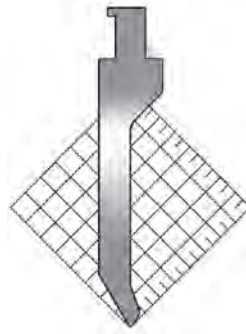

LDN 60°

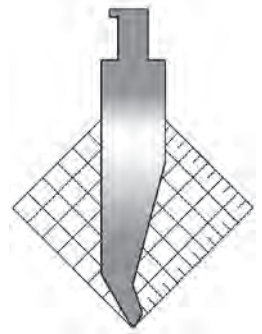

LX 30°

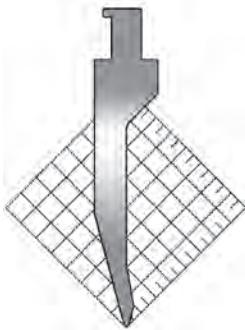

LDP 30°

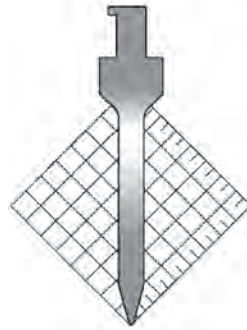

LDS 60°

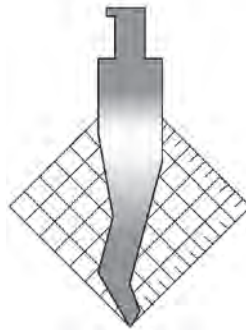

LUP 15°

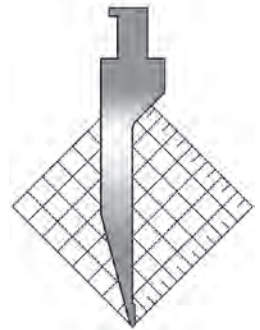

LSCC 84°

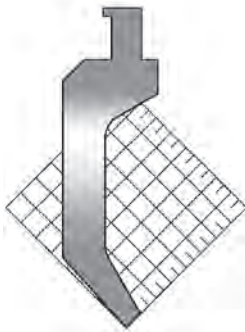

LSCC 60°

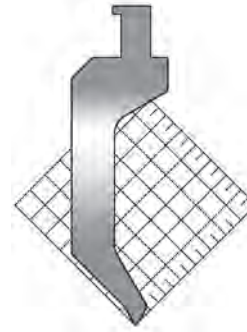

LSCZ 60°

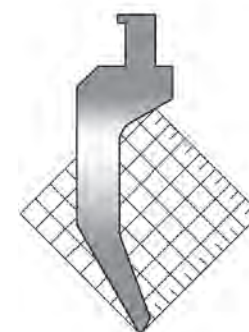

LSCY 60°

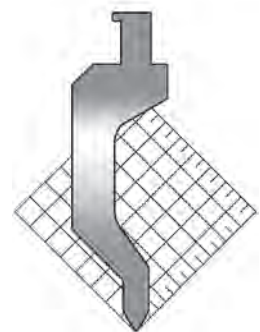

LCC 84°

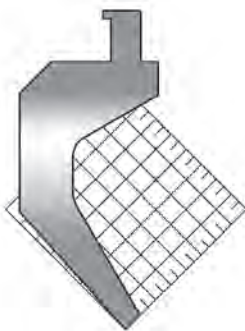

LCC 60°

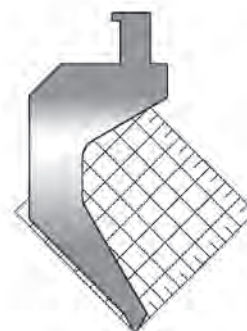

LCZ 60°

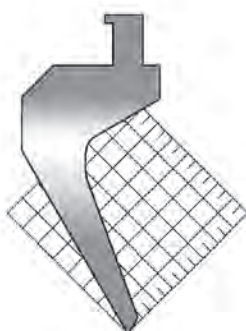

LCY 60°

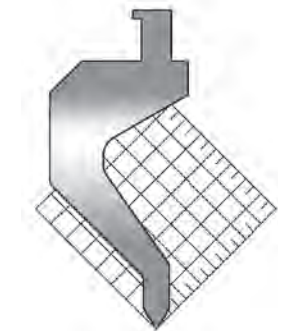

STAMPI

UPPER TOOLS

**M**

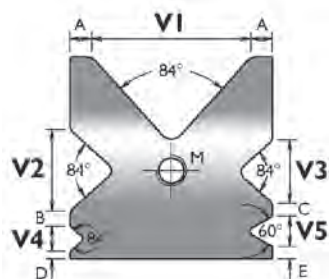

tipo type	dimensioni dimensions mm	84°				60°	A	B	C	D	E	M
		V1	V2	V3	V4	V5						
M 60	60 x 60	40	25	20	10	12	10	6	5	3	5	
M 70	70 x 70	50	32	25	10	12	10	6	5	3	5	M12
M 80	80 x 80	63	32	25	10	12	8,5	6	5	3	5	M12
M 90	90 x 90	70	40	25	10	12	10	6	5	3	5	M16
M 100	100 x 100	80	40	32	10	12	10	9	5	3	5	M16
M 110	110 x 110	90	50	32	10	12	10	9	5	3	5	M16
M 120	120 x 120	90	50	40	12	16	15	10	10	5	5	M16
M 130	130 x 130	110	50	40	12	16	10	10	10	5	5	M16
M 140	140 x 140	110	50	40	16	20	15	10	10	5	5	M20

**M1**

**M2**

**M3**

**M4**



**M5**

**M8**

**M9**

**M10**



**M11**

**M12**

**M13**

**M14**



STAMPI

LOWER TOOLS

M19



M20 A-B

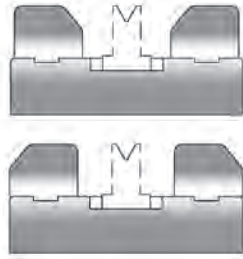

M16

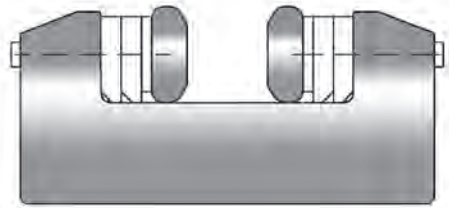

V-MUTABILIS matrice regolabile - adjustable die

carico-load max 4000 kN/mt

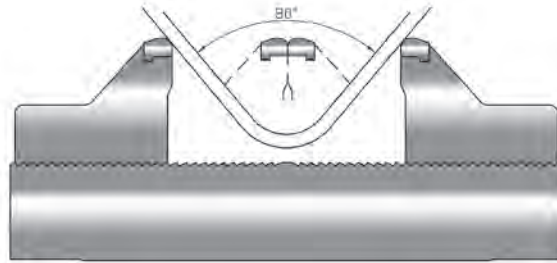

V mm 0 - 200 / 250 / 350 / 400

SP



SPD

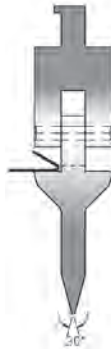

SPX



MP



MPS



SP1



SP2

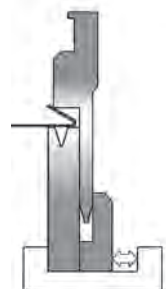

STAMPI

SPECIAL TOOLS

SP3 A

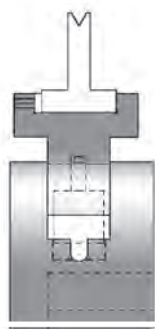

SP3 B



SP3 C



DUO

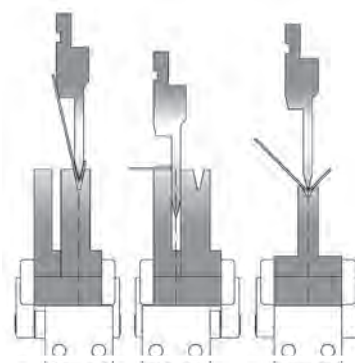

SP4



SP5



SP6

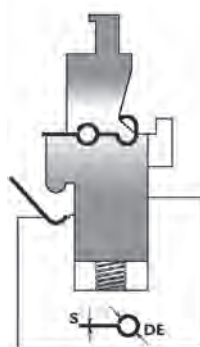

SP7

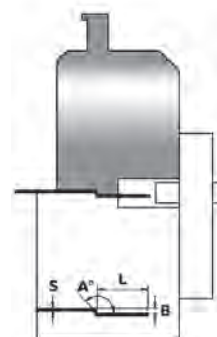

SP8



SP9



SP10



SP11



SP12

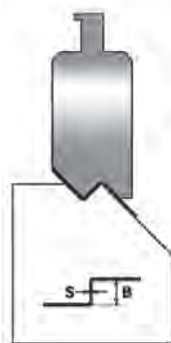

SP13

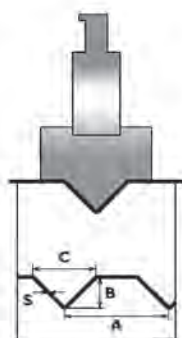

SP14

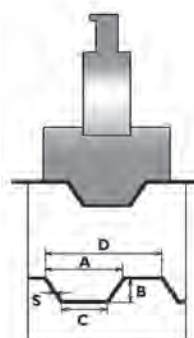

SP15/S

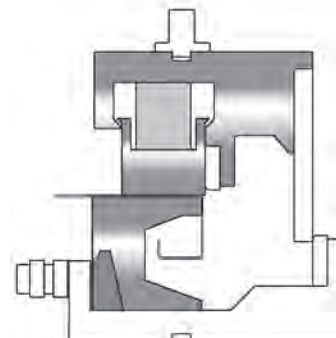

STAMPI

SPECIAL TOOLS

SP15/E

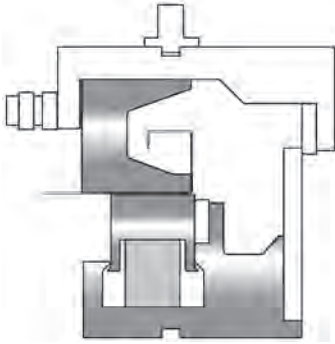

SP16

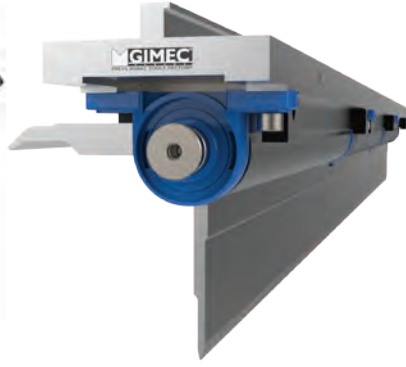
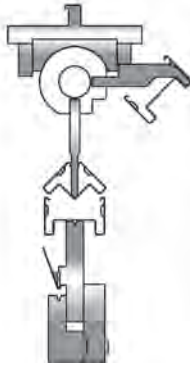

SP17

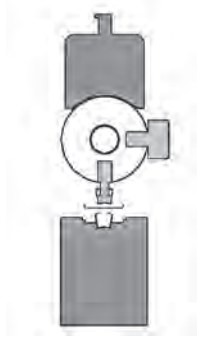

SP18

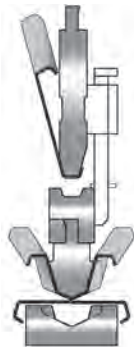

SP19

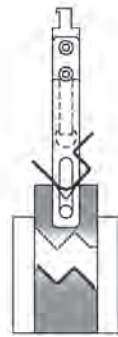

SP20



SP21



SP22



SP23



SP24



SP25



SP26

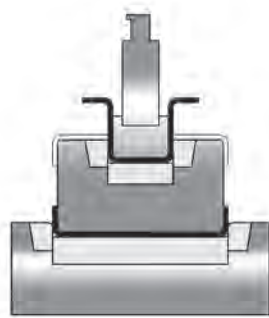

SP27



SP28

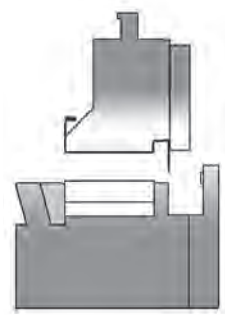

STAMPI

SPECIAL TOOLS



SP29



SP30

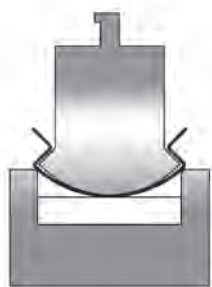

SP31

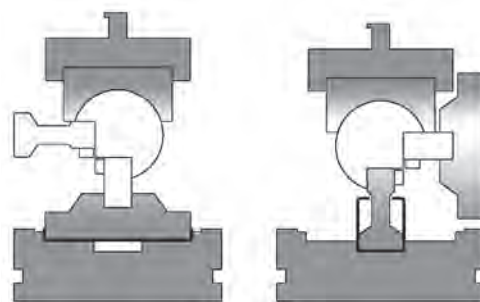

SP32

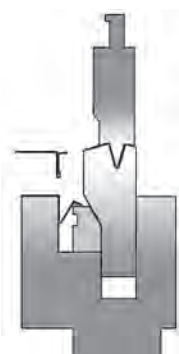

SP33

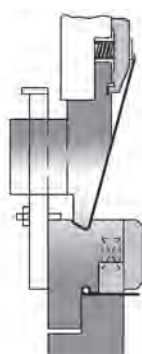

SP34

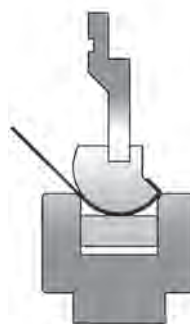

SP35



SP36

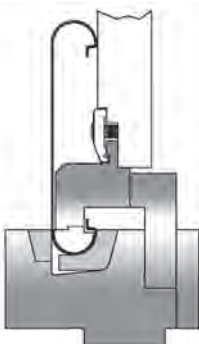

SP37

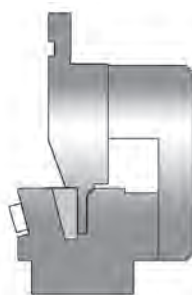

SP38

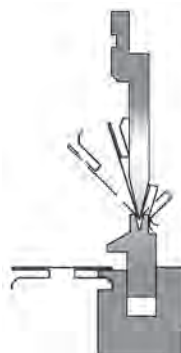

SP39

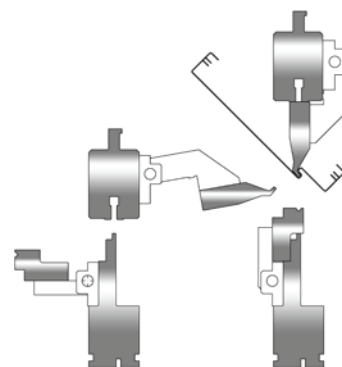

SP40

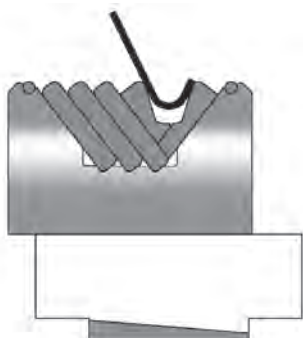

SP42

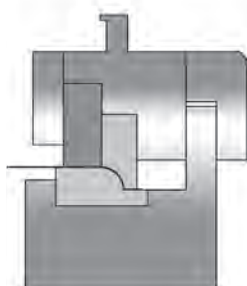

SP43

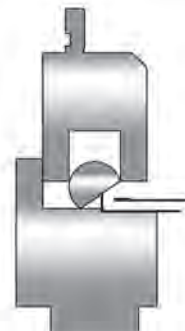

SP44

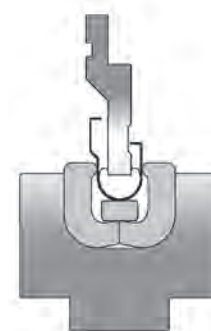

STAMPI

SPECIAL TOOLS

SP45



SP46

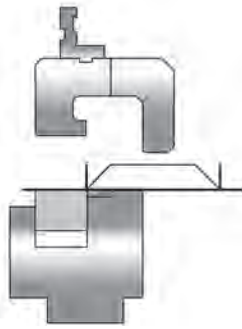

SP47

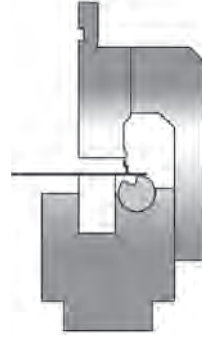

SP48



SP49

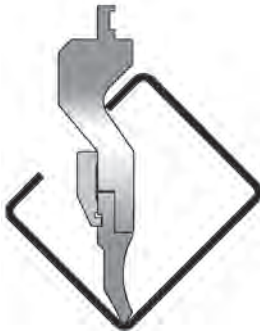

SP50

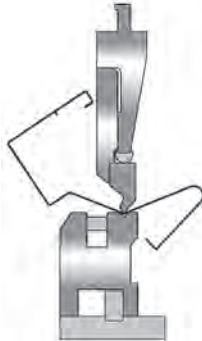

SP53

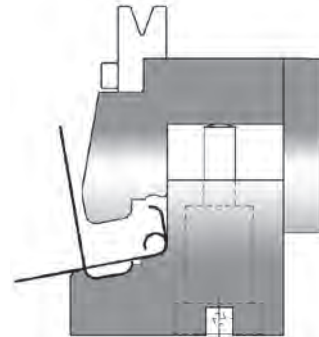

SP55

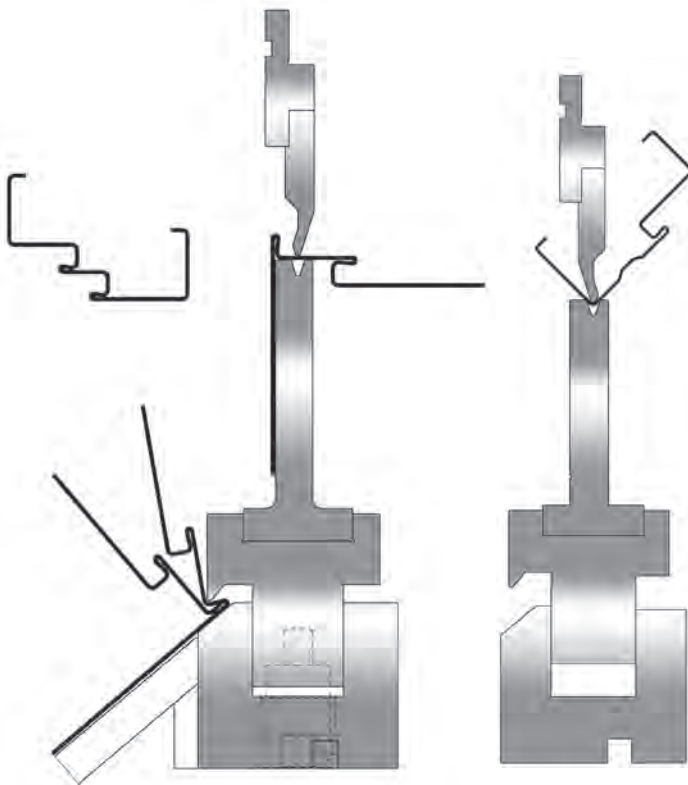

SP62

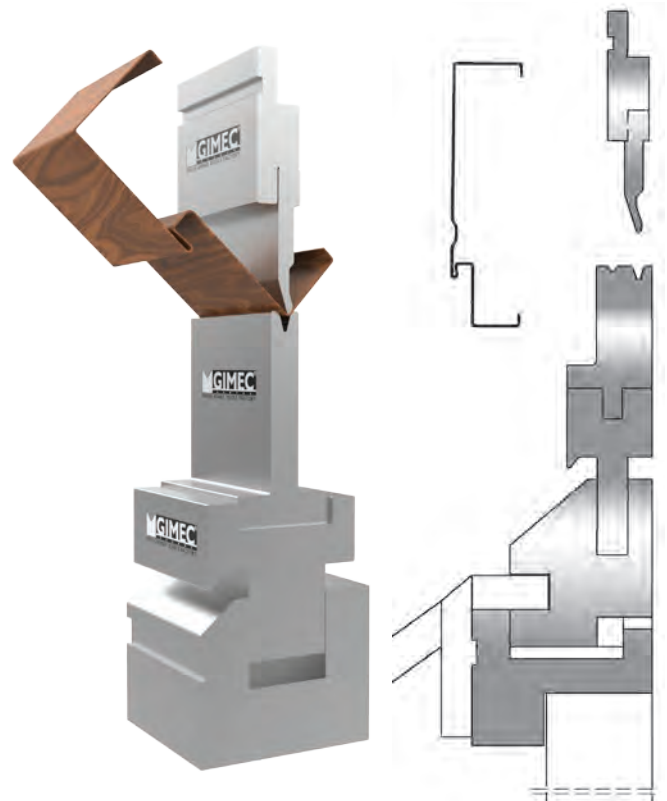

STAMPI

SPECIAL TOOLS

SP56

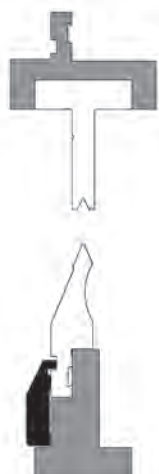

SP57

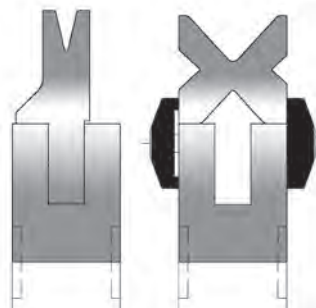

SP59

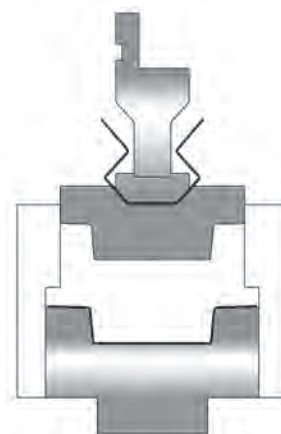

SP60

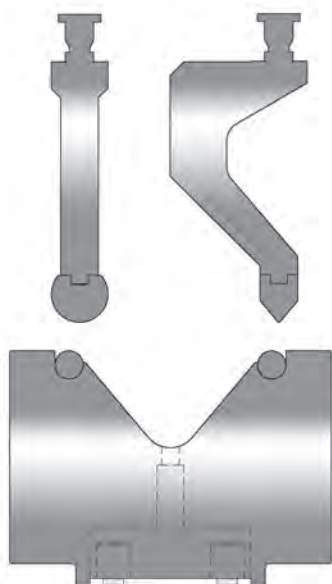

SCA-MOB-PNEU



SP63

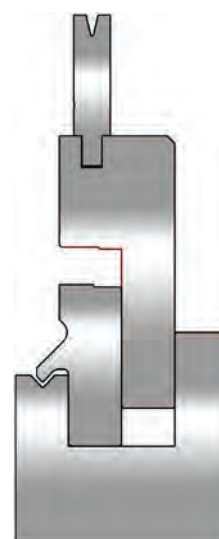

SP52

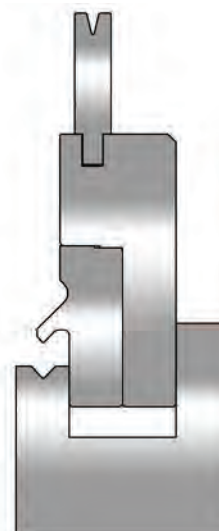
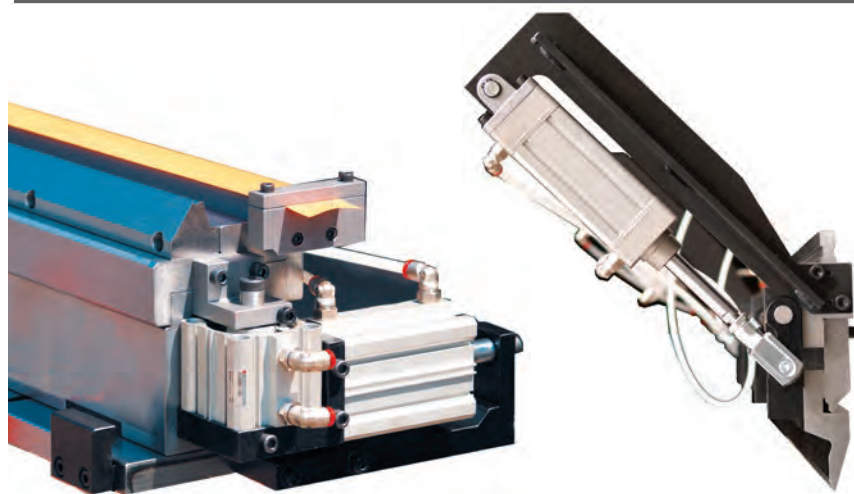

STAMPI

SPECIAL TOOLS

SP65

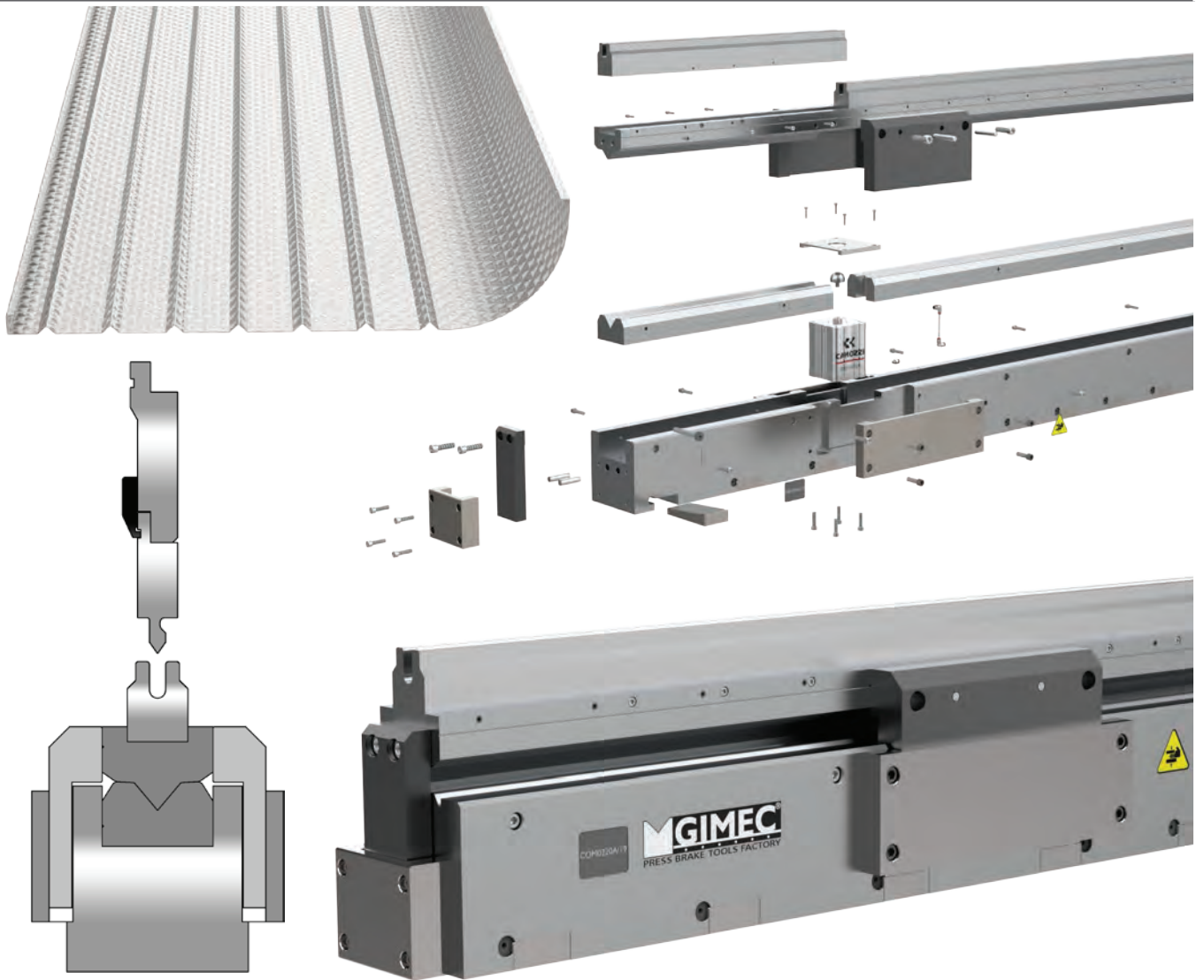

STAMPI

SPECIAL TOOLS

VIDEO VIDEOS

Stampo speciale feritoie  
Louvres special tool

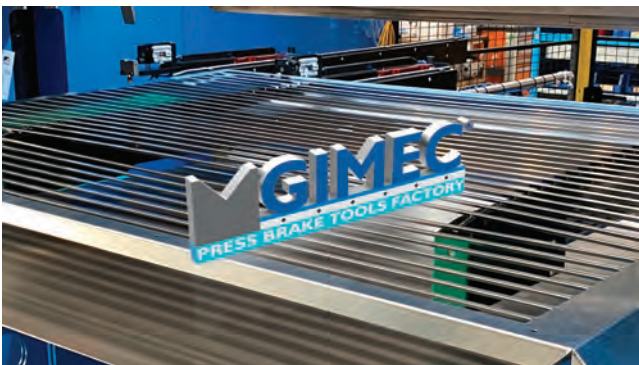

Stampo speciale door frame  
Door frame special tool



altri video disponibili sul nostro sito internet  
other videos available on our website

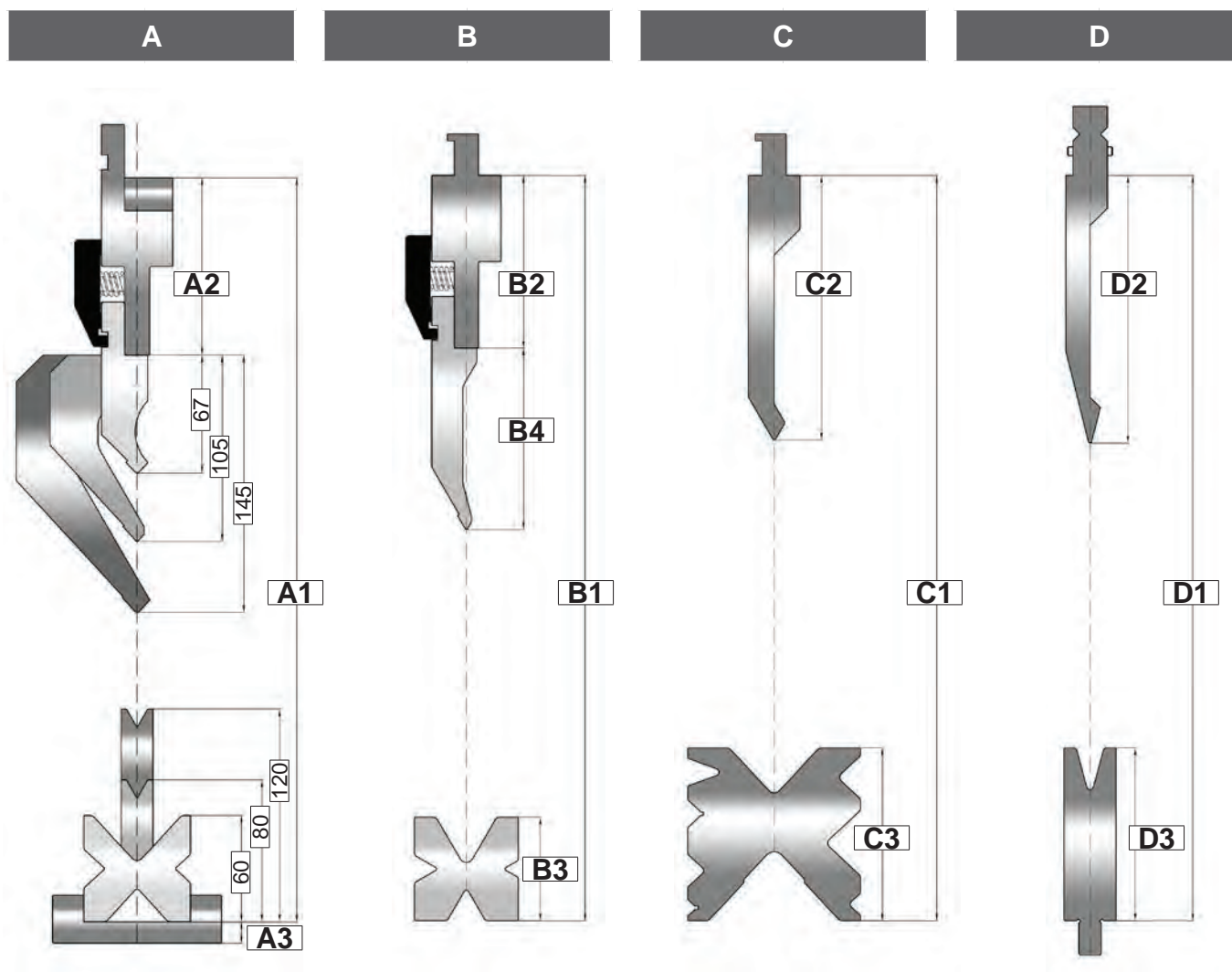

A1	mm
A2	mm
A3	mm
POTENZA POWER	kN/mt
LUNGHEZZA LEGTHS	mm
CORSA STROKE	mm
INCAVO GAP	mm

B1	mm
B2	mm
B3	mm
B4	mm
POTENZA POWER	kN/mt
LUNGHEZZA LEGTHS	mm
CORSA STROKE	mm
INCAVO GAP	mm

C1	mm
C2	mm
C3	mm
POTENZA POWER	kN/mt
LUNGHEZZA LEGTHS	mm
CORSA STROKE	mm
INCAVO GAP	mm

D1	mm
D2	mm
D3	mm
POTENZA POWER	kN/mt
LUNGHEZZA LEGTHS	mm
CORSA STROKE	mm
INCAVO GAP	mm

STAMPI

SPECIAL TOOLS

TAVOLA PORTAMATRICI CON APERTURA PNEUMATICA PER SCHIACCIATURA LAMIERA  
 DIE HOLDER TABLE WITH PNEUMATIC OPENING FOR SHEET METAL FLATTENING

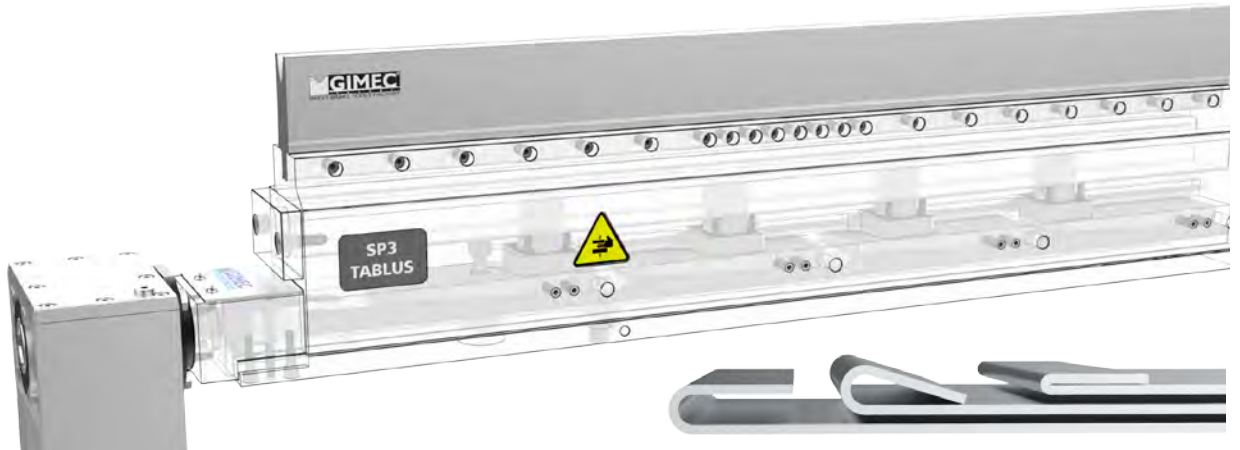

FLATTENING



L'impiego della tavola portamatrici modello SP3 permette di eseguire la schiacciatura della lamiera in modo rapido, senza dover attrezzare la pressa con gli utensili piegaschiaccia standard.

E' possibile utilizzare matrici monocava intere o frazionate, con cave, altezze e gradi differenti, in base alle caratteristiche della lamiera. Questo permette di piegare profili con eventuali contropieghe posteriori e/o laterali.

L'apertura del piano di schiacciatura viene gestita da una funzione del CNC ed avviene attraverso cilindri pneumatici speciali a singolo effetto.

Il tempo ciclo di piegatura viene ridotto notevolmente, perché, nella fase di piega, la velocità di discesa della pressa non viene rallentata, come invece accade per gli utensili piegaschiaccia con sollevamento a molle. La tavola viene fornita con sensori di posizione (aperta/chiusa).

E' possibile integrare un sistema di centinatura manuale o automatico nella parte inferiore.

Le parti di scorrimento ed i piani di schiacciatura della tavola sono temprati per evitarne l'usura.

Viene montata su presse di nuova costruzione, ma anche per retrofitting su presse già esistenti.

The use of the model SP3 die holder table allows you to perform the sheet flattening quickly without equipping the press with traditional standard tools.

It is possible to use solid or sectioned mono V dies with different slots, heights, and degrees, based on the characteristics of the sheet. This process allows bending the profiles with possible reverse bending rear or in the side.

The flattening plane's opening is managed by a CNC function and takes place through special single-acting pneumatic cylinders. The bending cycle time is considerably reduced because, in the bending phase, the descent speed of the press does not slow down, as the case with flattening tools with springs. The table is supplied with position sensors (open/closed).

It is possible to integrate a manual or automatic crowning systems in the lower part.

The sliding parts and the flattening surfaces of the table are hardened to avoid wear.

It is installed on new presses, and also for the retrofitting of existing presses.

LUNGHEZZE - LENGTHS 2010 - 3060 - 4080 - 5100 mm - oltre/beyond

MEC 60

PNE 60

MEC 13

IDR 13

SUPERIORE  
UPPER



matrici base 60 mm  
bloccaggio meccanico  
lower tools 60 mm  
mechanical clamping

matrici base 60 mm  
bloccaggio pneumatico  
lower tools 60 mm  
pneumatic clamping

matrici base 13 mm  
bloccaggio meccanico  
lower tools 13 mm  
mechanical clamping

matrici base 13 mm  
bloccaggio idraulico  
lower tools 13 mm  
hydraulic clamping

BASE 60

BASE 13



base inferiore con attacco 60 mm  
lower clamping base 60 mm

base inferiore con attacco 13 mm  
lower clamping base 13 mm

BASE STANDARD

BASE CUNEI



base standard da fissare al banco della pressa  
standard base to fix on the lower beam

base da fissare al banco con cunei di centinatura manuali  
base to fix on lower beam with manual wedges

BASE TABLUS



base con sistema automatico di centinatura TABLUS integrato  
base with integrated automatic crowning system TABLUS



CILINDRI SPECIALI  
SPECIAL CYLINDERS

INFERIORE  
LOWER

FLATTENING

**ATTREZZATURA PER PIEGATURA PROFILI DOOR FRAME  
EQUIPMENT FOR BENDING DOOR FRAME PROFILES**

**DOOR FRAME**



La piegatura di profili DOOR FRAME richiede attrezzature speciali con le quali è possibile completare l'intero ciclo di piegatura senza sostituire gli utensili.

L'attrezzatura è composta da una tavola portamatrici con cui è possibile eseguire la schiacciatura e dai relativi utensili (superiore e inferiore). Vengono inoltre forniti supporti frontali per l'appoggio della lamiera nella fase di schiacciatura.

Quando nei profili sono presenti delle lavorazioni nelle vicinanze della linea di piega (asole o tagli), si rende necessario utilizzare una matrice con doppia cava. In questo caso viene realizzato un sistema pneumatico di spostamento.

Le caratteristiche degli utensili vengono definite in base alle dimensioni dei profili.

The bending of DOOR FRAME profiles requires special equipment to complete the entire bending cycle without replacing the tools.

The equipment is made up of a tool holder table with which it is possible to perform the flattening and with the related tools (top and bottom).

Front arms are also provided for the support of the sheet metal during the flattening phase.

When there are processes in the profiles near to the bending line (slots or cuts), it is necessary to use a die with double V. In this case a pneumatic displacement system is realized.

The characteristics of the tools are defined according to the dimensions of the profiles.

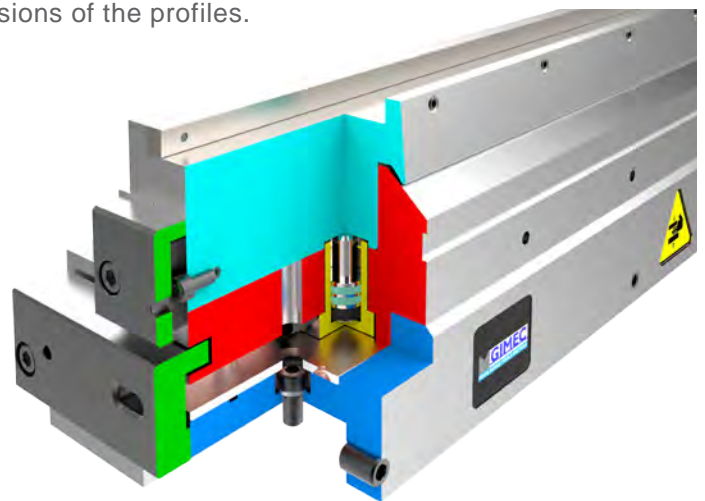

**LUNGHEZZE - LENGTHS 2550 - 3050 - 4175 mm**



## ATTREZZATURA PER PRESSE DA LATTONIERE EQUIPMENT FOR TINSMITH PRESS BRAKES



Le lavorazioni di LATTONERIA richiedono attrezzature con lunghezze superiori ai 6 metri, con sagome contenute per permettere di piegare profili tipici di questo settore.

Per maggiore flessibilità nelle varie lavorazioni, a differenza degli utensili tradizionali da lattoneria, abbiamo previsto la possibilità di effettuare il cambio della matrice in base allo spessore da piegare.

The TINSMITH workings require an equipment with lengths over than 6 meters, with small shapes to allow bending profiles typical of this field.

For greater flexibility in the various processes, unlike the traditional tools from tinning, we have provided the possibility to change the die according to the thickness that must be bent.

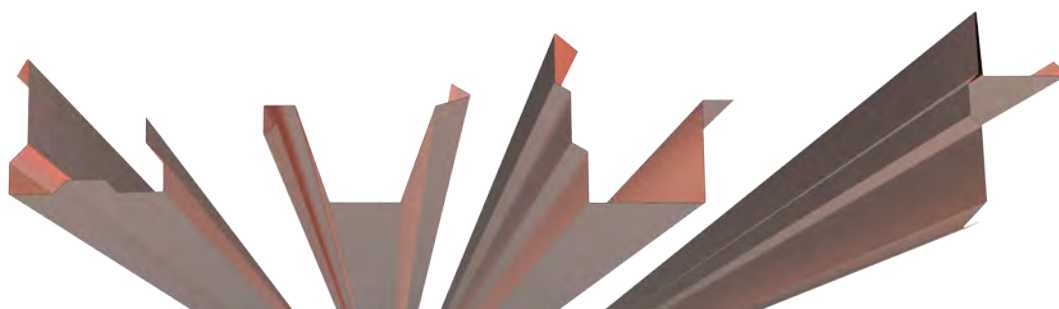
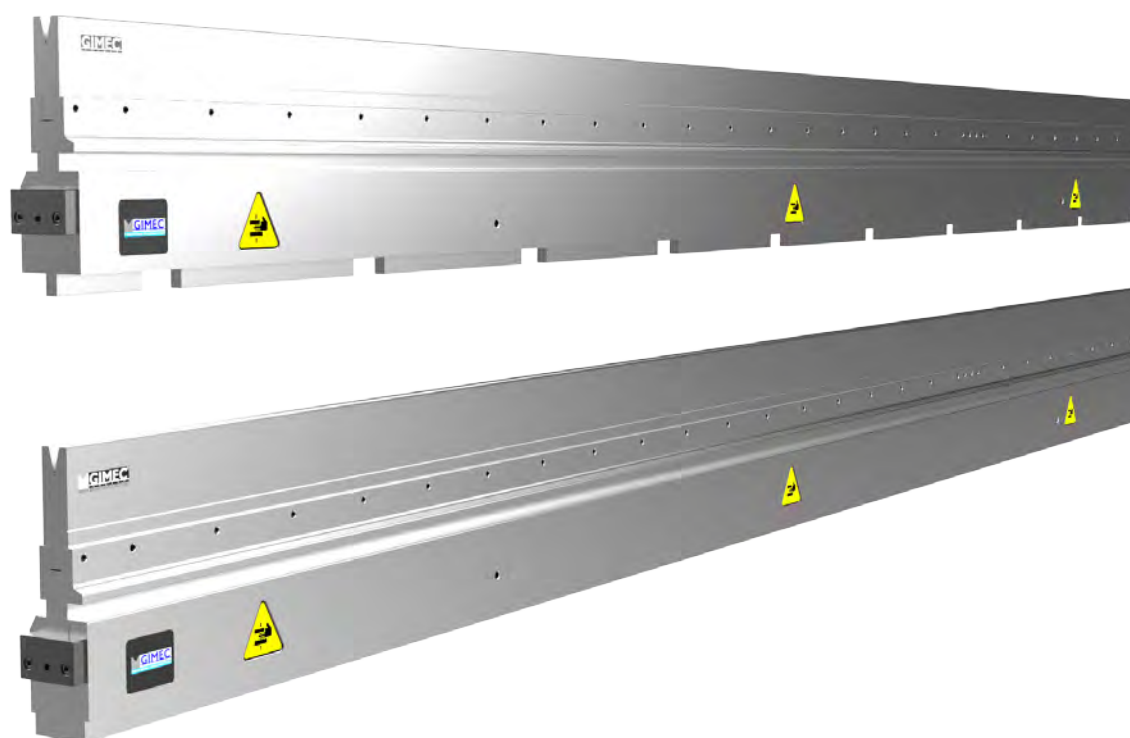

LUNGHEZZE - LENGTHS 6500 - 8550 - 10050 mm

**SISTEMA AUTOMATICO DI CENTINATURA - AUTOMATIC CROWNING SYSTEM**

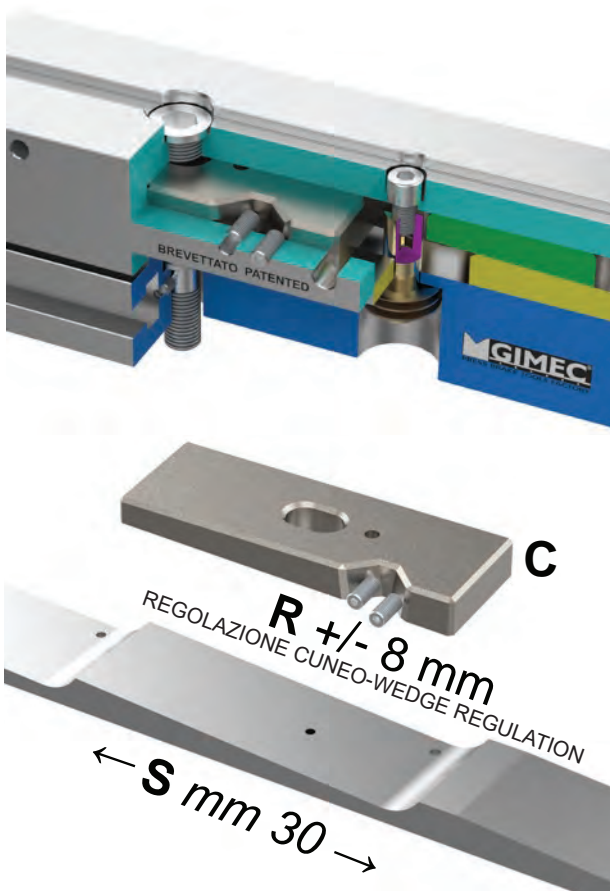

Con l'utilizzo di questo sistema è possibile compensare meccanicamente la flessione che si verifica sulle presse piegatrici durante la fase di piegatura e che determina angoli di piega irregolari. La flessione varia in funzione della lunghezza di piegatura ed in base al rapporto tra la larghezza della cava ed il tipo e spessore della lamiera.

Il sistema TABLUS (**brevettato**) è composto da una barra speciale (**S**) che scorre in contrapposizione a dei cunei (**C**). Ogni cuneo, se necessario, può essere calibrato singolarmente (**R**). La barra è azionabile manualmente (**sistema TCM-TSM**) oppure attraverso un motoriduttore controllato dal CNC della pressa piegatrice (**sistema TCMR-TSMR**). La regolazione della TABLUS viene effettuata in modo rapido e preciso prima della fase di piegatura. Ogni singola TABLUS è prodotta in base alle caratteristiche della pressa piegatrice su cui verrà utilizzata, in modo da ottimizzare il suo funzionamento. Questo avviene attraverso l'utilizzo di uno speciale software, denominato **DATA TABLUS**, che calcola le flessioni della pressa piegatrice e fornisce indicazioni su come realizzare il sistema di centinatura. Si ottiene quindi un sistema in grado di garantire una regolazione centesimale ed accurata.

Esistono più versioni di TABLUS che si differenziano in base al tipo di matrici utilizzate. Le versioni TCM-TCMR vengono fornite complete di staffe per il bloccaggio manuale delle matrici. Su richiesta può essere fornito un sistema pneumatico per il bloccaggio rapido. TABLUS viene fornita pronta per il fissaggio e l'allineamento alla pressa piegatrice.

**TABLUS**

**BREVETTATO  
PATENTED**

DATA TABLUS				esempio - example			
<b>P</b>	forza pressa	kN	<b>1200</b>	<b>L</b>	* lunghezza pressa	mm	<b>3100</b>
PESTONE				TRAVERSA INFERIORE			
LIP	distanza appoggi	mm	2650	LIT	distanza appoggi	mm	2650
LCP	lunghezza centrale	mm	2260	LCT	** lunghezza centrale	mm	2600
HP	altezza centrale	mm	1235	HT	altezza centrale	mm	845
HEP	altezza esterna	mm	495	HET	** altezza esterna	mm	435
SP	spessore pestone	mm	50	ST	spessore traversa	mm	100
				LIPm	LIP<LIPm=cunei negativi limite cunei negativi	mm	2430

\* lunghezza L sempre pari a multiplo di 200+100  
\*\* per traversa senza rientranze LCT=L e HET=HT

RINFORZO SU TRAVERSA INFERIORE			
STINF	mm		120
HTINF	mm		250

cuneo	distanze	STRISCIA S max compensazione con regolazione 30 mm	CUNEO C max compensazione con regolazione 8 mm
1	150	0,30 mm	0,08 mm
2	350	0,62 mm	0,17 mm
3	550	0,88 mm	0,24 mm
4	750	1,07 mm	0,28 mm
5	950	1,18 mm	0,32 mm
6	1150	1,27 mm	0,34 mm
7	1350	1,32 mm	0,35 mm
8	1550	1,34 mm	0,36 mm
9	1750	1,32 mm	0,35 mm
10	1950	1,27 mm	0,34 mm
11	2150	1,18 mm	0,32 mm
12	2350	1,07 mm	0,28 mm
13	2550	0,88 mm	0,24 mm
14	2750	0,62 mm	0,17 mm
15	2950	0,30 mm	0,08 mm

This system provides mechanical compensation of deflections appearing during the bending process. Deflection changes depending on bending length, die slot width, type of material and its thickness. TABLUS system (**patented**) is composed by a special rod (**S**) which is placed between opposite wedges (**C**). Every wedge can be calibrated if necessary (**R**). The rod is driven manually (**TCM-TSM system**) or by a motoreducer controlled by CNC (**TCMR - TSMR system**). The adjustment of TABLUS system is a fast and accurate procedure to execute before bending. Every TABLUS system is produced on the base of the press brake characteristics to optimize its functioning. That is provided by the use of special software **DATA TABLUS**, which calculates press brake deflections and provides crowning system throughout control commands. This system grants a very high accuracy. There are more versions of TABLUS system depending on the type of the dies used. TCM and TCMR versions are supplied with manual die clampings. On request we supply pneumatic system for fast clamping. We provide TABLUS ready for fixing and leveling on the press brake.

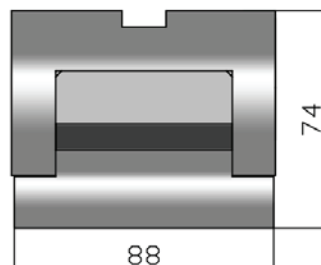
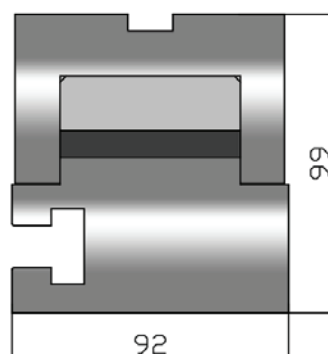
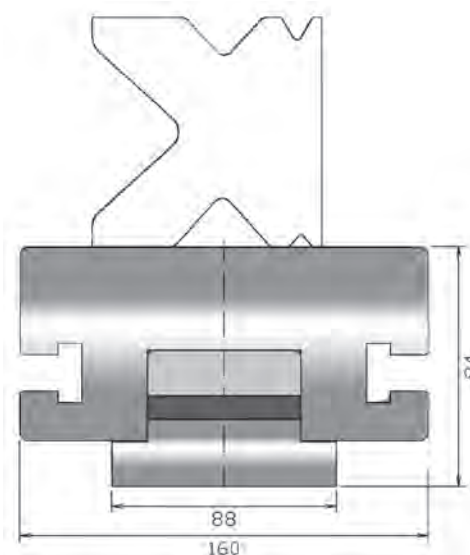
**TABLUS tipo/type TC***L mm 3100-4100-5100-6100***TABLUS tipo/type TC+T***L mm 3100-4100-5100-6100***TABLUS tipo/type T160***L mm 3100-4100-5100-6100*

TABLUS

BREVETTATO  
PATENTED

**KIT BLOCCAGGIO UTENSILI - TOOLS CLAMPING KIT**

utensili inferiori  
lower tools **SERIE 60**

**Kit 60/90 mm**

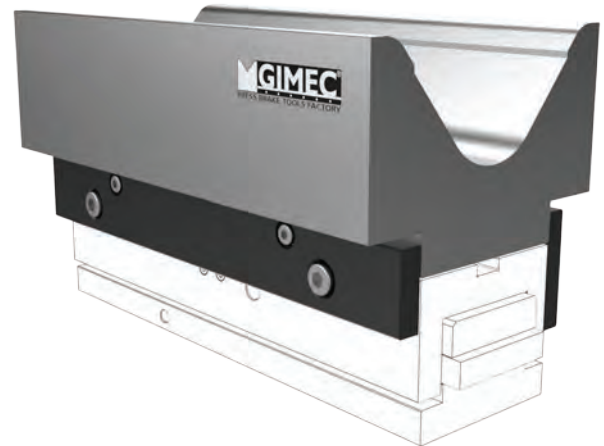

utensili inferiori  
lower tools **SERIE 13** **Kit 13,0 mm**

utensili inferiori  
lower tools **SERIE 12,7** **Kit 12,7 mm**



**MANUALE - MANUAL**

**MOTORIZZATA-MOTORIZED**



**TABLUS**  
**BREVETTATO**  
**PATENTED**

## SISTEMA DI CENTINATURA INTEGRATO - INTEGRATED CROWNING SYSTEM

Il sistema di centinatura TABLUS viene fornito anche per essere integrato nella traversa inferiore della pressa piegatrice.

La tavola portamatrici deve avere le caratteristiche minime sotto indicate. Possiamo fornire la tavola oppure comunicare al cliente le specifiche tecniche di lavorazione sia della tavola che della traversa per l'alloggiamento del sistema di centinatura.

Crowning system TABLUS can be supplied also to be integrated inside press brake lower beam.

Die holder table must have the minimum characteristics mentioned below.

We can supply it or we can give to the customer the processing specifications both for the table and the lower beam for the housing of the crowning system.

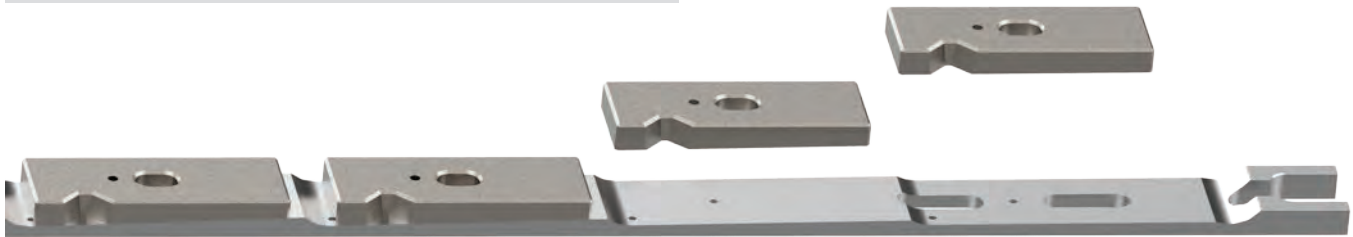

### TSM-TSMR 60

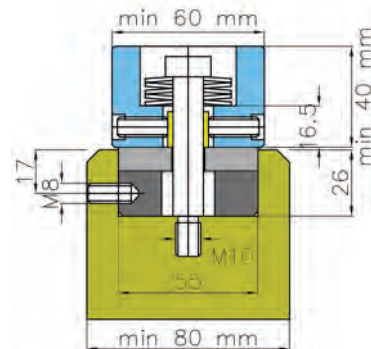
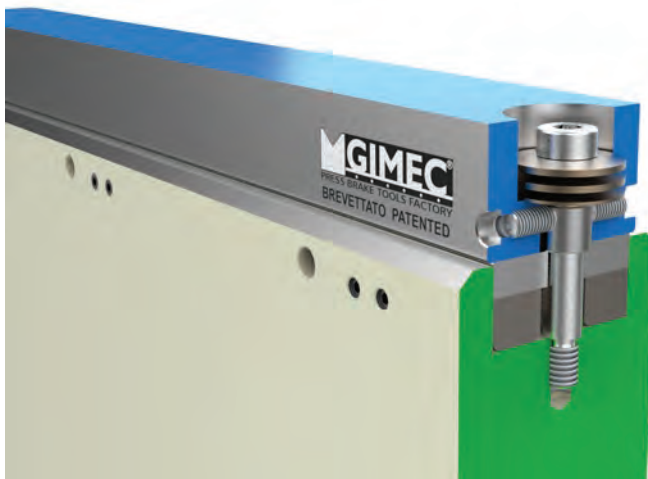

### TSM-TSMR 90

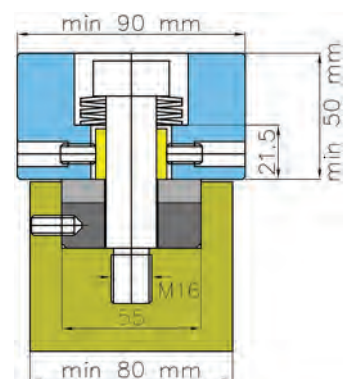

TABLUS

BREVETTATO  
PATENTED

**PL3 h96 + ST2**

*L mm 150 - max 200 kN*

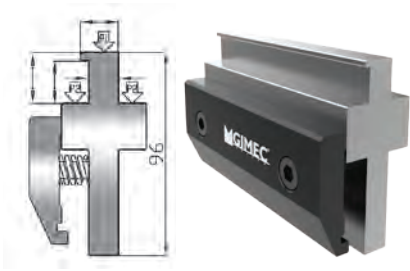

**PL3 h126 + ST2**

*L mm 150 - max 200 kN*

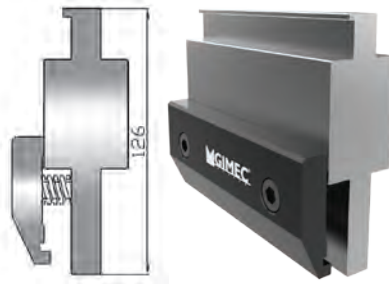

**PL3 h156 + ST2**

*L mm 150 - max 200 kN*

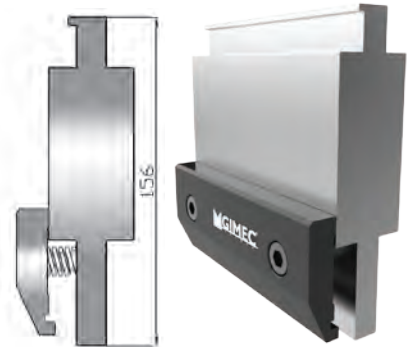

**PL5 h100 + ST2**

*L mm 150 - max 200 kN*

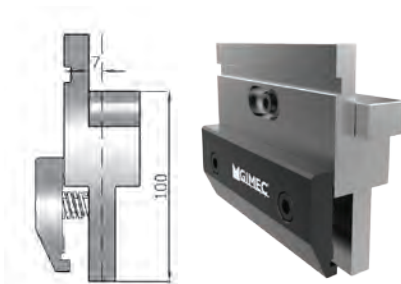

**PL5 h120 + ST2**

*L mm 150 - max 200 kN*

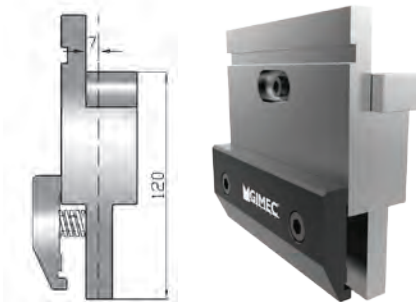

**PL5 h150 + ST2**

*L mm 150 - max 200 kN*



**PL7 h120 + ST2**

*L mm 150 - max 200 kN*

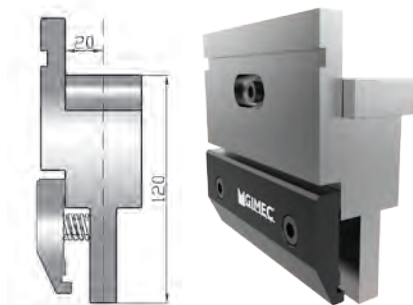

**PL8 h100 + ST2**

*L mm 150 - max 200 kN*

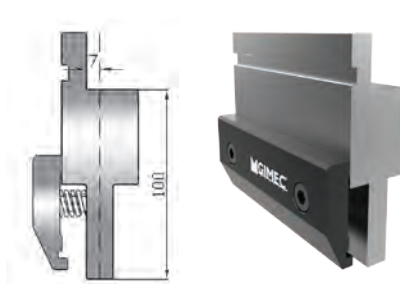

**PL14 h60 + ST2 h mm 53**

*L mm 150 - max 200 kN*

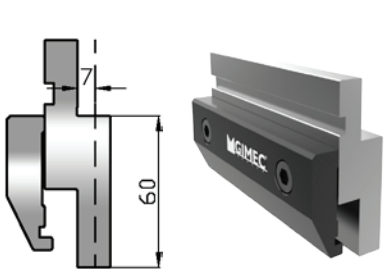

**ST1**

*L mm 150*



**ST2**

*L mm 150*

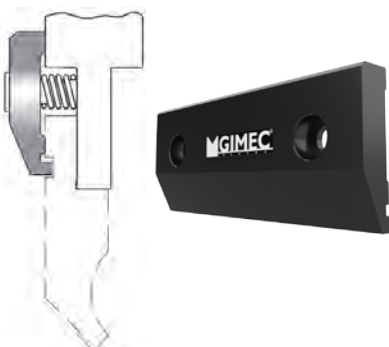

**ST2 h mm 53**

*L mm 150*

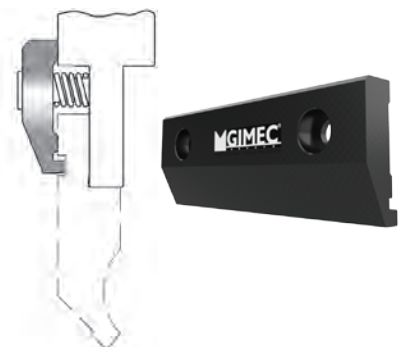

**ST2/L**

L mm 150



**ST2/X**

L mm 150



possono essere fornite con inserto in ADIPRENE /G  
can be supplied with ADIPRENE /G insert



**KIT/ST2 h 60 mm**

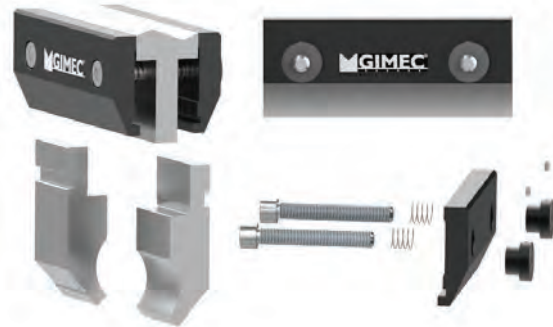

**PL4**

Trumpf-Wila ▶ traditional

L mm 150 - max 400 kN

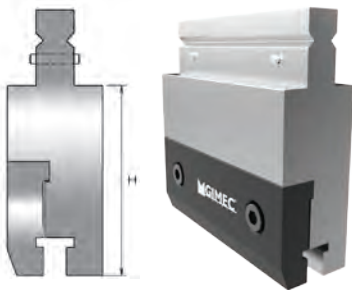

**PL6**

Trumpf-Wila ▶ Trumpf-Wila

L mm 150 - max 400 kN

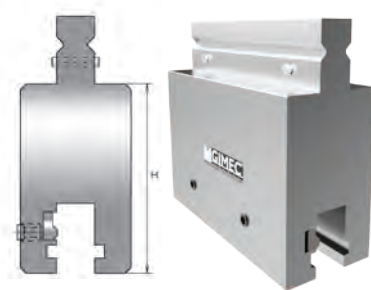

**PL9 + ST2**

Trumpf-Wila ▶ Amada

L mm 150 - max 200 kN

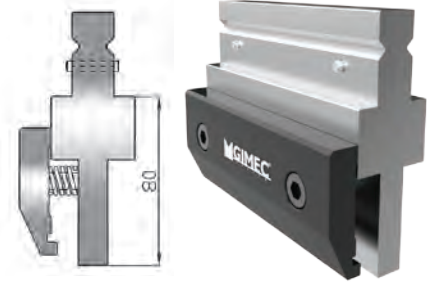

**PL10 + ST2**

COLGAR ▶ Amada

L mm 150 - max 200 kN

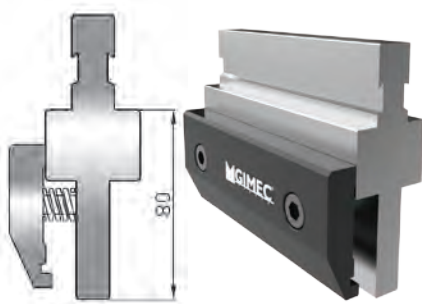

**PL11 + ST2**

Beyeler RFA ▶ Amada

L mm 150 - max 200 kN

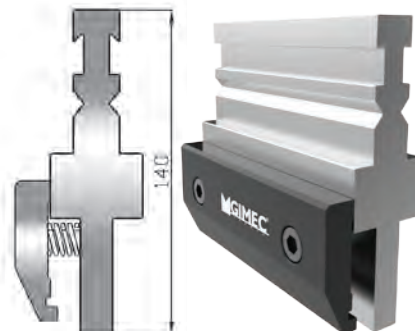

**PL12 + ST2**

Beyeler S ▶ Amada

L mm 150 - max 200 kN



**PL13 + ST2**

LVD ▶ Amada

L mm 150 - max 200 kN

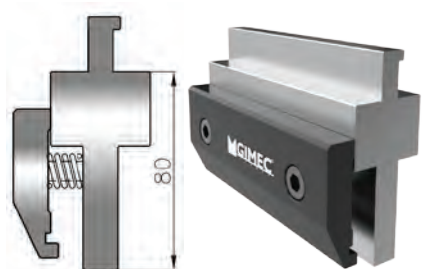

**PL16**

Amada ▶ Trumpf-Wila

L mm 150 - max 400 kN

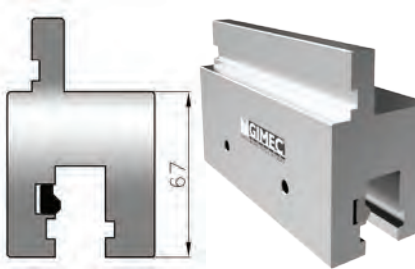

**PL17**

Amada ▶ Trumpf-Wila

L mm 150 - max 400 kN



**PL18**

*L mm 200 - max 180 kN*

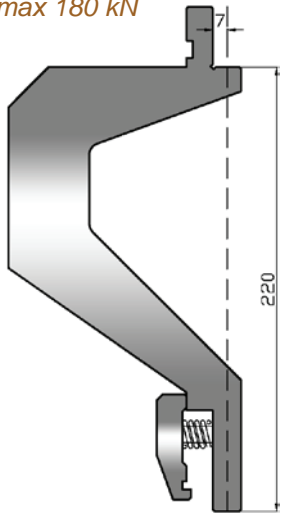

**PM6**

*L mm 2100-2600-3100-4200*

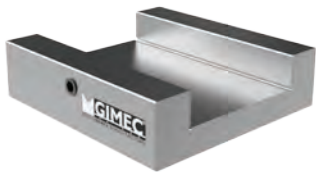
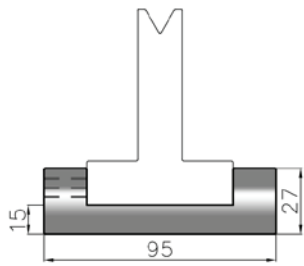

**PM6 SHORT mm 60**

*L mm 520-1050*

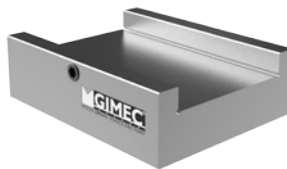
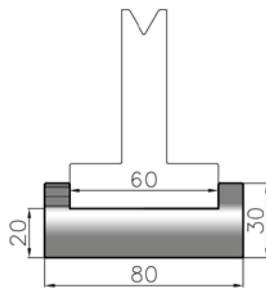

**PM6 SHORT mm 60/90**

*L mm 520-1050*

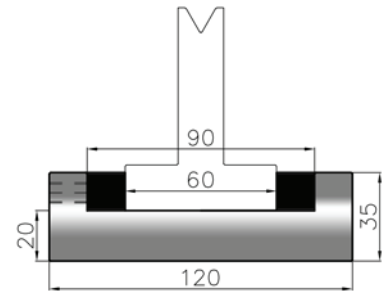

**PM5**

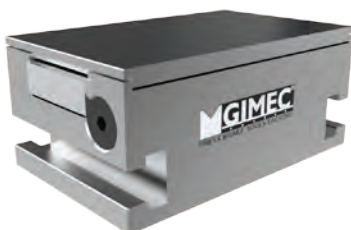

**PM7**

*L mm 2100-2600-3100-4200*

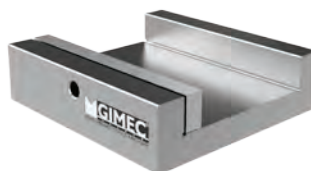
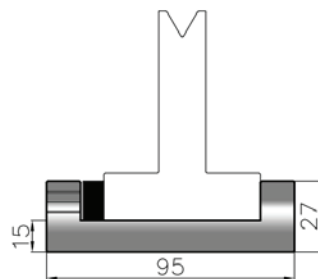

**PM8**

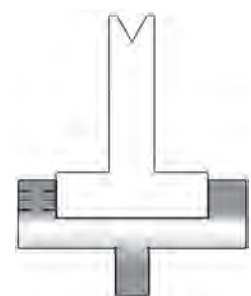



**PM9 / T**

L mm 835 - 415 Amada ▶ Trumpf-Wila

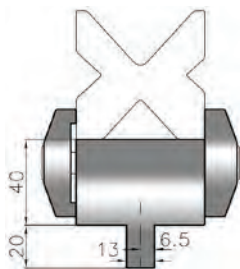

**PM9 / L**

L mm 835 - 415 Amada ▶ LVD

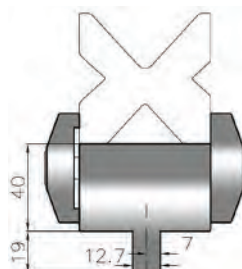

**PM9 / 60**

L mm 835 - 415

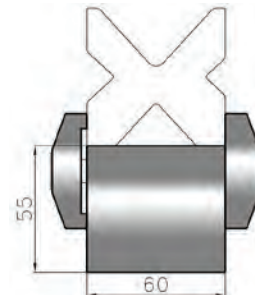

**PM10 - h 30 - h 60 mm**

L mm 500-1000

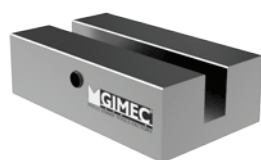
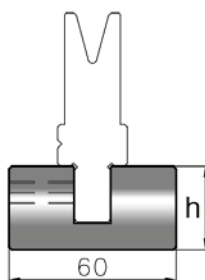

**PM11**

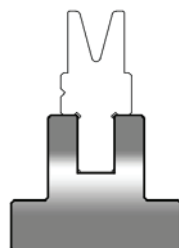

**PM12**

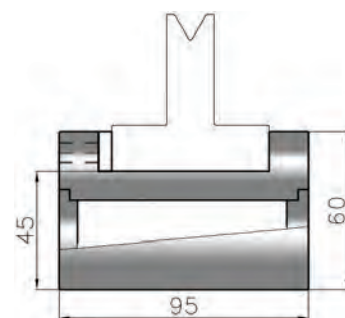

**PM13**

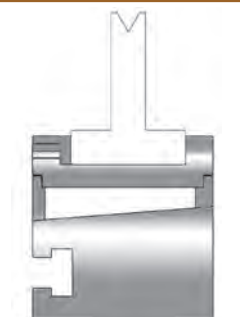

**PM14**

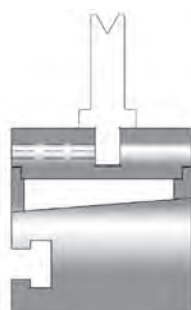

**PM15**

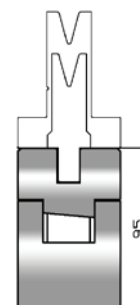

PORTA UT

## LAME RETTILINEE PER CESCOIA - RECTILINEAR SHEAR BLADES



LAME

Gimec vanta un'esperienza pluriennale nella costruzione di lame rettilinee per il taglio di lamiere. Per la loro costruzione vengono impiegati acciai di alta qualità per permettere il taglio di lamiere ad alta resistenza, quali lamiere in acciaio inox, lamiere al manganese e al silicio. Eseguiamo il trattamento termico con impianti tecnologicamente avanzati, gestiti da personale altamente qualificato. La rettifica delle superfici avviene mediante l'utilizzo di rettifiche tangenziali, per garantire la massima precisione e per evitare la formazione di micro rotture che potrebbero compromettere la durata delle lame. Al termine delle lavorazioni di rettifica, le lame vengono accuratamente smagnetizzate. Siamo inoltre attrezzati per eseguire la loro RIAFFILATURA in tempi brevissimi.



Gimec has many years of experience in the production of rectilinear blades for sheet metal cutting.

For their manufacture are used high quality of steels which allow the cutting of high strength sheet metal such as stainless steel sheets, manganese and silicon sheets.

We perform the heat treatment with technologically advanced systems, managed by qualified employees team.

The surface grinding is performed by using tangential grinding to guarantee the maximum precision and to avoid micro-cracks creations that could compromise the duration of the blades.

At the end of the grinding operations the blades are carefully demagnetized.

We are also equipped to perform the blades regrinding in very short time.

**LAME ACCIAIO tipo PV (polivalente)**

Questa tipologia di lame è adatta al taglio di lamiera con resistenza fino a  $750 \text{ kN/mm}^2$  (lamiera in ferro e acciaio inox). Per esigenze specifiche, siamo in grado di consigliare e fornire lame con differenti tipologie di acciaio e trattamento termico.

**STEEL BLADES type PV (multi-purpose)**

This type of blades is suitable for cutting sheets metal with resistance up to  $750 \text{ kN/mm}^2$  (sheet iron and stainless steel). For specific needs, we are able to recommend and supply blades with different types of steel and heat treatment.

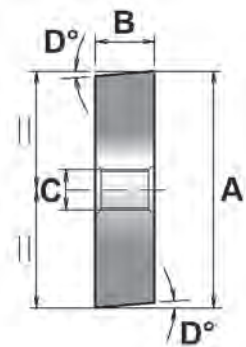
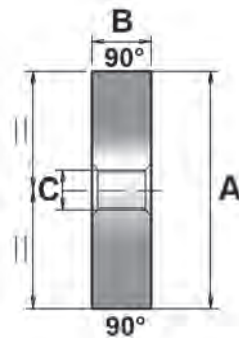
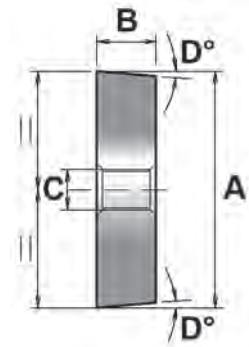
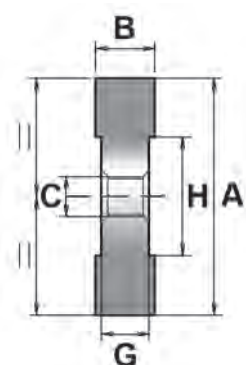
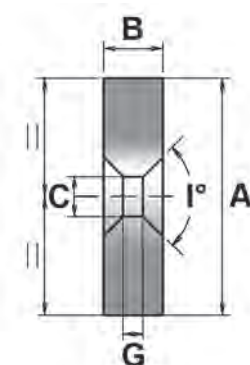
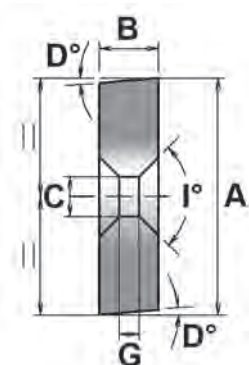
**L1****L2****L3****L4****L5****L6****SUPERIORE - UPPER****INFERIORE - LOWER**

## SQUADRA LATERALE PER CESCOIA - SQUARING ARM FOR SHEAR

SQ

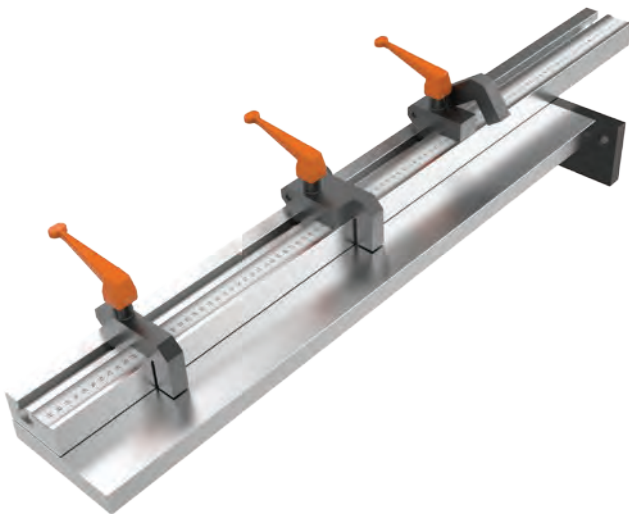

Realizziamo squadre laterali per cesoia di qualunque lunghezza che possono essere utilizzate sul lato sinistro o destro della macchina. La zona di appoggio lamiera è **temprata ad induzione** per evitare l'usura. Viene fornita completa di piastra applicazione, saltarelli fissi **SNQ**, saltarelli ribaltabili **SRQ** e sostegni regolabili in altezza. La riga millimetrata, incisa con sistema laser, è graduata per la lettura dall'alto al basso, e permette un posizionamento rapido, preciso e ripetitivo delle lamiere da tagliare.

We provide squaring arm for shears of any length which you can use on both sides of the machine. The sheet metal support area is **induction hardened** to avoid the wear. It is supplied by an application plate, fixed click **SNQ**, tipping click **SRQ** and height adjustable supports. The millimeter bar, engraved with a laser system, is graduated to reading from top to bottom. It allows a rapid, precise and repetitive placement of the sheets to be cut.

ATTREZZATURE

## GONIOMETRO PER CESCOIA - GONIOMETER FOR SHEAR

G

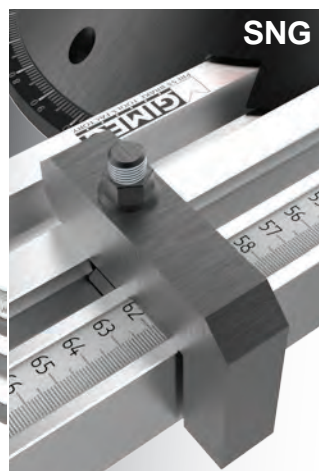

L'utilizzo di questo goniometro permette di posizionare la lamiera per tagli angolati. L'applicazione è stata prevista per cesoie con banco di lavoro "pieno". Su richiesta viene fornito per applicazioni differenti. E' disponibile in 2 versioni:

**MODELLO G1** lunghezza barra a squadrare temprata L.mm.1000, fornito con piastra applicazione, riga millimetrata, 1 saltarello fisso **SNG** e 1 saltarello ribaltabile **SRG**

**MODELLO G2** lunghezza barra a squadrare temprata L.mm.500, fornito con piastra applicazione, riga millimetrata, 1 saltarello fisso **SNG**

The use of this goniometer allows the metal sheet angled cut placements. The application has been planned for shears with a "full" workbench. On request it is supplied for various applications. The goniometer is available in 2 versions:

**G1 MODEL** hardened squared bar length mm 1000 supplied with application plate, millimeter bar, 1 fixed click **SNG** and 1 tipper click **SRG**

**G2 MODEL** hardened squared bar length mm 500 supplied with application plate, millimeter bar, 1 fixed click **SNG**

## RIFERIMENTI ANTERIORI PER CESCOIA - FRONT REFERENCES FOR SHEAR

R

Costruiamo 3 diverse tipologie di profili in acciaio, da utilizzare nella parte anteriore della cesoia, per facilitare la movimentazione e il posizionamento delle lamiera. I riferimenti vengono forniti con i seguenti accessori:

- saltarelli escludibili o ribaltabili
- saltarelli con regolazione micrometrica della battuta
- blocchetti con sfere per facilitare lo scorrimento della lamiera
- rondelle escludibili per permettere la squadratura lamiera
- riga millimetrata incisa laser, graduata per lettura verticale
- eventuali sostegni regolabili in altezza

L'applicazione varia in funzione delle caratteristiche della cesoia.

We produce 3 different types of steel profiles which are used in the front part of the shears, in order to simplify the handling and the positioning of the sheets. The references are supplied by the following accessories:

- excludable clicks or tipper clicks
- clicks with micrometric adjustment of the stop
- blocks with spheres to simplify the sliding of the sheet
- excludable washers to allow the squaring of the sheet
- millimetric rule laser engraved, graduated for vertical reading
- height adjustable supports

The application methods can change according to the shear features.



ATTREZZATURE

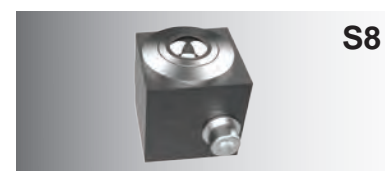
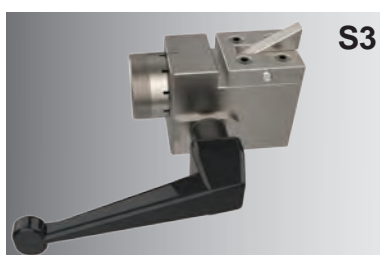
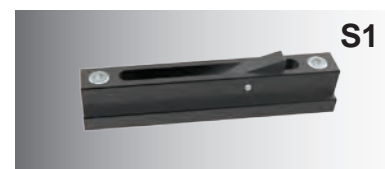

## RIFERIMENTI PER PRESSA PIEGATRICE - REFERENCES FOR PRESS BRAKE

Questi riferimenti vengono utilizzati nella parte anteriore della pressa e facilitano la movimentazione e il posizionamento delle lamiere.

I riferimenti vengono forniti con i seguenti accessori:

- saltarelli escludibili o ribaltabili **S2**
- saltarelli con regolazione micrometrica della battuta **S3**
- blocchetti con sfere per facilitare lo scorrimento lamiera **S8**
- rondelle escludibili per permettere la squadratura lamiera **S7**
- riga millimetrata incisa laser, graduata per lettura verticale
- eventuali sostegni regolabili in altezza

This references are used in the front part of the press brake, in order to simplify the handling and the positioning of the sheet metal.

The references are supplied by the following accessories:

- excludable clicks or tipper clicks **S2**
- click with micrometric adjustment of the stop **S3**
- blocks with spheres to simplify the sliding of the sheet **S8**
- excludable washers to allow the squaring of the sheet **S7**
- millimetric rule laser engraved, graduated for vertical reading
- height adjustable supports

SS



Riferimento in acciaio. E' regolabile in altezza ed è applicabile a qualsiasi tipo di pressa piegatrice  
Steel reference. The height is adjustable and it can be used on any type of press brake

S2



S3

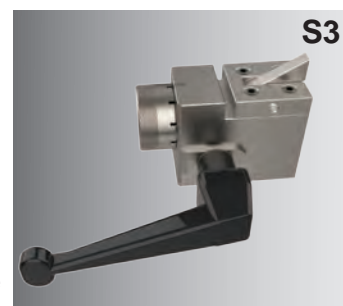

S7



S8



RR



Riferimento in lamiera. E' consigliata l'applicazione su presse piegatrici tipo AMADA/SCHIAVI (L.mm 500-1000-1500)  
Sheet reference. The use is recommended on AMADA / SCHIAVI press brakes type (L.mm 500-1000-1500)

## SQUADRA PER PRESSA PIEGATRICE - PRESS BRAKE SQUARING

## SPQ 30° ÷ 90°



Questa attrezzatura è da posizionare direttamente sull'utensile inferiore e può essere utilizzata per la piegatura in squadra (90°) di particolari di lamiera di piccole dimensioni, oppure, montando l'apposito goniometro, si ha la possibilità di regolare l'appoggio da 90° a 30°, quando il pezzo da piegare non è perpendicolare all'asse di piegatura.

This equipment needs to be placed directly on the lower tool and it allows the square bending (90°) of small sheet metal part, otherwise, setting up the dedicated goniometer be able to adjust the support from 90° to 30° when the piece to bending is not perpendicular to the bending axis.



## SPQ/G 30° ÷ 90°

Questa attrezzatura è da posizionare sull'utensile inferiore e permette la piegatura di particolari di lamiera di piccole dimensioni, con la possibilità di regolare l'appoggio da 90° a 30°, quando il pezzo ha un appoggio non perpendicolare all'asse di piegatura.

This equipment needs to be placed directly on the lower tool and it allows the bending of small sheet metal parts, with the possibility to adjust the support from 90° to 30°, when the piece to produce has a support not perpendicular to the bending axis.

## UNITA' DI PIEGATURA - BENDING UNIT

UP



Questa attrezzatura può essere utilizzata su presse idrauliche o meccaniche, per eseguire la piegatura di particolari di piccole dimensioni.

In questo modo è possibile evitare di impiegare presse piegatrici di lunghezze superiori.

E' disponibile in 2 differenti lunghezze utili di piegatura : mm. 415 - mm.835.

Per la scelta degli utensili occorre prendere visione della serie standard tipo EUROPA.

This equipment can be used on hydraulic or mechanical presses and it allows to perform the bending of small details. In this way it's not possible to use the longer length bending presses.

The bending unit is available in 2 different lengths : mm. 835 - mm. 415. For the selection of the tools you need to take a look at the EUROPE standard series.

## PELLICOLA ANTIGRAFFIO - DIE COVER FILM

## GIMEC-URET

**Non troverete in nessun altro luogo una pellicola più tenace e duratura !!!**

**Nowhere else you can find a more strong and lasting film !!!**



L'utilizzo di questo prodotto permette di eseguire la piegatura di acciaio inox, alluminio o altro, evitando graffi e segni di piegatura sul pezzo piegato, coprendo semplicemente gli utensili con la pellicola antigraffio. Durante l'utilizzo la pellicola agisce come protezione tra lo stampo ed il materiale da piegare proteggendo quest'ultimo da graffi o segni di piegatura.

La pellicola GIMEC-URET viene fornita in rotoli standard con una lunghezza di mt 30 e sezione mm 100 x 0,5.

Per ottimizzare la durata della pellicola, seguire la seguente procedura:

- regolate la pressa piegatrice fino ad ottenere l'angolo di piega desiderato
- alzate la pressa approssimativamente di mm 0,4 MOLTO IMPORTANTE !
- coprite la matrice con la pellicola (utilizzando la coppia di tenditori GIMEC-TENS)
- iniziate la piegatura

La durata della pellicola dipende da molteplici fattori quali il tipo di lamiera utilizzata, lo spessore, l'angolo di piega, la larghezza e i raggi della cava. Controllate la pellicola per eventuali segni di deterioramento e sostituirla quando è usurata.

Con l'utilizzo dei tenditori è possibile far scorrere la pellicola in modo da riposizionarla nei punti in cui non risulta usurata. Questo permette di poterla sfruttare totalmente nella sua larghezza.



**GIMEC-TENS  
0÷60 mm**



**GIMEC-TENS  
0÷112 mm**

This product allows you to bend stainless steel, aluminum and more materials avoiding scratches and bending marks just covering the tools with this anti-scratch film.

The film acts as a protection between the die radius and the material to bend, preserving it from scratches or bending marks.

The GIMEC-URET film is supplied by standard rolls of 30 meters length and cross section of 100 x 0.5 mm.

To optimize the endurance please follow the following procedures:

- adjust the bending press to obtain the desired bending angle
- raise the press approximately by mm 0.4 VERY IMPORTANT !
- cover the die with the film

(using the pair of tensioners GIMEC-TENS)

- start bending

The cover film lifetime depends on many factors such as the type of sheet metal used, thickness, angle of the bend, dimension of the V slot and radius of the die. Check the film for any signs of deterioration and replace it when it is worn.

Using the tensioners, it is possible to slide the film to reposition it in the points where it is not worn. This allows it to be fully exploited in its width.





## ARMADIO UTENSILI APERTO - OPEN TOOLS CABINET **ARM-OPEN2/835**

Idoneo per lo stoccaggio di utensili tipo **EUROPA** con lunghezza mm 835 - 415 - 805 frazionati.

L'utilizzo di questo armadio facilita l'operatore nella movimentazione degli utensili e permette una rapida visualizzazione delle tipologie disponibili.

Caratteristiche:

- 6 ripiani con traversini per alloggiare sia utensili superiori che inferiori.  
i ripiani sono regolabili in altezza  
portata singolo ripiano 190 kg (n°11 binari)
- 2 cassetti per riporre gli utensili frazionati  
portata singolo cassetto 75 kg  
altezza max utensile 130 mm
- Capienza ripiani + cassetti : max 74 utensili
- Dimensioni : cm 86 x 86 altezza cm 161,5
- Verniciato monocoloro Ral 7016 grigio antracite bucciato

It is suitable for the storage of **EUROPA** tools with a length of mm 835 - 415 - 805 sect.

The use of this cabinet helps the operator in the handling of the tools and it allows a quick display of the available tools.

Features:

- 6 shelves with crossbars to store both upper and lower tools.  
the shelves are adjustable in height  
single load capacity of 190 kg (n°11 tracks)
- 2 drawers to store tools in section  
single drawer capacity 75 kg  
max tool height 130 mm
- Capacity shelves + drawers: max 74 tools
- Size: 86 x 86 cm height 161,5 cm
- One-color painted anthracite gray peel Ral 7016

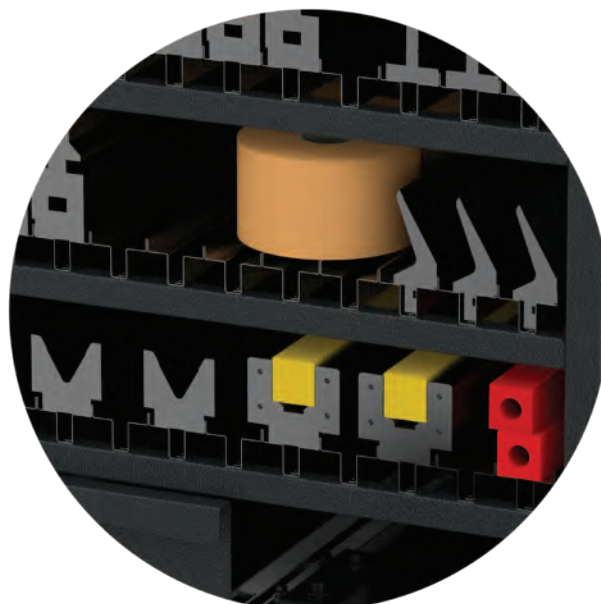

## CARRELLO PORTA UTENSILI - TOOLS TROLLEY

## ARM-WHEELS

L'utilizzo di questo carrello ha i seguenti vantaggi:

- facilità nel riporre gli utensili
- rapida visualizzazione delle tipologia di utensili a disposizione dell'operatore
- praticità negli spostamenti essendo dotato di ruote

E' disponibile in 3 versioni :

**ARM / WHEELS 1**

idoneo per stoccaggio utensili tipo **EUROPA**  
con lunghezza mm 835 - 415 - frazionati  
Capacità : 30 ripiani

**ARM / WHEELS 2**

idoneo per stoccaggio utensili tipo **TRUMPF WILA®**  
con lunghezza mm 500 - 515 - frazionati  
Capacità : 21 ripiani

**ARM / WHEELS 3**

idoneo per stoccaggio utensili tipo **BEYELER BYSTRONIC®**  
con lunghezza mm 500 - 508 - 1000 - frazionati  
Capacità : 21 ripiani

Dimensioni : cm 116 x 106 altezza cm 152  
Portata max : kg.1000

The open tools cabinet has several advantages:

- easy storage of tools
- quick display of the different types of tools available to the operator
- easy to move being equipped with wheels

It is available in 3 versions:

**ARM / WHEELS 1**

It is suitable for the storage of **EUROPA** tools  
with length mm 835 - 415 - 805 sect.  
Capacity: 30 shelves

**ARM / WHEELS 2**

It is suitable for the storage of **TRUMPF WILA®** tools  
with length mm 500 - 515 - sect.  
Capacity: 21 shelves

**ARM / WHEELS 3**

It is suitable for storage of **BEYELER BYSTRONIC®** tools  
with length mm 500 - 508 - 1000 - sect  
Capacity: 21 shelves

Dimensions : 116 x 106 cm height 152 cm  
Max capacity : 1000 kg

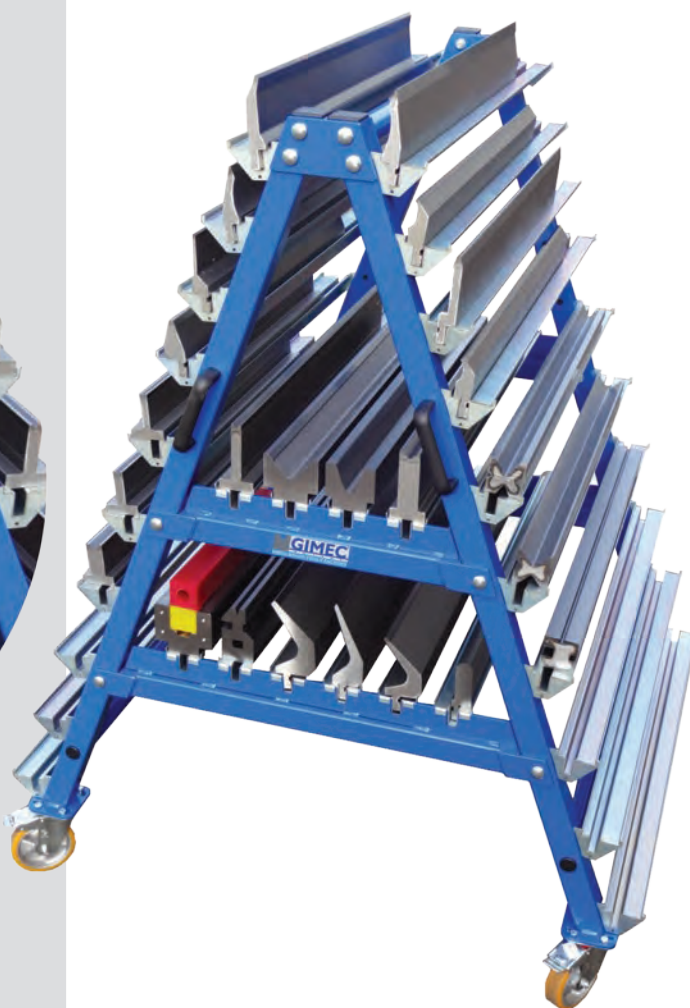
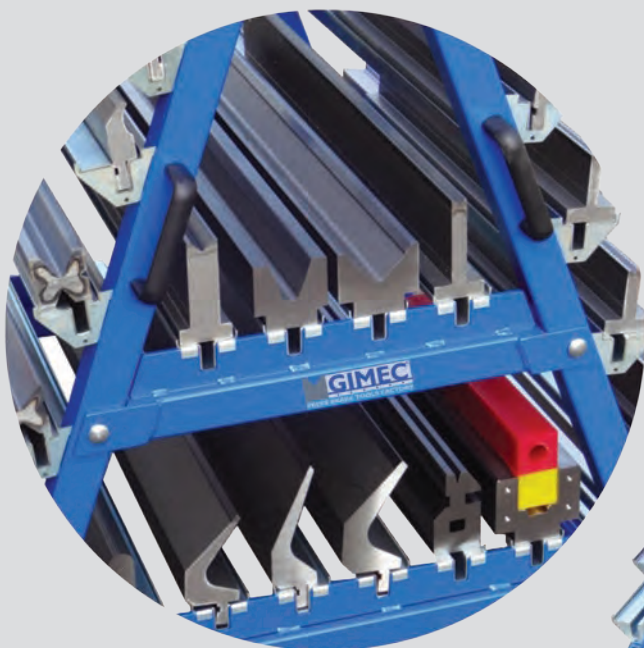

## ARMADIO PORTA UTENSILI - TOOLS CABINET

## ARM 4-5

L'utilizzo di questo armadio ha i seguenti vantaggi :

- struttura molto robusta con cassetti verticali dotati di ruote
- facilità di posizionamento degli utensili
- possibilità di posizionare i ripiani all'interno dei cassetti secondo le proprie esigenze
- l'armadio è predisposto con delle scanalature nella parte inferiore per facilitare il sollevamento e spostamento

E' disponibile in diverse versioni, con le seguenti caratteristiche standard:

**ARMADI idonei per UTENSILI tipo EUROPA**

- **ARM4/835/13** con 4 cassetti (16 supporti+4 vaschette)  
capacità: circa 20 metri di utensili - cm 85Lx105Px124H
- **ARM5/835/13** con 5 cassetti (20 supporti+5 vaschette)  
capacità: circa 25 metri di utensili - cm 104Lx105Px124H
- **ARM4/1060/13** con 4 cassetti (20 vaschette)  
capacità: circa 30 metri di utensili - cm 85Lx136Px124H
- **ARM5/1060/13** con 5 cassetti (25 vaschette)  
capacità: circa 38 metri di utensili - cm 85Lx136Px124H

**ARMADI IDONEI PER UTENSILI tipo TRUMPF WILA ® and BEYELER BYSTRONIC ®**

- **ARM4/1060/20** con 4 cassetti - cm 85Lx136Px124H
  - **ARM5/1060/20** con 5 cassetti - cm 104Lx136Px124H
- L'allestimento interno dei supporti e delle vaschette viene proposto in base agli utensili da alloggiare

By using this cabinet you will get the following benefits:

- very strong structure with vertical wheeled drawers
- easy storage of tools
- the possibility to place shelves inside the drawers according to your needs
- the cabinet is equipped with grooves in the lower part to allow you to lift and move it.

It is available in different versions, with the following standard features:

**CABINET suitable for EUROPEAN TOOLS**

- **ARM4 / 835/13** with 4 drawers (16 supports + 4 trays)  
capacity: about 20 meters of tools - cm 85Lx105Px124H
- **ARM5 / 835/13** with 5 drawers (20 supports+5 trays)  
capacity: about 25 meters of tools - cm 104Lx105Px124H
- **ARM4/1060/13** with 4 drawers (20 trays)  
capacity: about 30 meters of tools - cm 85Lx136Px124H
- **ARM5/1060/13** with 5 drawers (25 trays)  
capacity: about 38 meters of tools - cm 85Lx136Px124H

**CABINET suitable for TOOLS TRUMPF WILA ® and BEYELER BYSTRONIC ®**

- **ARM4 / 1060/20** with 4 drawers - cm 85Lx136Px124H
  - **ARM5 / 1060/20** with 5 drawers - cm 104Lx136Px124H
- The internal set-up of the supports and trays is proposed to you according to the tools to be housed.





### ACCIAI

Per la costruzione vengono impiegati acciai di primissima qualità, sottoponendoli ad accurati controlli prima e durante le varie fasi di lavorazione.

### STEEL

We use the highest quality steels, subjecting them to accurate checks before and during the various stages of processing.

<b>C45</b>	C45	W 1.1191	R 600 / 750 N/mm <sup>2</sup>
<b>42CR</b>	42CrMo4	W 1.7225	R 850/1000 N/mm <sup>2</sup>
<b>2311</b>	40CrMnMo7	W 1.2311	R 950/1100 N/mm <sup>2</sup>
<b>2312</b>	40CrMnMoS8,6	W 1.2312	R 950/1050 N/mm <sup>2</sup>
<b>PV</b>	X155CrVMo12-1	W 1.2379	

### TRATTAMENTI TERMICI

Tutti i trattamenti termici sono eseguiti con impianti tecnologicamente avanzati, gestiti da personale altamente qualificato :

- tempra laser
- tempra ad alta frequenza
- tempra a cuore

### HEAT TREATMENTS

All heat treatments are performed with technologically advanced systems and managed by highly qualified employees:

- laser hardening
- high frequency service
- fully hardening



### LAVORAZIONI MECCANICHE

Siamo attrezzati con moderni macchinari che ci permettono di eseguire, con la massima precisione, le principali lavorazioni di fresatura CNC, rettifica tangenziale CNC e ogni altra lavorazione complementare.

### MECHANICAL WORKING

We are equipped with modern processing systems, which allow us to provide the main CNC milling operations, CNC tangential grinding and any other complementary operations with the highest precision.



### **PROGETTAZIONE & OFFERTE**

I nostri uffici tecnico-commerciali sono in grado di fornire, in tempi brevi, una soluzione tecnica ai vostri problemi di piegatura.

Ogni offerta viene accompagnata da disegni tecnici esemplificativi affinché possiate comprendere al meglio quanto proposto.

### **TECHNICAL DESIGN & OFFERS**

Our technical and commercial offices are able to provide technical solutions to solve your bending problems very quickly.

In each offer will be included example technical drawings in order to let you better understand what we propose you.

### **REVISIONE STAMPI**

Siamo attrezzati per eseguire la revisione di stampi per presse piegatrici con consegna rapidissima per evitare fermi macchina.

### **PRESS BRAKE TOOLS RECONDITIONING**

We are equipped to perform the reconditioning for press brakes tools with a very fast delivery to avoid machine downtime.



### **RIAFFILATURA LAME**

Eseguiamo in tempi rapidi la riaffilatura delle lame per cesoia. La riaffilatura viene eseguita con rettifiche tangenziali per mantenere inalterate le caratteristiche delle lame. Tutte le lame dopo la riaffilatura vengono smagnetizzate.

### **SHEAR BLADES REGRINDING**

We can quickly regrind your shear blades.

The regrinding is performed by tangential grinding machine to preserve the original blades features. After this process all the blades are demagnetized.

# TAVOLA DI PIEGATURA UTENSILI PIEGASCHIACCIA - HEMMING TOOL BENDING CHART

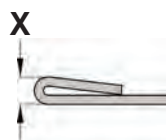
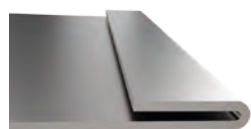

Rm=450 N/mm <sup>2</sup> Rm=65000 PSI	Rm=700 N/mm <sup>2</sup> Rm=100000 PSI
--	---

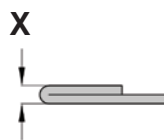

Rm=450 N/mm <sup>2</sup> Rm=65000 PSI	Rm=700 N/mm <sup>2</sup> Rm=100000 PSI
--	---

## SPESORE THICKNESS

mm	inches
0,6	.024
0,8	.031
1,0	.039
1,2	.047
1,5	.059
2,0	.079
2,5	.098
3,0	.118

## POTENZA POWER

X mm	inches	kN/mt	US t/ft	kN/mt	US t/ft
3,0	.118	90	3	150	5
3,0	.118	120	4	200	7
3,5	.137	150	5	250	8
3,5	.137	170	6	300	9
4,6	.181	220	8	380	13
5,5	.216	300	10	500	17
6,5	.255	550	18	900	31
8,0	.314	700	24	1000	34

## POTENZA POWER

X mm	inches	kN/mt	US t/ft	kN/mt	US t/ft
1,2	.047	230	8	350	12
1,6	.062	320	11	500	17
2,0	.078	400	14	600	21
2,4	.094	500	17	800	27
3,0	.118	630	22	950	32
4,0	.157	800	27	1300	44
5,0	.196	900	31	1800	62
6,0	.236	1000	34	2100	72

## PIEGATURA IN ARIA - AIR BENDING

Nella piegatura in aria l'angolo di piega è determinato dalla posizione che la punta dell'utensile superiore raggiunge rispetto ai due spigoli della matrice, posizione variabile a seconda dello spessore, della resistenza e dell'elasticità della lamiera. I vantaggi nell'utilizzo di questa tecnica di piegatura consistono nell'impiego di una minima forza di piegatura e nella possibilità di piegare qualsiasi spessore, compatibilmente al tipo di pressa ed utensili disponibili.

Inoltre gli stessi utensili possono essere utilizzati per differenti tipi di materiale e si possono ottenere angoli inferiori ai 90° e raggi interni di piegatura variabili in proporzione alla larghezza della matrice. Gli svantaggi consistono nel dover utilizzare lamiere con spessore e resistenza costanti per ottenere risultati soddisfacenti.

During the air bending the bending angle is determined by the position reached by the upper tool end position in relation to the die edges. The position changes in connection to thickness, resistance and stretch of material. The advantages in the use of this method are in the use min bending force and in the possibility to bend any thickness being subject to press brake type and tool types. Moreover, the same tools can be used for different material types, for angles lower than 90 degrees and inner radius changeable proportionally to the die slot width. The disadvantages are in the use of metal sheet having exact thickness and resistance in order to get profitable results.



## CONIATURA - COINING

La conatura è un procedimento di piegatura che permette di ottenere pieghe perfettamente a 90° anche in presenza di consistenti differenze di spessore e di resistenza della lamiera. Per contro richiede una forza superiore rispetto alle altre tecniche di piegatura, quantificabile da 5 a 7 volte quella necessaria per la piegatura in aria. Infatti la punta dell'utensile superiore deve coniare il normale raggio di piegatura facendolo combinare con la forma dell'utensile stesso.

Si possono pertanto ottenere pieghe perfette con raggi di curvatura molto piccoli. Gli utensili devono essere calibrati in base allo spessore ed al tipo di lamiera, che non deve comunque superare il limite massimo di mm.2

Forming is a bending method which allows to obtain exact 90 degrees angles even if when thickness and resistance are very different. The method demands max force in comparison to the other bending methods, 5-7 times more than in the air bending. As a matter of fact, the upper tool end has to form the normal bending radius by matching it with the shape of the same tool. This method grants optimal results with very little inner radius. The tools shall be calibrated depending on material thickness and type. Nevertheless the sheet thickness shall not exceed max. 2 mm.



## PIEGATURA A FONDO MATRICE - BENDING ON LOWER TOOL BOTTOM

La piegatura a fondo matrice opera, nella fase iniziale, come per la piegatura in aria, mentre nella fase finale preme sul raggio interno della lamiera piegata determinando l'angolo di piegatura. Praticamente l'angolo di piegatura viene raggiunto agendo sulla forza applicata alla punta dell'utensile superiore nella fase di chiusura. Essendo il raggio di curvatura della lamiera variabile in funzione dello spessore e dell'apertura della matrice, diventa necessario variare la forma degli utensili, anche in considerazione dei diversi ritorni elastici tra i vari materiali. Nell'utilizzo di questa tecnica di piegatura le irregolarità dello spessore e le variazioni della resistenza della lamiera hanno una minima influenza. Pertanto con un corretto accoppiamento degli utensili ed una costante forza di piegatura si può ottenere una sicura ripetibilità dell'angolo di piega. Gli aspetti negativi consistono in un leggero aumento della forza di piegatura (+20% rispetto alla piegatura in aria, a parità di condizioni), nella impossibilità di ottenere angoli inferiori ai 90° e nel utilizzo di lamiere con spessore massimo di mm.5

Die bottom bending is carried out at its first stage in the same way as air bending, while during the final stage the upper tool presses the sheet against the die bottom forming final angle. The bending angle is achieved by acting on the force applied on the upper tool end during the final stage. Since the die radius changes in relation to the thickness and opening of the die, it becomes necessary to change the shape of the tools, also in consideration of the different elastic stretches between the materials. In the use of this bending methods, the differences of sheet thickness and strength are minimal. Therefore, with a correct combination of tool and constant bending force you can get a good repeatability of bent angle. The disadvantages are in a small increasing of the bending force (+20% more than in the air bending method in presence of the same conditions), in the impossibility to get angles lower than 90 degrees and in the use of sheets with max. thickness 5 mm



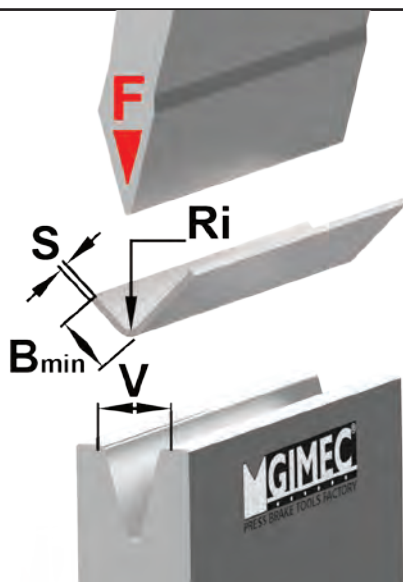

**PIEGATURA IN ARIA AIR BENDING**

<b>F</b>	kN al metro-kN for meter	<b>B</b>	bordo minimo-minimum flange
<b>S</b>	spessore-thickness	<b>Ri</b>	raggio interno-internal radius
<b>V</b>	apertura cava-V opening	<b>R</b>	resistenza-resistance

**AVVERTENZE WARNINGS**

NON SUPERARE IL CARICO MASSIMO AMMESSO DAGLI UTENSILI , IN QUANTO POSSONO DANNEGGIARSI O CAUSARE DANNI FISICI ALL'OPERATORE.

Il carico massimo ammissibile varia in base al tipo di utensili utilizzati.

Calcolare sempre una pressione inferiore rispetto al carico indicato.

EXCEEDING THE MAXIMUM ALLOWABLE TONNAGE FOR THE TOOLING CAN BE VERY DANGEROUS AND MAY RESULT IN TOOLING DAMAGE OR MAY CAUSE BODILY INJURY BY SPLINTERING.

The maximum allowable pressure may vary, depending on the punch and die used.

Always calculate the maximum pressure with the lowest rating of the punch or die.

<b>S</b>	mm	<b>0,6</b>		<b>0,8</b>		<b>1,0</b>		<b>1,2</b>		<b>1,5</b>		<b>2,0</b>	
<b>V</b>	mm	6	8	6	8	6	8	8	10	10	12	12	16
<b>F</b> kN/mt	R 200 N/mm <sup>2</sup>	20	10	30	20	60	40	60	40	70	60	110	80
	R 450 N/mm <sup>2</sup>	40	30	70	50	130	80	130	100	160	130	250	170
	R 700 N/mm <sup>2</sup>	60	40	110	80	190	130	200	150	250	200	390	260
<b>Ri</b>	Ri mm	1,0	1,3	1,0	1,3	1,0	1,3	1,3	1,7	1,7	2,0	2,0	2,7
<b>B</b>	90° B min mm	4,3	5,7	4,3	5,7	4,3	5,7	5,7	7,1	7,1	8,5	8,5	11,4
	60° B min mm	4,9	6,6	4,7	6,5	4,6	6,3	6,2	8,0	7,7	9,5	9,1	12,6
	30° B min mm	7,3	10,2	6,7	9,7	6,2	9,1	8,6	11,5	10,7	13,7	12,3	18,2

<b>S</b>	mm	<b>2,5</b>		<b>3</b>		<b>4</b>		<b>5</b>		<b>6</b>		<b>8</b>	
<b>V</b>	mm	16	20	20	25	32	40	40	50	50	63	63	80
<b>F</b> kN/mt	R 200 N/mm <sup>2</sup>	130	90	140	110	150	110	190	140	210	160	310	220
	R 450 N/mm <sup>2</sup>	290	210	320	240	340	250	420	320	480	360	690	500
	R 700 N/mm <sup>2</sup>	440	330	500	370	530	390	660	490	750	550	1070	780
<b>Ri</b>	Ri mm	2,7	3,3	3,3	4,2	5,3	6,7	6,7	8,3	8,3	10,5	10,5	13,3
<b>B</b>	90° B min mm	11,4	14,2	14,2	17,7	22,7	28,3	28,3	35,4	35,4	44,6	44,6	56,6
	60° B min mm	12,3	15,8	15,4	19,8	25,2	32,2	31,5	40,3	39,6	51,0	49,5	64,6
	30° B min mm	16,8	22,8	21,4	28,8	36,4	48,2	45,5	60,2	57,5	76,7	71,2	96,3

<b>S</b>	mm	<b>10</b>		<b>12</b>		<b>15</b>		<b>20</b>		<b>25</b>		<b>30</b>	
<b>V</b>	mm	80	100	100	125	160	200	200	250	250	320	320	400
<b>F</b> kN/mt	R 200 N/mm <sup>2</sup>	380	280	430	320	390	290	560	420	700	510	770	590
	R 450 N/mm <sup>2</sup>	840	630	960	720	870	660	1260	950	1580	1150	1740	1320
	R 700 N/mm <sup>2</sup>	1310	980	1490	1120	1350	1020	1960	1480	2450	1790	2710	2050
<b>Ri</b>	Ri mm	13,3	16,7	16,7	20,8	26,7	33,3	33,3	41,7	41,7	53,3	53,3	66,7
<b>B</b>	90° B min mm	56,6	70,8	70,8	88,4	113,2	141,5	141,5	176,8	176,8	226,3	226,3	282,9
	60° B min mm	63,0	80,5	79,1	101,0	129,5	164,7	161,0	204,9	201,2	262,7	259,0	329,3
	30° B min mm	90,9	120,4	114,9	151,8	195,3	254,4	240,7	314,5	300,9	404,2	390,6	508,7

**COPYRIGHT © Gimec srl - TUTTI I DIRITTI RISERVATI - ALL RIGHTS RESERVED**

Nessuna parte di questa pubblicazione può essere riprodotta, trasmessa, trascritta, archiviata in un sistema di reperimento o tradotta in qualsiasi forma o con qualsiasi mezzo, senza il consenso scritto della Gimec srl. Inoltre ci riserviamo il diritto di modificare qualsiasi caratteristica tecnica o costruttiva senza l'impegno di comunicazioni preventive.

No part of this publication may be reproduced, transmitted, transcribed, or stored in a retrieval system, or translated into any language or computer language, in any form or by any means, without the prior written permission of Gimec srl.

We also reserve the right to modify any technical or constructive characteristic without any commitment of prior communication.

**Apr 2022 - release 1 - project and graphic realization Roberto Giussani & Alessio Ferrario**

## **Gimec srl**

via della misericordia 37  
Italy 20854 Vedano al Lambro MB  
phone +39.039.492897

[info@gimec.it](mailto:info@gimec.it)



[www.gimec.it](http://www.gimec.it)

**45°37'05.7"N 9°16'00.6"E**  
**Google plus code J798+8P**

